

# Implementation Analysis of Solar Power Generation of 1 Mw Solar on Grid Power Plant

Kamal kishor Mehta<sup>1</sup>, Tushar Agarwal<sup>2</sup>, Mayank Mathur<sup>3</sup>

Department of Electrical & Electronics Engineering  
<sup>1,2,3</sup> Rajasthan Institute of Engineering & Technology Jaipur

**Abstract-** According to the fulfillment of high efficiency and low cost SPV modules, interest in photovoltaic power generation system has increased over the past decade. The modules have maximum operating points corresponding to the environment condition such as intensity of the sunlight coming from sun, the temperature of the modules, cell area, and load. When energy is used as a power source, the output power has to be maximized by improving the efficiency of the power conditioning equipment used and implementing an adaptive power controller that automatically tracks the system to the point of maximum power delivered from the panel under all conditions. It is well known that a module consists of several cells connected in series in order to ensure a useful output voltage level. Assuming that the cells are identical, this level is calculated by summation of each cell voltage. The functioning parameters of the module depend mainly on the irradiation and on the cells temperature, as well as on the semiconductor material characteristics. The SPV modules are held in structure with south facing, because in south facing modules get maximum radiation coming from sun.

**Keywords-** SPV Module, Cell, Solar Inverter, Net meter, Grid.

## I. INTRODUCTION

Grid-connected PV power systems are power systems which are energized by photovoltaic panels which are connected to the utility grid. Grid-connected photovoltaic power systems consist of SPV panels, solar inverters, power conditioning units and grid connection equipment. Unlike Stand-alone photovoltaic power systems these systems seldom have batteries. When conditions are right, the grid-connected system supplies the excess power, beyond consumption by the connected load, to the utility grid. Residential grid-connected photovoltaic power systems which have a capacity less than 8 kilowatts can meet the load of most consumers. They can feed excess power to the grid, which in this case acts as a battery for the system. The feedback is done through a meter to monitor power transferred known as net meter. Photovoltaic wattage may be less than average consumption, in which case the consumer will continue to purchase grid energy, but a lesser amount than previously. If photovoltaic wattage substantially exceeds average consumption, the energy produced by the panels will be much in excess of the demand.

In this case, the excess power can be sell to the grid. Depending on their agreement with their local grid energy company, the consumer only needs to pay the cost of electricity consumed less the value of electricity generated. This will be a negative number if more electricity is generated than consumed. Connection of the photovoltaic power system can be done only through an interconnection agreement between the consumer and the utility company or electricity board. Energy gathered by photovoltaic panels, intended for delivery to a power grid, must be conditioned, or processed for use, by a grid-connected inverter. This inverter installed between the array and the grid, draws energy from each, and may be a large stand- alone unit or may be a collection of small inverters, each physically attached to individual panels. The inverter must monitor grid voltage, waveform, and frequency. One reason for monitoring is if the grid is dead or strays too far out of its nominal specifications, the inverter must not pass along any energy. An inverter is connected or disconnected to the grid according to the safety. And it is known that the inverter waveform occur at the same rate with the grid waveform. The voltage of the inverter is slightly higher than the grid voltage, due to which the energy easily pass from the array.

## II. ARRAY MODELLING AND CHARACTERISTICS

Array which is form to the no of modules that are connected in Series to obtain desired DC voltage and each module consists of approximately 320 Wp. The DC output of modules further convert into the AC through the inverter which is further transfer to the load. Except that each string connected in parallel to deliver more current. The modules used for simulation consists of 38 series connected polycrystalline cells.

## PHOTOVOLATIC MODEL

The electrical equivalent circuit model of cell consists of a current source in parallel with a diode as shown in figure 1.

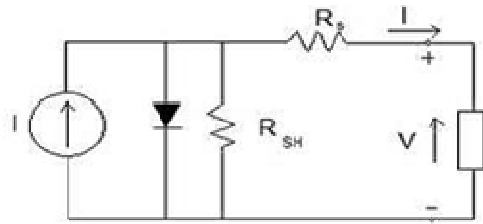

Fig.1: Equivalent Circuit Model of Cell

A MPPT (maximum power point tracking) circuit, which supply the maximum output power of the array. And another is PF (power factor) control unit, which follow the phase of the utility voltage and provides to the inverter a current reference synchronized with the utility voltage. A converter that is consist of a DC to DC converter to increase the voltage, a DC to AC inverter stage, An IT ( isolation transformer ) to ensure that the DC is not inserted into the network, an output filter to block the harmonic currents into the network. The equivalent circuit of the cell, output current is given by

$$I_{PV} = I_{ph} - I_D - I_{sh} \quad (1)$$

Where

$$I_D = I_0 \left( e^{\frac{q(V_{PV} + I_{PV}R_S)}{\eta kT}} - 1 \right) \quad (2)$$

$$I_{sh} = \frac{V_{PV} + I_{PV}R_S}{R_{sh}} \quad (3)$$

Where

- q = Electronic charge
- η = Ideality factor of the diode
- k = Boltzmann constant
- T = Temperature in Kelvin
- I<sub>ph</sub> = Photocurrent
- I<sub>0</sub> = Diode reverse saturation current
- I = Output Current
- V = Output Voltage

As the value of Rsh is very large, it has a negligible effect on the I-V characteristics of cell or array. Thus (1) can be simplified to

$$I_{PV} = I_{ph} - I_0 \left( e^{\frac{q(V_{PV} + I_{PV}R_S)}{\eta kT}} - 1 \right) \quad (4)$$

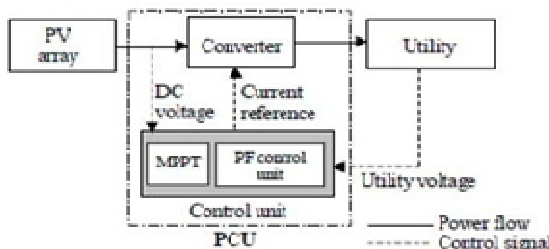

Fig.2: Schematic Diagram of Grid-Connected System

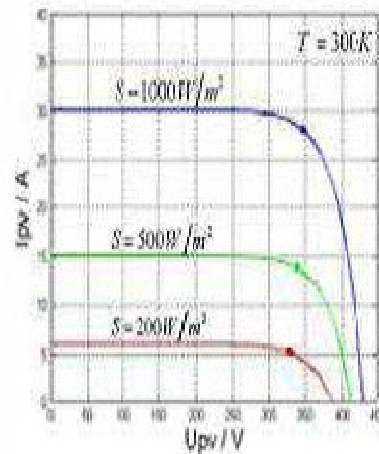

Fig.3: Photovoltaic Module I-V Characteristics

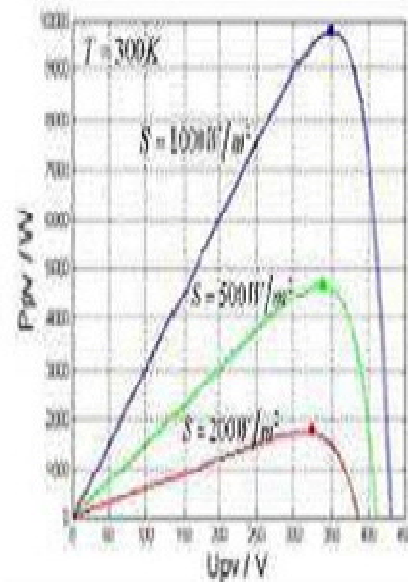

Fig.4: Photovoltaic Module P-V Characteristics

The model is simulated using WAAREE MSX60, 60W WAAREE module. The simulated I-V and P-V characteristics of the WAAREE module at constant temperature and varying the amount of solar radiation reaching a given area are shown Fig.3 respectively. It can be seen from Fig. 3 that the decrease in isolation reduces the current largely but voltage fall is small. Shows that the reduction in the amount of solar radiation reaching a given area reduces the power largely as both voltage and current are decreasing. The effect of temperature on I-V and P-V characteristics of WAAREE module is shown in Fig.4 It can be seen from Fig.4 that the increase in temperature reduces the open circuit voltage largely but rise in current is very small. Fig.4 shows that the increase in temperature reduces the WAAREE output power as the reduction in the voltage is larger than the increase in current due to temperature rise.

### III. DESIGN DETAILS OF THE SYSTEM

The block diagram of the grid connected inverter system is given in Fig.5. The three phase full bridge inverter configuration is the most widely used configuration in three phase systems. The inverter selected is current controlled voltage source inverter that uses IGBT's as the switching element which is operated at a frequency of approximately 1050Hz. Bi-polar PWM technique is used in which switches in each pair are turned ON and OFF simultaneously and output voltage varies between  $-V_{dc}$  and  $+V_{dc}$ , where  $V_{dc}$  is the input voltage of inverter which is considered as battery as shown in block diagram.

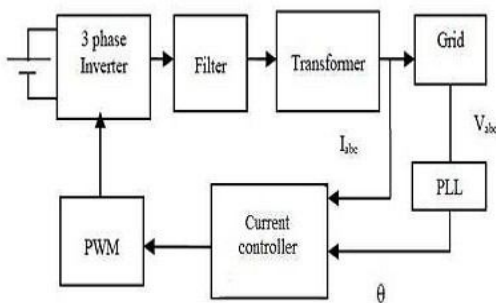

Fig 5: Block diagram of the system

The output of each leg depends only on input voltage and switch status and is independent of load current. Transformer steps up the inverter output voltage. Besides this, it provides isolation and prevents injection of dc current in to the grid Generally delta-star transformer configuration is used in grid connected system because the third harmonic will get circulated in delta and does not enter in the grid.

#### L Filter

Output voltage wave is synchronized with the grid voltage. So the PWM inverter will inject ripple current in to the grid. The output L filter is connected to remove high switching frequency components from output current of inverter. The filter is designed taking into account the following parameters for the grid and inverter. The value of L is design based on current ripple. Smaller ripple results in lower switching and conduction losses.

#### Phase lock loop(PLL)

Grid synchronizations plays important role for grid connected systems. It synchronizes the output frequency and phase of grid voltage with grid current using different transformation. Different methods to extract phase angle have been developed and presented in many papers up to now [8]

PLL techniques causes one signal to track another one. It keeps an output signal synchronized with a reference input signal in frequency and phase. In three phase grid connected system PLL can be implemented using the current control technique.

SPECIFICATIONS: make WAAREE WS-230, Max power (Pmax) 236.5W, Maximum power voltage (Vmp) 26.8V, Maximum power current (Imp) 7.33A, Short Circuit Current (Isc) 8.21A, Open Circuit Voltage (Voc) 35.5V, Maximum System Voltage 1000V. Total Number of panel use- 12288.

Total Panels are divided into 4 Section, each section are of 240KW: 4000 panels are in a sections. All the four cable from four different sections are connected to LT panel (Low Tension Panel) and From LT Panel Cable is connected to transformer.

From transformer cable is connected to HT Panel (High Tension Panel) then from HT panel Cable is connected to 33KV grid via metering panel.

Specifications of Transformer: Total 1 No., 1250 KVA, 415V/33KV Specifications of Inverter: Total 4 Nos., 240KW each, make - Sunny Central, Model-SC250M,

### IV. MATLAB/SIMULINK MODELLING AND SIMULATION RESULTS

The Mat lab/Simulink model of PV module connected to grid with PLL controlled inverter.

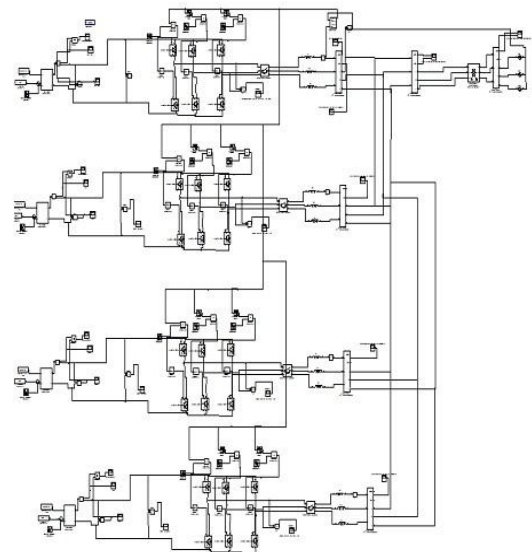

Fig.6: Mat lab/Simulink model of inverter connected to the grid

The below wave form shows the 430v of cell voltage

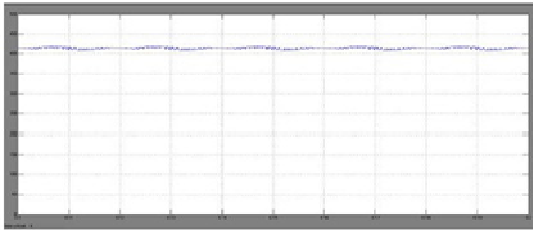

Fig.7: Simulated output wave form of Cell voltage

The below wave form shows the current generated from the Cell

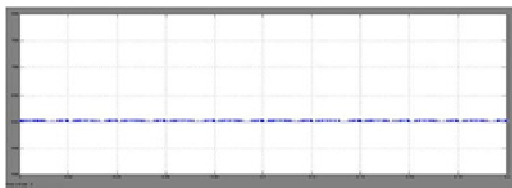

Fig.8: Simulated output waveform of cell voltage

The below wave form shows the 2.5kw of power

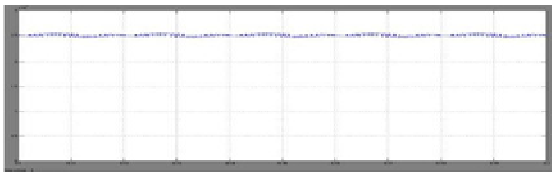

Fig.9: Simulated output waveform of cell power

## V. CONCLUSION

The design of the system is carried out for feeding 1500MVA power to the grid The Inverter is controlled in order to feed active power to the grid, using current controller. Phase locked loop (PLL) is used to lock grid frequency and phase. The phase detection part of PLL is properly used in the three phase system. The inverter output current shows that the Total harmonic distortion (THD) is within limits and the controlled injected current generates three phase balance current which controls power at the output of the transformer. To simulate the actual grid connected system, the PV model and inverter has been included.

## REFERENCES

- [1] Solanki CS. WAAREE Photovoltaic's: Fundamentals, Technologies and Applications. PHI Learning Private Limited, New Delhi, 2009.
- [2] Alajmi B, Ahmed K, Finney S, Williams B. Fuzzy Logic Controlled Approach of a Modified Hill Climbing

Method for Maximum Power Point in Micro grid Stand-alone Photovoltaic System. IEEE Transactions on Power Electronics 2011; 26(4): 1022-1030

- [3] Al-Zamil AM, Torrey DA.. A Passive Series, Active Shunt Filter for High Power Applications. IEEE Transactions on Power Electronics 2001; 16(1): 101-109.
- [4] Takun P, Kaitwanidvilai S, Jettanasen C. Maximum Power Point Tracking using Fuzzy Logic Control for Photovoltaic Systems. International conference of engineers and computer scientists (IMECS) 2011; II: 986-990.
- [5] Zue AO, Chandra A. Grid Connected Photovoltaic Interface with VAR Compensation and Active Filtering Functions. International Conference on Power Electronics, Drives and Energy Systems, PEDES'06, 2006