

Greenhouse Parameter Monitoring & Controlling Using GSM

Pallavi V. Yadav¹, Komal L. Sonwane², Nishigandha B. Magar³, Aishwarya B. Gund⁴, Prof. Yogesh S. Ghodake⁵

Department of Electronics And Telecommunication Engineering
1,2,3,4,5 Karmayogi Engineering College, shelve, Pandharpur.

Abstract-Greenhouse monitoring is a needed one for Variable climate changes. GSM technologies have been rapidly developing wireless technology during few years. Starting from industrial controls and telecommunications, it is now being applied in environmental monitoring and agriculture.

The existing system has the ability to yet lack the ability to control indoor humidity and other parameter. This project is used to measure various parameters like temperature, humidity, and light and soil moisture. Values of these sensors are displayed on a LCD. These parameters are sensed by sensors and sensor output is applied and given to ADC. Microcontroller controls these parameters and keeps them at some predefined values using relay interface. At the same time these current values of all parameters are sent through SMS using a GSM modem.

Keywords-Green House, Keil Software, GSM, Wireless sensor network, Microcontroller.

I. INTRODUCTION

We live in a world where everything can be controlled and monitored automatically. But there are still few important fields where automation is needed like agriculture. Green house forms and important part of agriculture which is use to control environmental conditions for optimum production. Automation is the process for green house controlled parameters automatically by replacing the human efforts.

In this system user communicates with the centralized unit using SMS. This unit communicates with the system through SMS which will received by the GSM with the help of SIM card. The GSM send its data to microcontroller which is also continuously receives the data from sensors. After this data is displayed on the LCD. After receiving the activation command from the subscriber first it checks all conditioned gives detailed feedback to the user. To control these parameters of greenhouse different relays are used. Relay is an electrical switch that open and closed under the control of another electrical circuit. Relay is able to control output circuit of higher power than input circuit.

II. SYSTEM DESIGN & IMPLEMENTATION

The hardware unit of the prototype of the system is represented by the block diagram above. It contains an 89S52 microcontroller as the main processing unit and it gets inputs from the temperature sensor (LM35), Light sensor (LDR),

Humidity sensor (DHT11), Moisture sensor (VH400). From the data obtained from the sensors the program controls the actuator components such

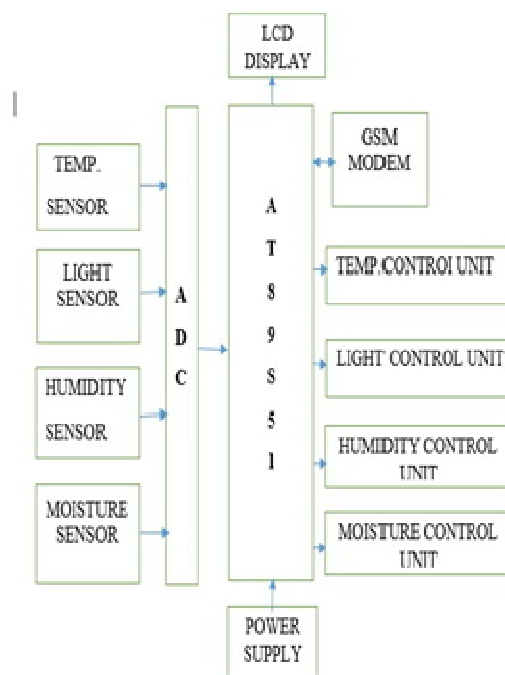

Figure 1.0 block diagram of Greenhouse parameter monitoring and controlling by using GSM

as fan, sprinkler, bulb and humidity control unit to achieve the system requirements. It also uses a GSM module which sends information from of SMS to the user from which the data obtained from the sensors and the data obtained from the user. The system operates according to the flow chart show. The temperature monitor and control system consists of a LM35 temperature sensor. Initially a temperature point is set. The temperature sensor sense the change in input

temperature. After signal conditioning this analog signal is given to the microcontroller. The microcontroller converts it to digital format using on chip ADC. If the temperature sensed is below the low threshold value, the controller unit will start the heater. Once it reaches the set limit it will switch off the heater. If the temperature sensed is above the set limit, it will start the fan to bring the temperature down. Once it reaches below a set point, it will switch of the fan. In this way, temperature is controlled. Similarly, an intensity of light can be controlled. Initially intensity point is set. Light dependent resistor senses the change in input intensity of light. If the intensity of light sensed is below the low limit set, the controller unit will switch on bulb. In this way, intensity of light is controlled. Humidity can be control by using a humidity sensor. Initially humidity is set. Humidity sensor senses the change in humidity. If the humidity sensed is below the low limit set, the controller unit will turn on the dehumidifier. Once it reaches the set limit it will switch on the humidifier. In this way, humidity is controlled. After it senses intensity of temperature, light, humidity and moisture it gives digital display at the output on LCD.

III. WORKING

The system above consist of four input(temperature, humidity, Light and soil moisture sensor) are four outputs (fan, humidity control unit, bulb and sprinkler). Microcontroller is the main brain for this system because it controls the overall system in the green house. Temperature sensor is used to detect the temperature in the green house. When temperature sensor detects the high temperature, microcontroller will send the signal to fan to stable the greenhouse condition. Then, when light sensor detects no light, microcontroller will send the signal to bulb and bulb will be ON automatically. Water pump is used to supply water to the sprinkler and make sure the sprinkler watered the plants in the greenhouse.

As we see in figure, the microcontroller controls circuit that will be connected to the moisture sensor, humidity sensor, Light sensor and temperature sensor. The microcontroller receives the value from sensors and analysis and then compares it with the threshold value stored in microcontroller memory, based on this value the microcontroller takes the appropriate procedures and also controls the output device based on these values; the microcontroller sends the report by the GSM modem to the farmer's phone.

As soon as the change of temperature or humidity absence of air for instance has been detected, GSM modem sends SMS on a number provided in the GSM code.

Through this section user can manage greenhouse hardware or manage the SMS service.

Initially a temperature point is set. The temperature sensor sense the change in inputtemperature. After signal conditioning, this analog signal is given to the microcontroller. The microcontroller converts it to digital format using on chip value. If the temperature sensed is below the low threshold value, the controller unit will start the heater. Once it reaches the set limit it will switch off the heater. If the temperature sensed is above the set limit, it will start the fan to bring the temperature down. Once it reaches below a set point, it will switch of the fan. In this way, temperature is controlled. Similarly, an intensity of light can be controlled. Initially intensity point is set. Light dependent resistor senses the change in input intensity of light. If the intensity of light sensed is below the low limit set, the controller unit will switch on bulb. In this way, intensity of light is controlled. Humidity can be control by using a humidity sensor. Initially humidity is set. Humidity sensor senses the change in humidity. If the humidity sensed is below the low limit set, the controller unit will turn on the dehumidifier. Once it reaches the set limit it will switch on the humidifier. In this way, humidity is controlled. After it senses intensity of temperature, light, humidity and moisture it gives digital display at the output on LCD.

MICROCONTROLLER

A microcontroller is a small computer used in one IC containing a processor core, memory and programmable input output peripherals. A microcontroller is used and designed for embeddedapplications.

RELAY

A relay is an electrically operated switch. A relay used an electromagnet to operate a switch mechanically. Relays are used for controlling a circuit by a low power signal.

ADC

It is a system that converts an analog signal into digital form. It is a 28 pin IC.

GSM Module:

A GSM modem is a wireless modem that works with a GSM wireless network. A wireless modem behaves like a dial-up modem.

Temperature Sensor:

LM35 IC is used to sensing the temperature. It is an integrated circuit sensor that can used to determine temperature with an electrical output proportional to the temperature.

Humidity Sensor:

It is used for sensing the humidity. Relative humidity is a measure in percentage, at a given temperature the vapors in the air compare to the total amount of vapors.

Light Sensor:

Light Dependent Resistor is used to vary according to the amount of light falling on its surface. LDR decreases as intensity of light falling on it increases.

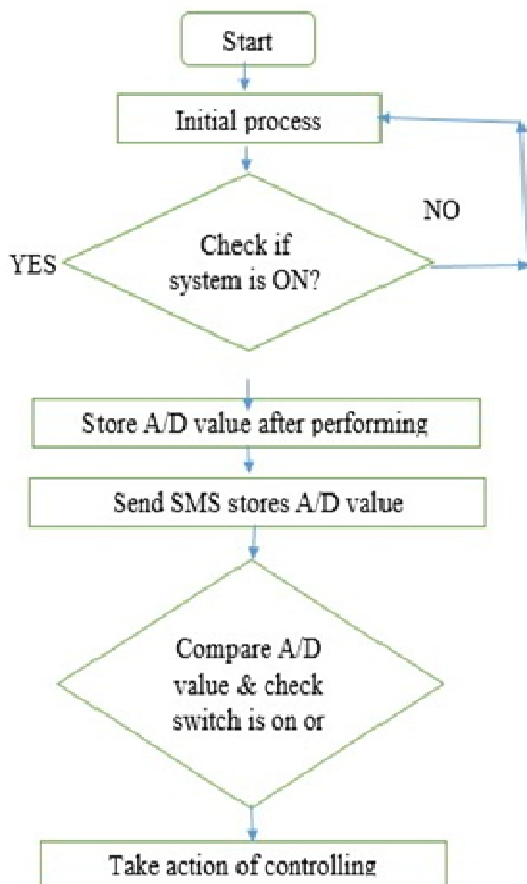

RELAY

A relay is an electrically operated switch. A relay used an electromagnet to operate a switch mechanically. Relays are used for controlling a circuit by a low power signal.

Moisture Sensor:

In green house moisture sensor is used to determine the level of water in soil.

IV. EXISTING SYSTEM

The existing set-ups primarily are:

Manual Set-Up:

This set-up involves visual inspection of the plant growth, manual irrigation of plants, turning ON and OFF the temperature controllers, manual spraying of the fertilizers and pesticides. It is time consuming and hence less accurate and unreliable. Partially Automated Set-Up:

This set-up is a combination of manual supervision and partial automation and is similar to manual set-up in most respects but it reduces the lab our involved in terms of irrigating the set-up.

Fully Automated:

This is a sophisticated set-up which is well equipped to reach to most of the climatic changes occurring inside the greenhouse.

Proposed System:

From as the current problem section, it can be seen that the existing systems are insufficient to handle the problems of the greenhouse monitoring and controlling. To solve these problems we propose the monitoring and control of greenhouse using GSM. It mainly consist of the sensing part, controlling part, monitoring part and a message sending and receiving part. In the monitoring part the sensors included are temperature sensor, humidity sensor, light sensor, soil moisture sensor.

These sensors will sense the various parameters of the environment and the values will be displayed on an LCD display.

V.CONCLUSION

We built an automated greenhouse model using GSM. The system supervise and control the irrigation, light, temperatures and humidity levels for optimum plant growth. This automating technology saves time and money by

eliminating the need for service personnel to visit each site for inspection. The system is modified to alert farmers regarding the parameter changes in the greenhouse so that early precaution steps can be taken.

REFERENCES

- [1] International Journal of Scientific & Engineering Research, Volume 3, Issue 2, February-2012 ISSN 2229-5518 IJSER @ 2012 <http://www.ijser.org> “ Wireless Monitoring of the Green House System Using Embedded Control.”
- [2] “Development of data acquisition and greenhouse control System based on GSM ” International Journal of Engineering, science and technology Vol.3,No. 8,2011,pp. 297-306 International Journal of Engineering, science and technology.
- [3] ” Application of wireless sensor networks for greenhouse parameter control in precision agriculture” (IJWMN) Vol. 3/ No.1,February2011DOI10.5121/ijwmn.2011.3113