

# Iot Based Smart Medical Adherence System

Mrs. Sharmila Agnal<sup>1</sup>, Atmaja Raman<sup>2</sup>, Prathibha Warriar<sup>3</sup>, Munukoti Mrithika<sup>4</sup>

<sup>1</sup>Assistant Professor, Department of Computer Science Engineering

<sup>2,3,4</sup>Department of Computer Science Engineering

<sup>1,2,3,4</sup>SRM Institute of Science and Technology

**Abstract-** One of the many applications of Internet of Things (IoT) is in the field of healthcare, which is rapidly developing. This paper focuses on the ease of medical adherence with the help of a Smart Pill Bottle. This is done using IR sensors, LiPo battery, WiFi chip and other components that are integrated with a GSM module to send alerts and notifications to the user when required. ESP8266 WiFi chip and Arduino IDE have been used. The smart pill bottle aims to improve adherence to medication.

**Keywords-** Adherence, IR Sensor, GSM module, Alert system, RTC.

## I. INTRODUCTION

Applications of technology in the healthcare sector is increasingly and continuously undergoing innovations in order to improve accuracy and efficiency. Medical adherence is one of the major issues and improper consumption can lead to health issues. Medication adherence rate was found to be unsatisfactory in India. The main challenging factors affecting medication adherence were forgetfulness, being busy and medicines inaccessibility [1]. In the United States, not adhering to medicines cost several hundreds of billions of dollars and result in more than 100,000 deaths per year [2]. This project is one example of technological innovation in healthcare that aims to improve medical adherence; the smart pill bottle. The incorporation of internet of things enable automation of activity tracking and also provides the ability to sense the surrounding. Electronic medication monitors are can be used for tracking medication taking patterns and are very precise [3]. The pill bottle can be used to monitor the number of times pills taken, the times of a day when they were taken and the level of pills left in the bottle. It sends out frequent reminders and notifies when a dosage has been missed or excess has been consumed. It also notifies when the bottle requires a refill. It automatically keeps track when the bottle is opened and marks a dose that has been taken thereby making consumption of medicines on a day to day basis much easier. For this project, an IR sensor, a small LiPo battery, an ESP8266 WiFi chip, GSM module and other basic components are needed. All of these components are placed within the bottle cap. The data can be monitored by the patient or their guardian to keep track of their health status. It aims to make medical adherence easy and eliminate causes such as

forgetfulness and carelessness which leads to improper medicine intake. This simple model also aims to make medical adherence easy for the elderly who find difficulty handling advanced technology such as smartphones and apps.

## II. RELATED WORK

This section gives a brief overview on the previous works done to improve medical adherence. A pill box created from cardboard has been implemented with Arduino. It has many sub boxes that act as compartments for various pills [4]. Instead of a pill bottle, medicine bags have also been made to be dispensed with the help of a stepper motor. The system consists of a medicine box fitted with buttons for various functions. A prototype for a Bluetooth bracelet model has also been implemented [5]. A proximity sensing-based approach with the help of RFID (Radio-frequency indicator) technology has been taken up. It makes use of RFID tags or smart labels. It contains specific prescription details of the user, filled by the pharmacist in an XML database. It also gives vocal reminders to the patient to take their pills or place the bottle on the stand provided for it. A touch-sensitive picture frame also serves the same purpose [8]. In addition to the proximity-sensor approach, other approaches that have been studied include wireless sensor networks (WSNs), visual/camera approach and hybrid approaches that are a combination of the previously mentioned ones [6]. Apart from these, various studies have been undertaken to understand medical adherence and ways of improving it through various interventions [7].

## III. PROPOSED METHODOLOGY

The proposed system aims to improve the ease of medical adherence, especially for elderly people and the working population, by implementing technologies which are easy to use by laymen and require less effort to access.

### A. SYSTEM ARCHITECTURE

The proposed system consists of three modules namely

- Real Time Clock (RTC) module.
- Global System for mobile communication (GSM) module.

- Alert System.

The pill bottle consists of a **real-time clock (RTC)** which is a computer clock that keeps track of the current time and processes the activities and accordingly notes the time of intake of pills. The **GSM module** will be used to send notification message to the user or family members in case a dosage is missed. When it is time to take the for the consumption of the user’s daily medicine, the **buzzer** will beep and **LED** will flicker in order to notify the person to take the medication.



Fig. 1. Block diagram of proposed model

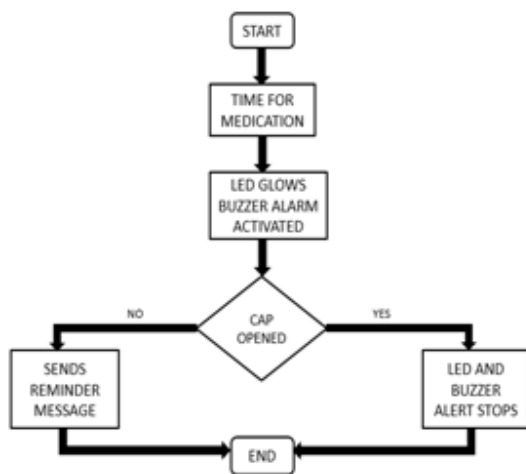

Fig. 2. Data flow diagram

*a. GSM SYSTEM*

GSM is a globally used mobile communication system. GSM is an open and digital cellular technology used for transmitting mobile data services and operates at a frequency of about 850MHz, 900MHz, 1800MHz and 1900MHz frequency bands. GSM was developed using a time

multiple division access. TDMA is based on assigning different time slots to each user with same frequency. It can easily adapt to data transmission and communication which can carry 64kbps to 120Mbps of data.

Fig. 3. GSM module

Here the GSM module is connected to the pill bottle and alerts the user to refill when empty, it also alerts when the user has missed the dosage. GSM module is connected to the other modules within the pill bottle which in return passes necessary information to the user.

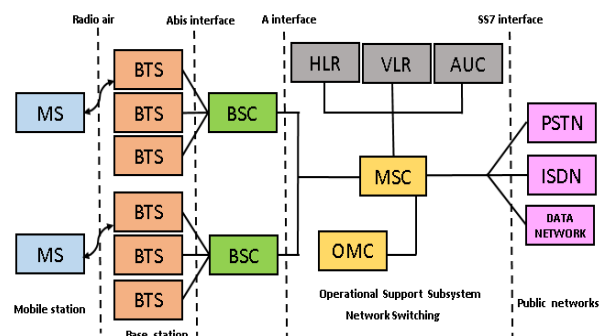

Fig. 4. GSM module

*b. REAL TIME CLOCK SYSTEM*

Real time clocks/calendar provides seconds, minutes, hours, day, date, month and year qualified data. They are available as a integrated circuit; it supervises timing like a clock and also operates date like a calendar does. The main advantage of RTC is that it has battery backup which keeps the clock/calendar running even if there is a less power or power failure. We can find RTCs applications embedded in systems or mobiles or computer’s motherboard.

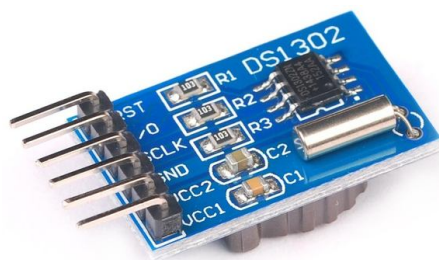

Fig. 5. RTC Module

*c. ALERT SYSTEM*

A magnetic buzzer is based on a electromagnetic principle and is very similar to the piezo buzzer. It makes a buzzing noise and is used for signalling purposes. The most

commonly used type of buzzer is the piezo buzzer. It works on the principle which is the reverse of piezoelectric effect. It comprises of piezo crystals between two conductors. When potential is given to these crystals, they push on one of the conductors and then another. The push and pull actions results in production of sound waves. A magnetic buzzer is based on the electromagnetic principle and is very similar to the piezo buzzer. A metal diaphragm is pulled when power is given, and springs back when power is not present. This causes the production of sound.



Fig. 6. Piezo Buzzer

LED stands for Light Emitting Diode. It is a small, active semiconductor, p-n junction diode which works on the principle of electroluminescence. When a suitable voltage is applied to the two leads of the diode, the free electrons combine with electron holes and release energy in the form of photons. Hence when the diode is activated, it emits light. The color of the LED light depends on the energy band gap of the semiconductor.



Fig. 7. Light Emitting Diode

**B. COMPONENTS**

**• ESP8266 Wi-Fi Microchip**

The ESP8266 is a low budget and self contained Wi-Fi SOC (System on a Chip) integrated with full TCP/IP stack. It can give any microcontroller access to the Wi-Fi network and is capable of either hosting an application or offloading the networking functions from another application processor.

**• GSM**

The GSM module is used to send a text message when it is time for the user’s consumption of their daily medication. It also sends an alert for refill to the user.

**• Real Time Clock Module**

A real-time clock (RTC) is a battery based clock which is placed in the cap of the pill bottle. It tracks the current time.

**• IR Sensor**

An infrared sensor is a sensor with which we can detect or measure an infrared radiation or change in the radiation from a source. It is used to detect the level of pills in the bottle.

**• Buzzer and LED**

An LED and a BUZZER is used to alert the user when it is time to take medication by giving light and sound indication.

**IV. INFRARED SENSOR**

In this model, an infrared (IR) sensor has been used to detect the level of pills inside the bottle. The infrared radiation is the portion of electromagnetic spectrum that lies approximately between 0.75µm and 1000µm. These waves are not visible to the human eyes. The entire infrared region can be divided into near infrared, mid infrared and far infrared regions. Different types of IR sensors work in different regions of the IR spectrum. But all the IR sensors work in accordance with three laws [9].

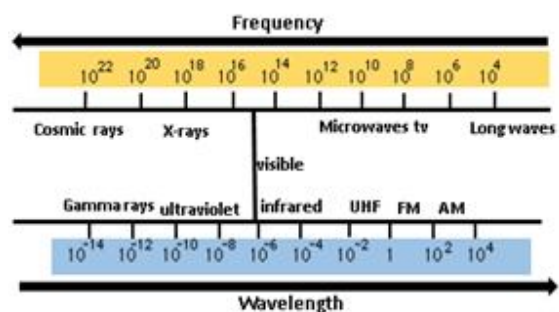

Fig. 8. Infrared ray range

*Planck's radiation law:* This law explains the spectral-energy distribution of the radiation emitted by a blackbody in thermal equilibrium at a given temperature T.

$$\Delta P\lambda = (8\pi hc)/\lambda^5 [ehc/(K\lambda T) - 1] \Delta\lambda \quad (1)$$

$\Delta P\lambda$  - energy density within a given small wavelength interval  $\Delta\lambda$   
 $h$  - Planck constant  
 $c$  - speed of light

*Stefan-Boltzmann law:* This law states that the total radiant heat energy that is emitted from a blackbody is corresponding to the fourth intensity of its total temperature.

$$J = \sigma T^4 \quad (2)$$

J - Energy radiated per unit area of a blackbody per unit time  
 $\sigma$  - Stefan-Boltzmann constant  
 T - Absolute temperature

*Wien's displacement law:* This law states that the wavelength carrying the maximum energy is a blackbody is corresponding to the fourth intensity of its total temperature.

$$\lambda_{\max} \times T = b \quad (3)$$

$\lambda_{\max}$  - Wavelength of maximum intensity  
 T - Temperature of the blackbody  
 b - Wien's displacement constant

A typical system to detect the infrared radiation has the following components and its structure :

Fig. 9. IR Structure and components

## V. ANALYSIS AND RESULTS

These days everyone is in a hurry, people tend to forget the smallest of details in such a fast paced life. The most frequent thing people forget are medicines, and this might affect the person's health and in a long run might even result in the death of a person. This equipment mainly helps the elderly, the people who fail to remember and also the people with a busy schedule, in reminding them with their daily medication of pills. It reminds them that it is time for their intake of medicines with an old fashioned alarm system, but with a more advanced RTC model, it notifies them in case they miss their dosage and sends a message to the user and user's family member or guardian. The GSM module also sends an alert to the user to refill when necessary via text. Keeping in mind that it is difficult for the elderly to

comprehend too much of technology, this simple pill bottle will help them keep track of their medication.

## VI. CONCLUSION

This design proposes a smart pill bottle which is a daily medication reminder. This design, is relatively simple to use for a user who requires a machine with both storage of the pill and the continuous medical adherence function. With the Real Time Clock Module, ESP8266 Wi-Fi Microchip and IR Sensor even if the user is not nearby, the bottle will send a reminder to the user by means of the GSM module.

## VII. FUTURE WORKS

The future scope of this project is pretty vast and has a lot of room for more advanced technology to be included. Capacitive sensors can be used along with the current model in order to get a count of how many pills have been taken from the bottle and of what weight (in grams). These details can be displayed on top of the bottle cap with the help of an LCD display. Fingerprint sensors can also be included in order to make the pill bottle accessible by only by the person taking the medication, in order to prevent children and other people from consuming the medicines or giving the wrong medication.

## REFERENCES

- [1] Medi RK, Mateti UV, Kanduri KR, Konda SS. "Medication adherence and determinants of non-adherence among south Indian diabetes patients," *J Soc Health Diabetes*, 2015, pp. 3:48-51.
- [2] M. Viswanathan, et al., "Interventions to Improve Adherence to Self administered Medications for Chronic Diseases in the United States: A Systematic Review," *Annals of Internal Medicine*, Dec. 2012, vol. 157, no. 11, pp.785-795.
- [3] L. Osterberg, and T. Blaschke, "Adherence to medication," *New England Journal of Medicine*, Aug. 2005, vol. 353, no. 5, pp. 487-497.
- [4] A. Jabeena, A. K. Sahu, R. Roy and N. S. Basha, "Automatic pill reminder for easy supervision," *2017 International Conference on Intelligent Sustainable Systems (ICISS)*, Palladam, 2017, pp. 630-637.
- [5] Y. Bai and T. Kuo, "Medication adherence by using a hybrid automatic reminder machine," *2016 IEEE International Conference on Consumer Electronics (ICCE)*, Las Vegas, NV, 2016, pp. 573-574.
- [6] M. Aldeer and R. P. Martin, "Medication adherence monitoring using modern technology," *2017 IEEE 8th Annual Ubiquitous Computing, Electronics and Mobile*

- Communication Conference (UEMCON)*, New York, NY, 2017, pp. 491-497.
- [7] Haynes RB, Ackloo E, Sahota N, McDonald HP, Yao X. "Interventions for enhancing medication adherence," *Cochrane Database of Systematic Reviews*, 2008, Issue 2. Art. No.: CD000011.
- [8] Anand Agarawala, Saul Greenberg and Geoffrey Ho. "The context-aware pill bottle and medication monitor," Technical Report 2004-752-17, *Department of Computer Science, University of Calgary*, 2004.
- [9] Liu, Linda L., Park, Denise C. *Aging and Medical Adherence: The Use of Automatic Processes to Achieve Effortful Things*. By Psychology and Aging, June 2004, Vol 19(2), pp. 318-325
- [10] Jain, P. (n.d.). *IR Sensors / Types of IR Sensors & Working*. [online] Engineersgarage.com. Available at: <https://www.engineersgarage.com/articles/infrared-sensors> [Accessed 28 Sep. 2018].