

# A review of Effective and Secure Scheme for Video Multicasting Using Real Time Transport Protocol (RTP)

Jitu G. Patil<sup>1</sup>, Prof. Pyush singh<sup>2</sup>

<sup>1,2</sup>Department of Computer Science Engineering

<sup>1,2</sup>RKDF Institute of Science and Technology, Hoshangabad Road, Bhopal, Madhya Pradesh.

**Abstract-** Real-time live video or saved video is the emerging part of the multimedia network in real-time. In streaming technology, video files do not need to be fully downloaded but when you are accepting and decoding video file content. Compressed Video Data and Communication Protocol Design These are two ways to send video through the Internet. One-step is to protect the result of a low-bit encoder and UDP usage bit stream. Another way to design a new transport protocol is to use the Video Encoding Algorithm. Security plays an important role in the implementation of streaming. In this paper, we will present a review of efficient solution for encryption in Video Sequence using the AES-CFB client-server unreliable network. Prototype systems provide a safer way and more secure transmission through the internet with assurance while using standard RTP.

**Keywords-** Video streaming, Advanced Encryption Standard (AES), Real Time-Transport Protocol (RTP), User Datagram Protocol (UDP), Secure Real Time-Transport Protocol (RTP).

## I. INTRODUCTION

Streaming data for different users has been becoming ever more popular in recent times and protecting, the data transmitted from danger to every possible security has become one of the main concerns for both end users and data providers. This review describes a method to protect the stream data from possible security attacks and a design video of the secure system architecture for multimedia video current streams on the receiver of a stream at a time to consider the state of the art for streaming today. The key advantage of the projected design is the ability to have a protected communication situation for real-time data. Real-Time video Streaming is a process of playing streaming audio and video files without downloaded. Video streaming refers to [1] real-time transmission of stored video or live video. There is a download mode and second streaming mode of two types of video saved through the available internet. In download, mode user has permission to download the full video file and then runs back the video file. In steaming mode user does not have

to download video and see file without full download, but the video file is just being played on receipt of a part. Streaming Video Bandwidth is Real-time in nature, delay and decrease in packet demand Audio compression algorithm and video data stored with video streaming. Video compression and raw video collected and stored in storage devices. Then a client requesting a client compresses the storage device to specific client audio and video data. When it starts sending audio and video streams on the Internet using the compressed bit stream of Network Transport Protocol packet on the Internet the audio and video streams start to send. For those packets which are successfully distributed on receiver, they all are pass through the more transport layer and then decode audio layer of the audio or video. Quality streaming audio and video data transmission is developed for the Internet to improve continuous media distribution services and media synchronization.

Video Compression technology (H64) is a business standard for video compression in which digital video format conversion takes place of video. Which it is stored or when it has a small amount of power to make it video compression for digital television video, mobile TV, video conferencing and as an important technology for applications that takes the Internet to transmit video streaming. Video compression to adapt to various producers (e.g. encoder, decoder and storage media) products, including possible inter-operator in an encoder and a compressed format video, in other hand decoder transmits the video to uncompressed format.

Real Time Transport Protocol [3] used to provide support for real-time information such as video and audio streams on internet protocol based protocol. Real-Time Features for RTP data-to-deliver delivery services. Services offered by RTP reconstruction, detection, security and identification made by the materials. RTP does not provide all the functionality required for information and as a result, like a user datagram protocol (UDP) applications, a transfer protocol generally takes it to the top. RTP does not deal with a real time quality of reservation and service (QOS) not guaranteed.

It actually supports lower level control on switches and router assets. The companion of the RTP, RTP Control Protocol (RTCP) [5], which is to send feedback to the data flow, quality control and the recipients of the client-server system. Message sender, which is the five RTCP report, receiver report, the source of the message and the application send specific message. Secure real-time protocol [4] is a real-time transport protocol (RTP) which has authentication instead of a profile of a confidential message and competition for RTCP (real-time transport control protocol) with RTP traffic. SRTP make available a framework intended for RTP and RTCP authentication and the message encryption bar. SRTP can achieve higher output and lower packet expansion. SRTP from RTP is designed to work with stack implementation and a specific key for a specific price, independent of management and multimedia internet Keyig in SRTP. There are some rewards in contrast to the RTP security alternative H.264 in media streaming. Information listed under for security and safety of features, SRTP provides increased security achieved by

- Confidentiality for RTP as well as for RTCP with the help of encryption of the particular payloads.
- Integrity for the entire RTP and RTCP packets combined with replay protection.
- The opportunity to restore the session solutions periodically, which restrict the quantity of cipher data formed by a fixed key, flexible for an supporter to cryptanalysis.
- An extensible structure that allow advancement with new cryptographic algorithms.
- A protected session key origin with a pseudo-random task at both ends.
- The practice of salting keys to guard against precomputation attacks.
- Security aimed at unicast and multicast RTP practical uses.

V	P	X	C C	M	PT	Sequence Number
Time Stamp						
Synchronization Source SSRC						
Content Source CSRC						
Payload						
RTP Extension (optional)						
Authentication Tag						

Figure 1. An RTP packet for MPEG-4

## II. SCHEME FOR VIDEO MULTICASTING USING REAL TIME TRANSPORT PROTOCOL (RTP)

In implementation of secure video streaming audio-video, data is compressed and data sent to air and SRTP packet layer is recovering compressed data. The time and synchronization of information packet provides SRTP and number of arrangements as well. The SRTP packet stream sent to the UDP layer and the IP layer. As a result, the IP packet goes across the internet. On the contrary, the compressed data processed before the streams on the media receiver. Control for SRTCP is transferring RTSP packets for broadcast across UDP packets on internet. Fig. 2 shows the Video Streaming across the Internet. This system capture the video on or after camera or stored audio/ video files and have to encode the video by using H.264 then that video will be detached with packet by packet before it will be directed as streams over RTP protocol and that will be acknowledged in alternative side of RTP media player.

### 1. Secure Video Streaming Architecture

In the key achievements of the revolution that enabled for User Datagram Protocol (UDP) and Internet streaming, a new encoding approach is precise lesser packet implemented by compressing the Internet Protocol. Internet viewer to transmit data from client player or host server (HTTP and TCP) more strongly than the UDP streaming media at the end of the previous protocol. This kind of real-time streaming protocol (RSTP) is more efficient [6] and more recent protocols, such as data transmission,

RTSP server RTSP client files from the first operation, RTSP option, RTSP setup, RTSP PLAY, RTSP DESCRIBE and RTSP Teardown to use its end-user remote control. To implement the approach of Table 1 RTP-RTSP and RTP Client-Server Connection, we are using simulation tools available to customer for packet cached from the server. The RTSP client and server operations are described in figure 5 and the transport layer of UDP in the compressed audio and video RTP / IP layer then sends on the Internet. SRTP packet protocol to transmit audio and video packets used for transport layer transactions.

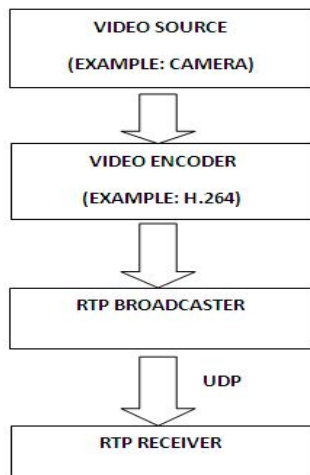

Figure 2. shows video streaming across the Internet.

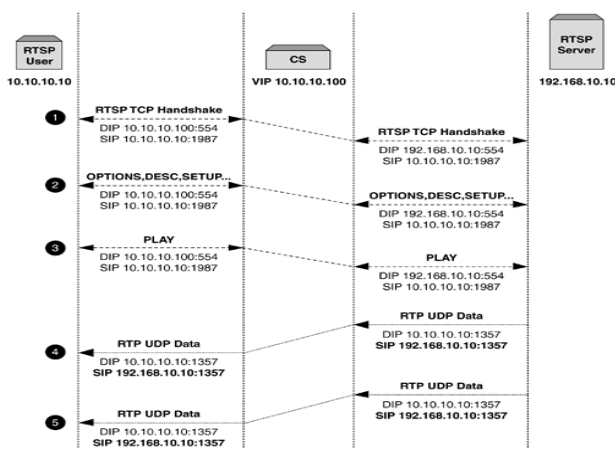

Figure 3. RTSP client and server connection

**2. Packet transmission scheme**

MPEG-4 video data packetization takes place with a number of schemes for SRTP. If there is a policy on addressing SRTP media packaging, then it will probably need to have a variety of media, audio, video and SRTP associated with a variety of plans. You can reach the fastest time of the presentation time stamp unit, in order of serial number in the SRTP packet is similar to the broadcast. Logical payload or physically payload has numbers of layers, in which order decoding, for each primary stream. Time stamp resolution MPEG-4 of the MPG-4 system should not be used as scale and SRTP. RCTP report, which refers to the technique used by RTP to streams, must be synchronized. When in the MPEG-4 object timer reference is used, RTCP-time axis linked to the network time protocol.

**3. Encryption Cypher**

The Rijndael planned for AES [7] well-defined a cipher in which the block length and key length can be individually specified to be 128,192 or 256 bits. The AES requirement uses the same three key size optional but restrict the block length upto 128 bits. Stream AES cipher techniques is used in video streaming on the multimedia network. A stream AES cipher is a symmetric encryption algorithm in which cipher data output is generated bit-by-bit or byte-by-byte from a stream of data input. AES cipher algorithm is used for Provided that the data security over internet. AES Cipher Feedback (CFB) [8] algorithm is used for general-purpose stream-oriented transmission and provides the authentication. A stream cipher eliminates the need to pad a message to be an integral number of blocks. This is used to operate in real time. In a method a character stream is being transmitted, each character can be encrypted and transmitted immediately using a character-oriented stream cipher. In the encryption side, the input is a b-bit shift register that is initially set to some initialization vector (IV). The leftmost s bits of the output of the encryption function are XORed with the first segment of plaintext P1 to produce the first unit of cipher text C1, which is then transmitted.

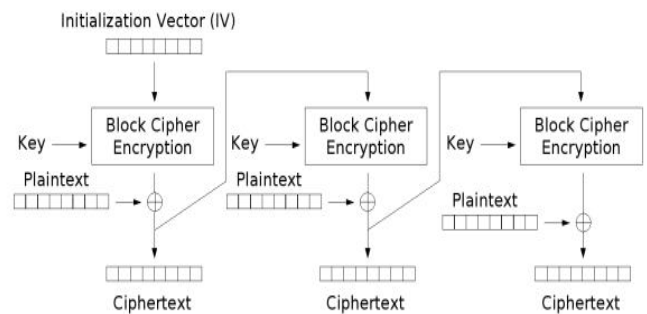

Figure 4. Cipher Feedback mode encryption

**4. SRTP encryption on packet**

In our planned system, we have an encryption technique to be modified RTP payload format area in the SRTP packet. The work, the implementation of eiesa Esaaratipi - CBC encryption algorithms, and algorithms eeiesa-used to be the chief. In our projected system, we will be instigating AES-CFB encryption and decryption algorithm to stream video. Previous algorithm to encrypt the video file problem when it is encrypted from block to block, and it gave normal block-based transmission. Eiesa-CFB- The strip cipher bit will be encrypted by bit or bit by bit. The advantage of installing CFB stream based data transmission algorithm, and this advanced encryption standard is sent for more security than CBC and CM mode.

**5. Application layer QOS**

Application layer of packet damage is to avoid the presence of QOS control transmission and the presence of maximum video quality. Braking application layer includes QOS control strategy control and error control. This is not required by the previous technology system employed and the network to support any QOS. For video streaming, there is a collection of results in the form of crowd control controls. There are three kinds of rate controllers depending on the source, and hybrid receiver-based rate control. Rate control for the control of other two appropriate video rates for the unicast and multicast video source. Unicode video streaming, model-based approach is based on the flow of a UDP connection. Used by RTT for connections of MTU packet size connections, round trip times and packet loss ratio experienced by connection. Determine the rate of the video stream, the equation sent. Hence, in a way that the video linking is like to the UDP clot and it can play fairly with the UDP stream.

### 6. Secure Video Stream Evaluation

The transmission of our proposed system, video data, it will provide a safe delivery. Video data transfer security and video data transmission will be a few seconds to make security time difference. We can secure our system of encryption technology and distribute unsafe video streaming broadcasts. This time it will take a secure video streaming file in non-secure video streaming over time (seconds), but it will send secure video data, a reliable client-server network.

### III. CONCLUSIONS

RTP server applications transmit captured or stored median streams across the network. The main challenge in designing a video streaming application across the multimedia networks is how to deliver video streams to users with minimal replay jitters with video data security and efficient video data transmission. The media streams might be encoded in multiple media formats and sent out on several RTP sessions for conferencing with heterogeneous receivers. This paper describes a framework for video streaming services using RTP through the client-server network.

### IV. ACKNOWLEDGEMENT

This work has been carried out as a part Master degree in Computer Science Engineering from RKDF Institute of Science and Technology, Hoshangabad Road, Bhopal, Madhya Pradesh. We would like to thanks our family, friends and specially Management, Principal, HOD and all teaching and non-teaching staff of Department for their support and guidelines.

### REFERENCES

- [1] Abdemhim benslimane, "Real-Time Multimedia Services over Internet", IEEE, pp 253-261, 2000.
- [2] sony corporation "Streaming and Recording Capabilities", video communication system-technical documentation, vol. 1.1, August 2008.
- [3] Prof. Nitin. R. Talhar, Prof. Mrs. K. S. Thakare," Real-time and Object-based Video Streaming Techniques with Application to Communication System", International Symposium on Computing, Communication, and Control (ISCCC 2009) Proc .of CSIT, vol.1, pages 25-29, 2011.
- [4] Hatem BETTAHAR," Tutorial on Multicast Video Streaming Techniques", 3rd International Conference: Sciences of Electronic, Technologies of Information and Telecommunications March 27-31, 2005 – TUNISIA.
- [5] Eugene T. Lin, Christine I. Podilchuk, Ton Kalker, Edward J. Delp, "Streaming video and rate scalable compression: what are the challenges for watermarking", 2006.
- [6] Abhik Majumdar, Igor V. Kozintsev," Multicast and Unicast Real-Time Video Streaming Over Wireless LANs", IEEE transactions on circuits and systems for video technology, vol. 12, no. 6, june 2002.
- [7] Lei Chen, Chung-wei Lee "Multi-level secure video streaming over SRTP," Proceedings of the 43rd ACM Southwest Conference, Kennesaw, GA, USA, March 18-20, 2005.
- [8] I. Richardson, An overview of H.264 Advanced Video, [Online]. Available: <http://www.vcodex.com>,2007.
- [9] H. Schulzrinne, S. Casner, R. Frederick, and V. Jacobson, "RTP: A Transport Protocol for Real-Time Applications," IETF RFC 3550, 2003.
- [10] M. Baugher, D. McGrew, M. Naslund, E. Carrara, and K. Norrman, "The Secure Real-time Transport Protocol (SRTP)," RFC 3711, 2004.
- [11] C. Perkins, RTP: Audio and Video for the Internet, Addison Wesley, 2003.
- [12] H. Schulzrinne, A. Rao, and R. Lanphier, "Real Time Streaming Protocol (RTSP)," IETF RFC 2326 (proposed standard), Apr. 1998. [Online]. Available:

<http://www.ietf.org/rfc/rfc2326.txt>

[13] J. Daemen and V. Rijmen, “AES Proposal: Rijndael,”  
February 2002.

[14] William Stallings, “Cryptography and network Security”  
fourth Edition, 2006.