

Knock Based Security System

Asst. Prof. Sagar Janokar¹, Mr. Aditya Naik², Mr. Jitesh Patil³, Mr. Samarth Rathian⁴, Mr. Vikrant Naik⁵

^{1,2,3,4,5} Dept of Electronics Engineering

^{1,2,3,4,5} Vishwakarma Institute of Technology, Pune

Abstract- The basic idea behind the project is to provide security to people on just the knocks. The knock pattern is detected and locking and unlocking is done on that basis. It's a small idea with a vast application and hence chances of holding the future market. Being a fascinating concept the problem being complexly coding it for the proper usage. Whereas our project being a prototype, it stands up for simple coding and hence some basic features. In the code, there needs to be an interfacing done between the knocks and the door locking mechanism. Our code provides the user to knock as per their preference and hence the door unlocks. The future scope brings in complex coding where there is a pattern of knocks detected initially, saved and used on whenever the knock pattern is played on the door. It's interesting, but with an initial stage and prototype the features provided are less on the whole. In the near future, it may also include image processing for helping to provide a more secure environment.

Keywords- Introduction, Related Work, Technique, Block Diagram, Circuit Diagram, Performance and Characteristics, Results, Conclusion, References.

I. INTRODUCTION

Security has always been a major concern of almost every sector in the society. In the recent years, with the increase in the amount of crimes such as thefts, robberies and even destructions and murders it has been one of the major agendas of every household and industrial discussion.

Hence, given this need many approaches have yielding successful results with highly secure locks. But to the dismay of many customers they have been very expensive. Though high end customers opted for these locks, the moderate ones were still left dangling. A major flaw in these locks was that it took a long time to open and close these locks either using keys or digital numbers. Hence a major breakthrough was fingerprint locking system. But again the prices soared tad higher than the budget of medieval customers creating a major drawback.

Keeping all these factors in mind we have come up with a new unlocking technique which takes traditional knocks as input and unlocks as per a particular pattern set by the user. [3] This approach is quite simple and way in the

budget of even small-scale customers providing similar security along with a new interesting element of knocks! [5]

II. MAIN BODY

A: Technique

The idea behind the project is quite simple and can be efficiently carried out. The technique involved is also straight forward. The whole project is heavily dependent on appropriate connections and the code. A microcontroller is used to conduct the whole procedure of the locking and unlocking. A piezoelectric sensor is attached to the Arduino. It sends the signals received by the knocks to the Arduino. [8] The Arduino detects the signals and matches it with the pre-stored sequence of knocks. Once it matches, the Arduino signals the Servo to rotate such that the system is unlocked.

These two devices formed the backbone of the implementation of this idea.

- **Arduino** is a single-board microcontroller, intended to make the application of interactive objects or environments more accessible. [1] The hardware consists of an open-source hardware board designed around an 8-bit Atmel AVR microcontroller, or a 32-bit Atmel ARM. Current models feature a USB interface, 6 analog input pins, as well as 14 digital I/O pins which allow the user to attach various extension boards.
- **A piezoelectric sensor** is a device that uses the piezoelectric effect, to measure changes in pressure, acceleration, strain or force by converting them to an electrical charge. Piezoelectric sensors have proven to be versatile tools for the measurement of various processes.

B: Block diagram

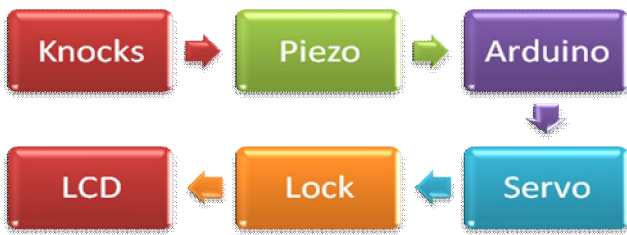

- **Knocks:** This is the input by the user in a particular pattern of knocks.
- **Piezo:** This will sense the knocks and convert it into electrical voltage digitally and send it to the microcontroller.
- **Arduino:** Microcontroller that reads the input voltages from the piezo and compares it with the pre-stored pattern and decides whether to unlock the mechanism.
- **Servo:** Takes the orders from the microcontroller and accordingly rotates to mechanically lock or unlock.
- **LCD:** Displays subsequent messages to the user according to the process being carried out.

C: Circuit Diagram

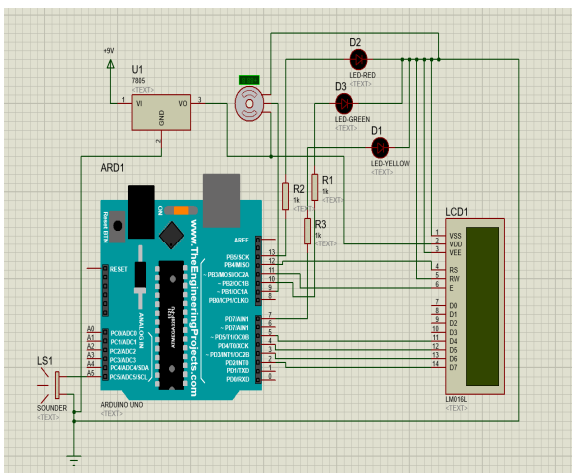

III. RESULTS

Table 1: Switch and Servo

S.No	Switch Pin	Servo Angle	Status
1	0	0	Unlocked
2	1	90	Locked

Switch Characteristics

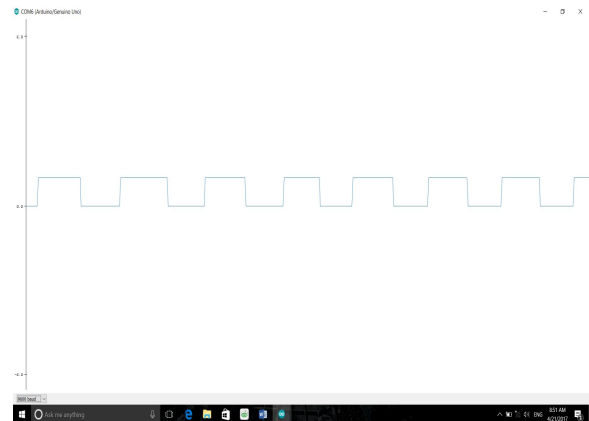

Servo Characteristics

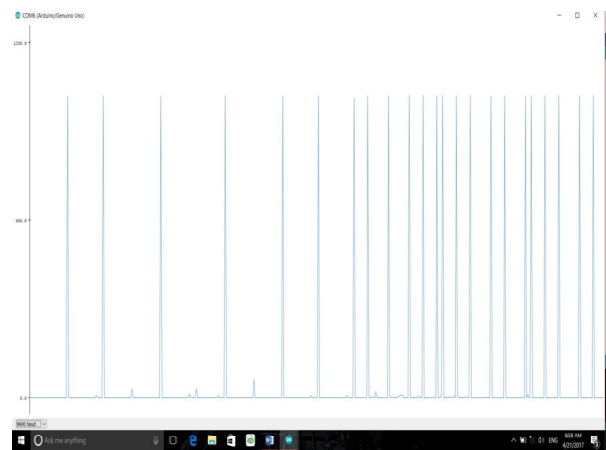
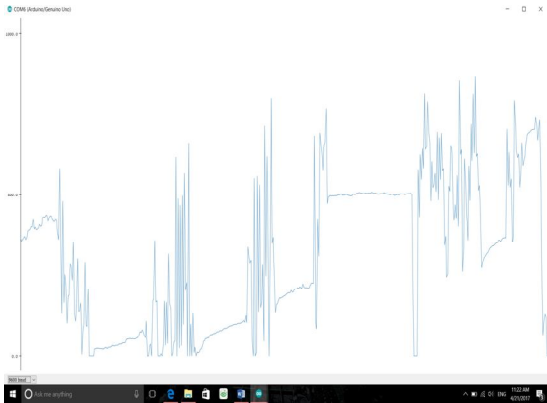

Table2: Piezo and Servo

S. No	Piezo	Servo Angle	Status
1	0	90	Locked
2	930	90	Locked
3	920	90	Locked
4	940	0	Unlocked

Piezo Characteristics (Analog)



(Note: Though this sensor gives analog values, only digital values were considered using built in ADC in the Arduino)

IV. RESULT ANALYSIS

The graphs explain a couple of things that are worth noticing. These graphs give a basic idea of the nature of the data transmitted to the Arduino.

- Output of the switch shows that it transmits digital values giving square waves constantly.
- Given the graphs of the piezo electric material, we can conclude that it transmits analog values to the Arduino for processing.

V. CONCLUSION

On the whole, this method is still in the beta stage of as the mechanical attachments have not yet implemented. But this method proves to be fairly efficient and cost effective. The time taken to lock and unlock is reduced by large and helps to ease the access.

The market for this product is also quite demanding and can be really helpful to the masses. The product is fully tested and all aspects have been recorded.

VI. ACKNOWLEDGMENT

We would like to take this opportunity to express our profound gratitude and deep regards to our Project Guide Asst. Prof. Sagar Janokar for his exemplary guidance, valuable feedback and constant encouragement throughout the duration of this project. His valuable suggestions were of immense help throughout the project work. His perceptive criticism kept us working to make this project in a much better way. Working under him was an extremely knowledgeable experience for us.

We would also like to give our sincere gratitude to all the friends and colleagues who actively participated in knowledge - sharing and support without which this research would be incomplete.

REFERENCES

- [1] "Controlling and securing a Digital Home using Multiple Sensor Based Perception system Integrated with Mobile and Voice technology", Avishek Ahmed, 2 Tanvir Ahmed, 3 Md. Samawatullah, 4 Md. Manirul Islam
- [2] "Microcontroller based Home Security System with Remote Monitoring", Nikhil Agarwal, Department of EC Engineering MIT, Manipal.
- [3] "A Review on Industrial Automation By Zigbee Based Wireless Remote Controller", Minal Nikose, Pratibha Mishra, Avinash Agrawal.
- [4] "Energy efficient Smart home based on Wireless Sensor Network using LabVIEW", Jayashri Bangali, 2 Arvind Shaligram.
- [5] "A Remote Home Security System Based on Wireless Sensor Network and GSM Technology", Wuhan, Hubei.
- [6] "Sensor based home automation and security system", Instrumentation and Measurement Technology Conference (I2MTC), 2012 IEEE International.
- [7] "Sensor based home automation and security system", Instrumentation and Measurement Technology Conference (I2MTC), 2012 IEEE International.
- [8] "Arduino Based industrial security system using piezo electric sensor", Rupinder Singh Brar.
- [9] "Knock detecting door lock", D.G.U.I Wickramarathna, D.G.C.D Wijerathna, Y.M.S.N Wijayarathna, W.M.N.C Wijebandara.
- [10] "Knock Sensing door lock", Ms. Gunjan Jewani, Prof. Shubhangi Borkar 1,2 Department of Computer science & Engineering 1,2 Nagpur Institute of Technology, Nagpur.

Data Sheets

- Piezo
- Servo (MG995 Tower Pro)
- Arduino Uno (Atmega 128)
- LM016L (LCD Display)
- 5V Regulator (7805)
- LED (COM-09590)
- Push Button (PB59)