

A Modern Topology of Bidirectional DC-DC Converter For Deduction In Leakage Current

Prakash Narayan Verma¹, Kumar Goswami²

¹Dept of Electrical Engineering

²Dept of ECE

¹MANIT, Bhopal

²MATS University, Raipur

Abstract- This paper propose modified D.A.B. topology in which a tuned L-C-L (Inductor-Capacitor-Inductor) Network. This method proposes a topology in which number of switches operating at a time is reduced by making use of the breaker circuit and hence switching losses are reduced modified topology is investigated under simulated environment by using SIMULINK. Further this topology proposes a way to reduce leakage current by adjusting the gain of D.A.B. Results obtained shows reduction in switching losses as well as leakage current of D.A.B. , Results indicates that the finally leakage current get reduced after Applying this proposed method by using the different kind of controller to control the pulses of the semiconductor switches.

Keywords- DC-DC Converter, ANN, PID controller, D.A.B. converter, L-C-L passive resonant converter, Breaker.

I. INTRODUCTION

In recent time the world is phase the problem of generation of electricity, recently the most of the energy can be depends on the conventional energy sources like petrol, diesel, gases and the also nuclear. But this type of energy can be limited in nature and after some time the level is very high so that the consumption of the energy is very high. But the generation of the electricity can be also be developed by the external source which is also called a natural energy like solar energy, wind energy, bio diesel, ocean energy and geothermal energy source[1], these type of energy is nonconventional energy sources and these energy can be very eco-friendly in nature But this type of energy is variable in nature so that developing source and the load generated mismatching. These mismatching is compulsory to reduce because of if it is not reduced then the stability of the system is getting decrease. So bidirectional process is best one for the improved the stability of the system and it developed the interface between the power grid to electrical vehicle system. So energy transfer is easy for this type of system[2-5].

Different kind of converter is applicable for the vehicle to grid system, but the dual active bridge DC-DC

converter is most important and the most preferable D.A.B. converter. The most important quality of the dual active bridge converter is that its provides a isolation circuit between then and using small number of components at the time of conversion and also its improve the high power transfer or operation [6] -[7]. The other use of the dual active bridge is that it can be used for wide range voltage level, and if we used the these type of converter then we can operated with both of the mode as voltage decrement mode or also called a Buck mode and the Voltage increment mode also called the Boost mode, so that its operated at both of the mode. In conventional converter D.A.B. converter is using the single phase shift operation [8]. The main drawback of the conventional dual active bridge topology is that it takes more reactive current and the current is the responsible quantity for generation of the losses in the circuit so that the reactive current is also generated the conduction loss. For compensation this reactive current can be reduced by the large dc-link capacitor for minimizing the value of current [9]-[10]. And in the conventional D.A.B. technology the reactive current can be reduced by different kind of techniques like using by the pulse width modulation techniques or also by the zero voltage switching(ZVS) or provided by the different type of signal to the semiconductor switches like trapezoidal or triangular signal to minimizing the reactive current and reduction of conduction losses of the circuit[12], for reduced the level of current in the dual active bridge it is the required condition to achieving zero current switching in some of the switches[13] , [14], the level of reactive power can be also reduced by the to get equal pulse width modulation in each bridges[11], for minimization of the reactive power and root mean square value and peak value of the current can be reduction is possible by the controlling the switching condition[10] , for this system as compared to the dual phase shift control compare to pulse width modulation is used. Because of the converter efficiency is higher if we used the different signal using to operate the switches as compare to phase shift operation between the bridges. In traditional mostly pulse width modulation techniques is used for the operated the switches but if the switches can be operated smooth and if want to reduced the level of reactive current of the circuit or

minimizing the conduction losses of the switched applied different kind of controller for controlling the switching action. The efficiency varies 77% at a 3% load through to approximate 90% when the condition is operated at the full load is achieved. So in the circuit using the resonant condition which is developed by the tuning circuit or filter circuit, have been proposed.

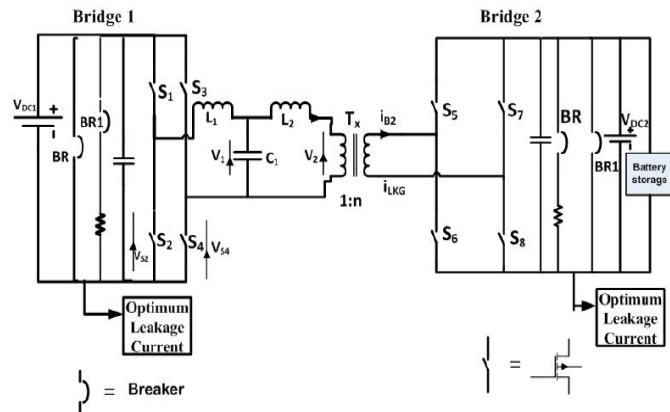

Fig 1 :- Proposed dual active bridge topology circuit

The most important work of this topology is that its extend the level of soft switching level of the circuit and reduced the eddy current losses which is developed by the transformer winding or also say that it reduced the level of fluctuation of the signal and improved the current signal of the bridge[19]-[22]. Conventional D.A.B. topology draws more reactive current at full power. And hence the level of conduction losses is increases very fast.

This paper indicated the level of leakage current which is developed in the circuit and propose a new dual active bridge topology, this D.A.B. topology is using the phenomena of resonant network to reduce the level of leakage current of the bridge and also reduced the conduction loss of the circuit and improved the efficiency. For resonant network paper present a new inductor-capacitor-inductor configuration circuit. Which is providing to the transformer circuit in proposed topology transformer is using the as a isolation circuit and rising and decrement the level of voltage level range. So that L-C-L combination is also be used to minimizing the fluctuation the signal when it's converted the DC into ac signal. Each bridge is operated by the different kind of controller. In proposed system used a 2.5 kW prototype system, in the proposed topology the bidirectional conduction is possible because of the resonantcondition satisfied here. So energy can be transferred of theproposed system is bidirectional power at high efficiency and achieved the wide range of power and DC voltage range.

II. PROPOSED METHOD

A proposed topology of bidirectional DC-DC converter is shown in the figure 1, in this D.A.B. topology there are eight number of semiconductor switches represented in S1 to S8, in proposed topology metallic oxide semiconductor field effect transistor is used for switching action. There are two side of the bridges. In these topology two types of mode is present, first is forward mode and second is reverse mode conduction,

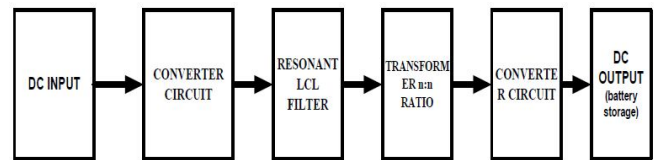

Fig 2 :- Block diagram of Forward Mode Conduction

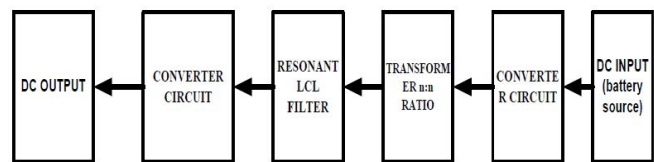

Fig 2 :- Block diagram of Reverse Mode Conduction

in forward mode conduction VDC1 is act a source terminal which can be added to the nonconventional sources like solar or wind so that the VDC1 voltage is developed by the renewable source and the VDC2 is like a load circuit in these side the as a load used a hybrid electrical vehicle. So for drive the load we used the hybrid electrical vehicle which is represented by the source VDC2. And the output of the converter is stored to the battery circuit which can be used as per requirement. Furthermore, L2 is the leakage inductor of the transformer. Primary side of the converter is represented by the Bridge 1, which is operated in a constant frequency which is represented by the f_s . when the constant DC source is provided to the converter circuit then if the controller is operated the semiconductor switches then its generated the controlled ac signal which is represented by the V_1 , and the generated ac in theses case is fluctuating in nature so that a inductor-capacitor-inductor (L-C-L) network is used to decreases the fluctuation in ac and provided to the pure ac signal to isolation transformer. The developed voltage across the primary side of the transformer is V_2 . The two ac sources are connected together through the transformer and the filter network.

Combination of inductor and capacitor get reduced the switching loss and improved the efficiency of the circuit and its also improvise the soft switching level of the circuit. In traditional dual active bridge converter a quasi square signal is

used for the controlled signal to switches if the conventional converter is used. The converter is using the function of resonant condition because of present a passive elements here. For controlling the switches different kind of the control scheme is used or different modulation scheme is used [19-22]. For propose topology for controlling the switching pulses used the PID controller and the applying the neural network. However as a result of resonant L1C1L2 network is used. In the proposed system flow of the power and magnitude of the voltage is totally depend on the switching controlling system which is provided by the controller switches. Switches S1 and the switch S2 is in phase shifting condition. And the switch S3 and switch S4 is same as a condition. When provided the dc signal to the converter circuit then its converter into the ac but in fluctuating in nature these is reduced by the tuned resonating filter. And its provide to the transformer as a input a Tx is n:1 transformer for VDC1 a input signal its beehives like a step down and provided these value to the again converter circuit which can be converted this AC into DC signal for the minimizing the ripple capacitor is used and these value is utilized by the a load VDC2 and stored in a battery. Here neural or PID controller is used for the controlling the action of switches.

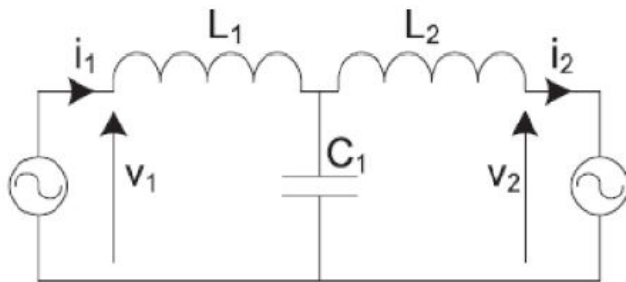

Fig 3 :- New Dual Active Bridge Topology

For the controlled action two type of breaker circuit is used BR and BR1 breaker, in proposed topology by using of PID or neural network at that time only breaker can be operated so that if we used the buck mode then breaker BR is operated and its using only two switches at that time switch S1 and switch S4 are operated when the breaker BR is operated. And when the reverse mode or boost mode is operated the breaker BR1 IS operated at that time so that its also used the two switches for the conduction of current. So if the breaker can reduce the utilization ratio of the switched, then the number of operated switches is reduced at the time and the conduction loss of switches are reduced of the circuit. And hence the efficiency of the circuit is improved. Figure 2 and figure 3 illustrate the block diagram of the proposed topology which is work on the two mode, figure 2 is for proposed forward mode to how to power flow on forward mode conduction and the figure 3 is for proposed reversed mode

condition to how to power and voltage will generated when the condition of resonant is used. So the breaker BR and the BR1 play vital role to improvising the voltage level and improve the power rating of the proposed Dual active bridge topology.

III. RESULTS

A prototype bidirectional dc-dc converter is tested and practically simulation result is shown on the below figures. If compare with the conventional type of converter the proposed topology have very accurate value of the output is developed. The time domain theoretical result can be obtained by the MATLAB result and evaluate the natural responses of the proposed dual active bridges. in compare to the conventional D.A.B topology the proposed topology has higher efficiency lower bridge current and the lower conduction losses. The bridge 1 is operated by the controller circuit for the control the pulses of the semiconductor switches. Here in proposed topology in a place of controller used the different kind of controller like a neural network and PID controller for controlling the pulses of the switches.

To demonstrate the ability of proposed method bridge 2 side have 4 switches arrangement S4 – S8 switches arrangement. The voltage generated in this side is also referred as a distortion voltage which has some harmonics distortion. figure 5. Illustrate the waveform of the secondary side of transformer or bridge 2 input sides. or developing the 2.5 kW of the power VDC1 and VDC2 are the two sources in the bidirectional process. When the forward mode is conducted VDC1 is behave like an input source and after the conversion of the signal VDC2 is work as a load side which can also referred as the battery storage side in the forward mode the converter is behaves like a step down channel.

TABLE 1 :- CIRCUIT PARAMETER OF SYSTEM

Parameter	Theoretical value	Experimental value
Rated power	2.5 kW	
V _{DC1}	380 V	
V _{DC2}	50 V	
Turns ratio n	7.54	
Magnetics	Ferro cube E65/32/27	
f _s	50KHz	
L ₁	145 μH	144 μH
L ₂	145 μH	146 μH
C ₁	69.8 nF	66 nF
HV Switches	FDP054N10 MOSFET	
LV SIDE	FDP054N10 MOSFET	

The generation of step down process of the converter the breaker input is provided to the 0 so that breaker BR is activated and the related dependent semiconductor switch is also operated in this case.

The best advantages of using breaker is that its operate only two switches at that time so that number of switches conduct at the time is reduced so that the current across the switches is getting decrease.

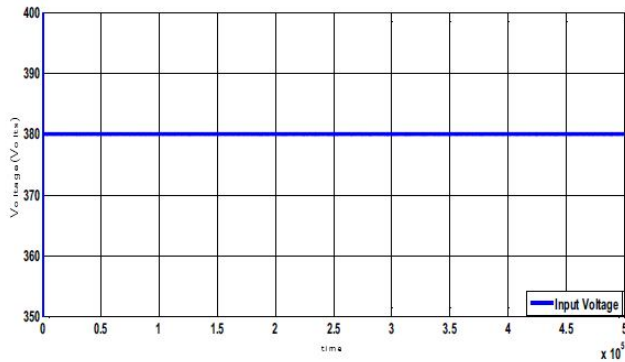

Fig 4: Input voltage forward mode with PID controller

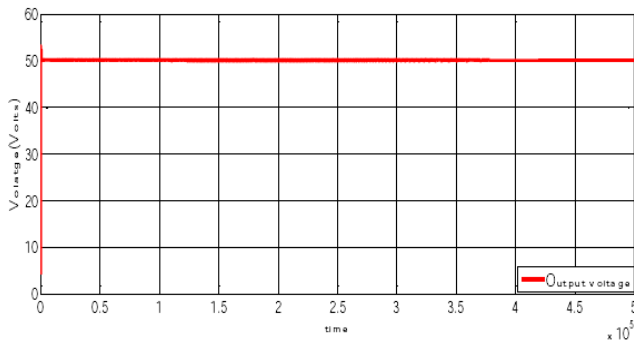

Fig 5: Output voltage of resonant converter (forward mode)

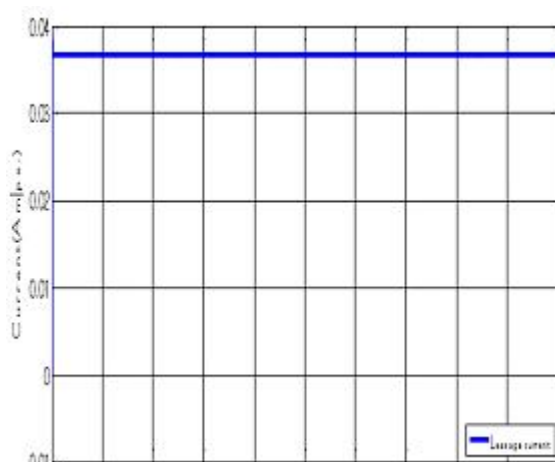

Fig 6: Leakage current level (forward mode) with PID controller

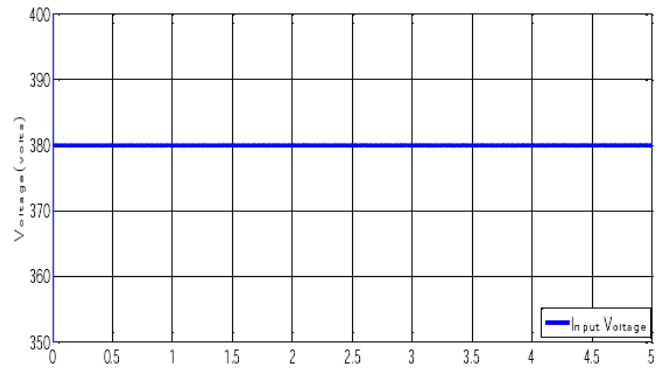

Fig 7 : Input voltage value for forward mode using ANN

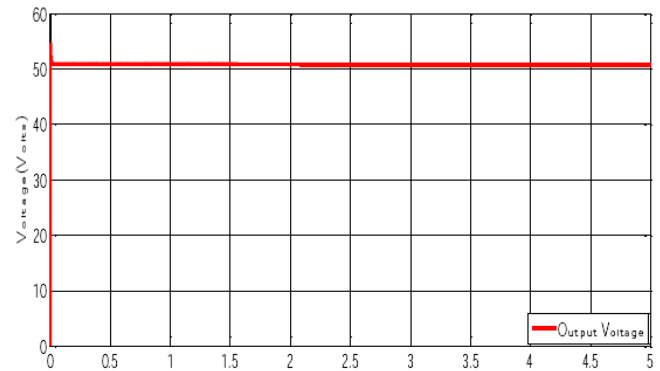

Fig 8: Output Voltage buck mode using ANN

The input voltage is presented in figure 7, output voltage of the system is represented on the figure 8. in these case for reduction of leakage current using the control the action of controller PID and neural network both type of controller is used so that the controller Leakage current system when using in ANN controller the output waveform can be represented by the figure 9.

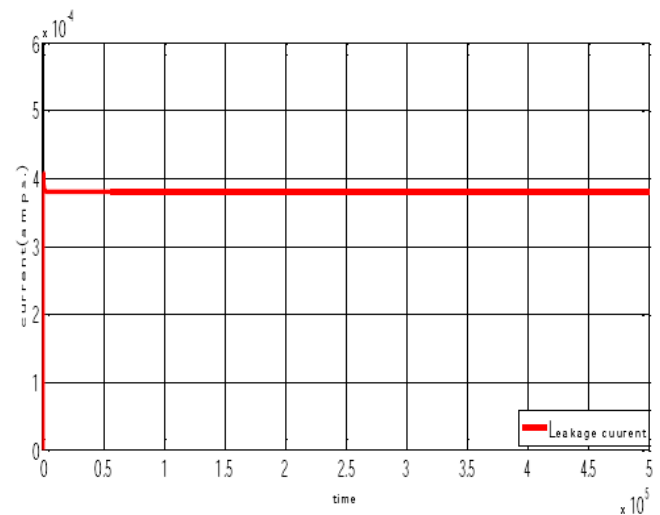

Fig 9: Leakage current level (forward mode) with ANN

So in this case the developed leakage current is in the forward mode by adjusting the gain constant decreasing the level of the leakage current. The output can be stored in the forward case by battery circuit or the ultra capacitor. So used by their consumer requirement. for increasing the level of voltages then using the neural network, in these case when the neural network is used for the controlling the switching action then the level of leakage current is decreases and the value of output voltage is increased which is presented in the figure 13.

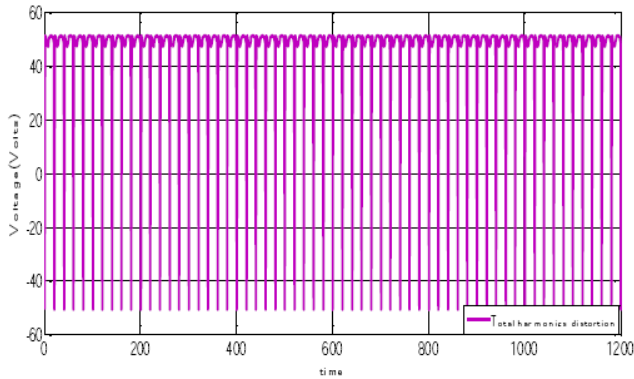

Fig 10: THD generation in buck mode

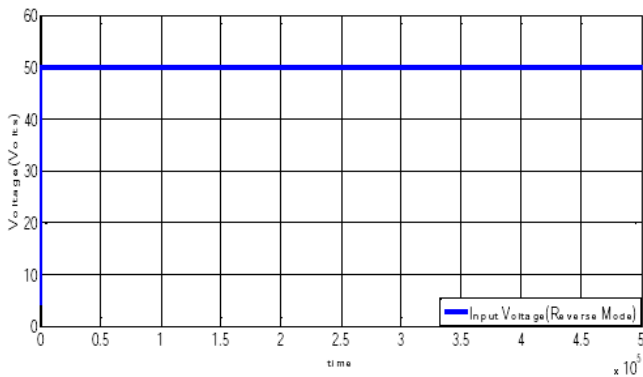

Fig 11: Input voltage condition (boost mode) using PID

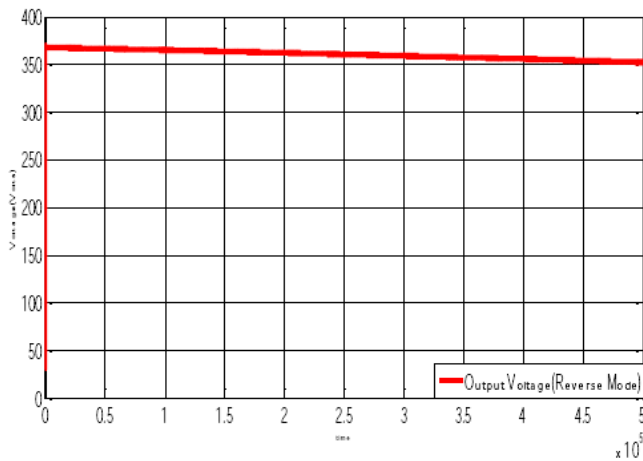

Fig 12: Output voltage level using PID controller

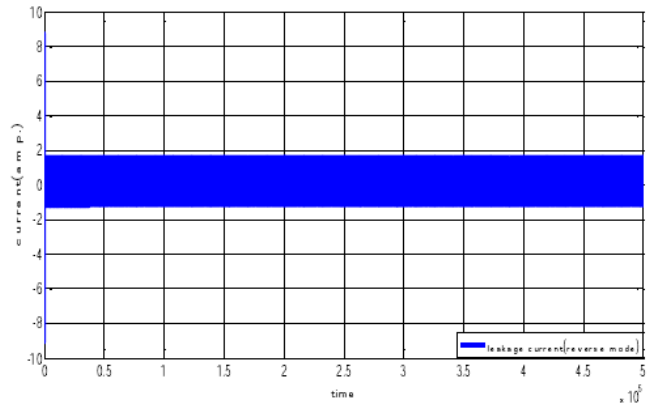

Fig 13: Leakage current reverse mode PID controller

When the 1 output is provided to the controller the reverse mode is operated. in this case breaker BR1 is operated and again 2 switches are only used for the conduction at that time so that in here also only two switches are getting conducted so level of bridge current is decreases in these case. when breaker BR1 is operated then the after conversion of dc into ac, then the step up process is generated by the transformer and in these case VDC2 is beehive like a source circuit and the VDC1 is a like a load. So that in this process bidirectional process is operated at the same time with changing the controller output. The input voltage figure 11, output voltage in figure 12 and the level of leakage current can be shown in the figure 13.

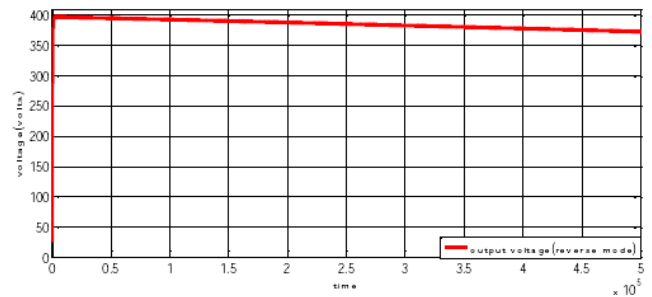

Fig 14: Battery output level voltage ANN reverse mode

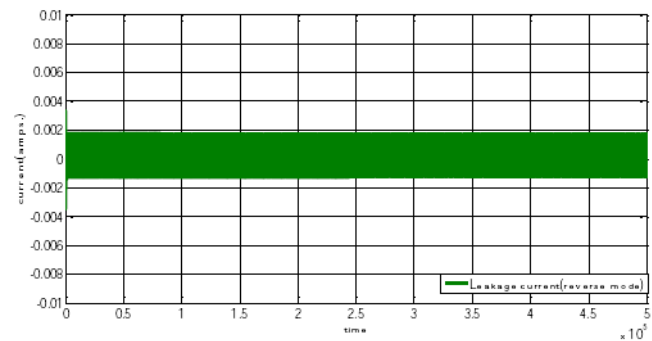

Fig 15: Leakage current level using ANN in reverse mode

these case is satisfied when the PID controller is used, when the neural is applied to the circuit so that the level of leakage current is decreases in these case and the value of output voltage is increases if compare to the PID controller. The level of leakage current in these can be seen in the figure 18. The level of the output voltage comparative analysis can be illustrating the figure. In the case of neural network the value of output current is always increases which are seen in the figure 16 & figure 17.

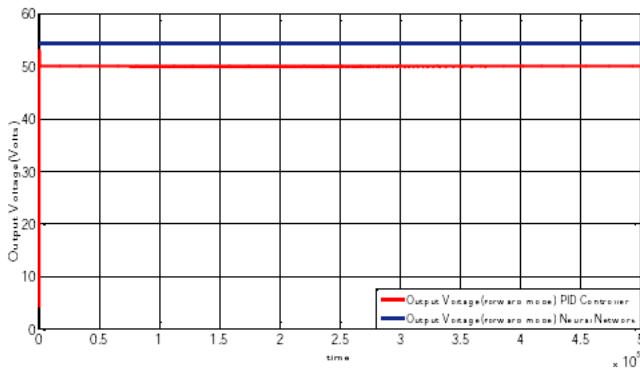

Fig 16: Comparison result of output voltage(forward mode)

The level of voltage can be boosted then the level of leakage current can be decrease which can be seen in the figure.

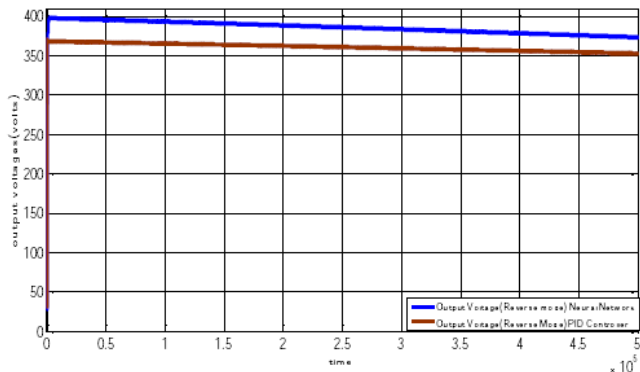

Fig 17: Comparison result of output voltage (reverse mode)

The level of leakage current can be decreases when the neural network is applied to controlling the pulses of the switches.

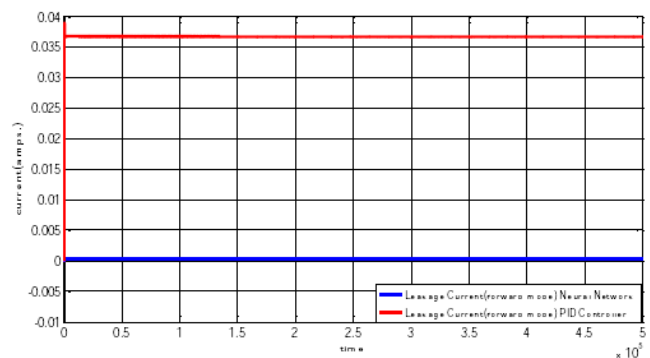

Fig 18: Leakage current comparison result

So that different kind of controlling circuit is applied to thecontrolling pulses and the comparative analysis output voltage of the circuit can be represented in the figure. and the level of leakage current can be also be decreases when the using of the neural network to the circuit which is illustrate the figure .in both the cases level of decrement of leakage current is good result. so that the comparison with the conventional D.A.B. topology the new bidirectional topology have good performance and improvement.

IV. CONCLUSION

New bidirectional resonant converter is proposed here with the using of the inductive capacitive inductive filter so that the both of the conduction is possible with using the resonance phenomena. A model of the D.A.B. technology is described by the above and mathematical result is shown as the above. In different condition we observed that a 2500watts can be generated if we consider this D.A.B. technology, and also described the performance of the constant current converter performance. Output of the two way DC-DC converter can be shows that its offers low conducting current. So if the level of current is getting reduced so that switches loss can be reduced so it's also improved the efficiency, and provides high level voltage in the output side in any of the side if we used as buck mode or boost mode as our requirement. So this proposed method is reduced leakage current and improved voltage level.

REFERENCES

- [1] Ross p thiwane, j.thrimawithana,k. madawala, craig A. baguley" A new resonant bidirectional DC-DC Converter topology" in proc. IEEE transaction on power electronics vol 29,sep 2014 pp.4733-4740
- [2] J. Marsden, "Distributed generation systems: A new paradigm for sustainable energy," in Proc. IEEE Green Technol. Conf., 2011, pp. 1–4

- [3] B. Kramer, S. Chakraborty, and B. Kroposki, "A review of plug-in vehicles and vehicle-to-grid capability," in Proc. IEEE Conf. Ind. Electron., 2008, pp.2278–2283.
- [4] U. K. Madawala and D. J. Thrimawithana, "A bidirectional inductive power interface for electric vehicles in V2G systems," IEEE Trans. Ind. Electron., vol. 58, no. 10, pp. 4789–4796, Oct. 2011.
- [5] D. J. Thrimawithana and U. K. Madawala, "A model for a multi-sourced green energy system," in Proc. IEEE Conf. Sustainable Energy Technol., 2010, pp. 1–6.
- [6] N. D. Weise, K. K. Mohapatra, and N. Mohan, "Universal utility interface for plug-in hybrid electric vehicles with vehicle-to-grid functionality," in Proc. IEEE Power Energy Soc. Gen. Meeting, 2010, pp. 1–8.
- [7] R. L. Steigerwald, R. W. De Doncker, and H. Kheraluwala, "A comparison of high-power DC-DC soft-switched converter topologies," IEEE Trans. Ind. Appl., vol. 32, no. 5, pp. 1139–1145, Sep./Oct. 1996.
- [8] D. Yu, S. Lukic, B. Jacobson, and A. Huang, "Review of high power isolated bi-directional DC-DC converters for PHEV/EV DC charging infrastructure," in Proc. IEEE Energy Convers. Congr. Expo., 2011, pp. 553–560.
- [9] R. W. A. A. De Doncker, D. M. Divan, and M. H. Kheraluwala, "A three-phase soft-switched high-power-density DC-DC converter for high power applications," IEEE Trans. Ind. Appl., vol. 27, no. 1, pp. 63–73, Jan./Feb. 1991.
- [10] B. Hua, N. Ziling, and C. C. Mi, "Experimental comparison of traditional phase-shift, dual-phase-shift, and model-based control of isolated bidirectional DC-DC converters," IEEE Trans. Power Electron., vol. 25, no. 6, pp. 1444–1449, Jun. 2010.
- [11] K. Myoungho, M. Rosekeit, S. Seung-Ki, and R. W. A. A. De Doncker, "A dual-phase-shift control strategy for dual-active-bridge DC-DC converter in wide voltage range," in Proc. IEEE Power Electron. Energy Convers. Congr. Expo. Asia, 2011, pp. 364–371.
- [12] G. G. Oggier, R. Ledhold, G. O. Garcia, A. R. Olivia, J. C. Blaba, and F. Barlow, "Extending the ZVS operating range of dual active bridge high power DC-DC converters," in Proc. IEEE Power Electron. Spec. Conf., 2006, pp. 1–7.
- [13] F. Krismer, S. Round, and J. W. Kolar, "Performance optimization of a high current dual active bridge with a wide operating voltage range," in Proc. IEEE Power Electron. Spec. Conf., 2006, pp. 1–7.
- [14] R. L. Steigerwald, "A review of soft-switching techniques in high performance DC power supplies," in Proc. IEEE Conf. Ind. Electron. Control Instrum., 1995, pp. 1–7.
- [15] B. Hua and C. Mi, "Eliminate reactive power and increase system efficiency of isolated bidirectional dual-active-bridge DC-DC converters 4740IEEE TRANSACTIONS ON POWER ELECTRONICS, VOL. 29, NO. 9, SEPTEMBER 2014 using novel dual-phase-shift control," IEEE Trans. Power Electron., vol. 23, no. 6, pp. 2905–2914, Nov. 2008.
- [16] G. G. Oggier, G. O. Garcia, and A. R. Oliva, "Switching control strategy to minimize dual active bridge converter losses," IEEE Trans. Power Electron., vol. 24, no. 7, pp. 1826–1838, Jul. 2009.
- [17] B. Zhao, Q. Song, and W. Liu, "Efficiency characterization and optimization of isolated bidirectional DC-DC converter based on dual-phase-shift control for DC distribution application," IEEE Trans. Power Electron., vol. 28, no. 4, pp. 1711–1727, Apr. 2013.
- [18] G. G. Oggier, G. O. Garci, and A. R. Oliva, "Modulation strategy to operate the dual active bridge DC-DC converter under soft switching in the whole operating range," IEEE Trans. Power Electron., vol. 26, no. 4, pp.1228–1236, Apr. 2011.
- [19] A. K. Jain and R. Ayyanar, "PWM control of dual active bridge: Comprehensive analysis and experimental verification," IEEE Trans. Power Electron., vol. 26, no. 4, pp. 1215–1227, Apr. 2011.
- [20] R. Lenke, F. Mura, and R. W. A. De Doncker, "Comparison of nonresonant and super-resonant dual-active ZVS-operated high-power DC-DC converters," in Proc. IEEE Conf. Power Electron. Appl., 2009, pp. 1–10.
- [21] C. Wei, S. Wang, X. Hong, Z. Lu, and S. Ye, "Fully soft-switched bidirectional resonant dc-dc converter with a new CLLC tank," in Proc. IEEE Appl. Power Electron. Conf. Expo., 2010, pp. 1238–1241.
- [22] L. Corradini, D. Seltzer, D. Bloomquist, R. Zane, D. Maksimovic, and B. Jacobson, "Minimum current operation of bidirectional dual-bridge series resonant DC/DC converters," IEEE Trans. Power Electron., vol. 27, no. 7, pp. 3266–3276, Jul. 2012.