

An Observer-Based Optimal Voltage Control Scheme for Three-Phase UPS Systems

Surabhi S Deshmukh¹, C. O. Reddy²

^{1,2} Department of Electrical Engineering

^{1,2} MSS-CET, Jalna

Abstract- This paper proposes a simple optimal voltage control method for three-phase uninterruptible power-supply systems. The proposed voltage controller is composed of a feedback control term and a compensating control term. The former term is designed to make the system errors converge to zero, whereas the latter term is applied to compensate for the system uncertainties. Moreover, the optimal load current observer is used to optimize system cost and reliability. Particularly, the closed-loop stability of an observer-based optimal voltage control law is mathematically proven by showing that the whole states of the augmented observer-based control system errors exponentially converge to zero. Unlike previous algorithms, the proposed method can make a tradeoff between control input magnitude and tracking error by simply choosing proper performance indexes. The effectiveness of the proposed controller is validated through simulations on MATLAB/Simulink and experiments on a prototype 600-VA test bed with a TMS320LF28335 DSP. Finally, the comparative results for the proposed scheme and the conventional feedback linearization control scheme are presented to demonstrate that the proposed algorithm achieves an excellent performance such as fast transient response, small steady-state error, and low total harmonic distortion under load step change, unbalanced load, and nonlinear load with the parameter variations.

Keywords- Optimal load current observer, optimal voltage control, three-phase inverter, total harmonic distortion (THD), uninterruptible power supply (UPS).

I. INTRODUCTION

Uninterruptible Power Supply (UPS) systems supply emergency power in case of utility power failures. Recently, the importance of the UPS systems has been intensified more and more due to the increase of sensitive and critical applications such as communication systems, medical equipment, semiconductor manufacturing systems, and data processing systems. These applications require clean power and high reliability regardless of the electric power failures and distorted utility supply voltage. Thus, the performance of the UPS systems is usually evaluated in terms of the total harmonic distortion (THD) of the output voltage and the

transient/steady state responses regardless of the load conditions: load step change, linear load, and nonlinear load. Repetitive control is applied to achieve a high-quality sinusoidal output voltage of a three-phase UPS system. Generally, this control technique has a slow response time. In the adaptive control method with low THD is proposed; nevertheless, there is still a risk of divergence if the controller gains are not properly selected. In Multivariable FLC control technique, the nonlinearity of the system is considered to achieve low THD under nonlinear load. However, it is not easy to carry out due to the computation complexities.

The optimal control design gives the optimality of the controller according to a quadratic performance criterion and enables the control system to have good properties such as enough gain and phase margin, robustness to uncertainties, good tolerance of nonlinearities, etc. Hence, a linear optimal controller has not only a simple structure in comparison with other controllers but also a remarkable control performance similar to other nonlinear controllers. Therefore, this paper proposes an observer-based optimal voltage control scheme for three-phase UPS systems. This proposed voltage controller encapsulates two main parts: a feedback control term and a compensating control term. The former term is designed to make the system errors converge to zero, and the latter term is applied to estimate the system uncertainties. Specially, this paper proves the closed loop stability of an observer-based optimal voltage control law by showing that the system errors exponentially converge to zero. Moreover, the proposed control law can be systematically designed taking into consideration a tradeoff between control input magnitudes and tracking error unlike previous algorithms. The efficiency of the proposed control method is verified via simulations on MATLAB/Simulink and experiments on a prototype 600-VA UPS inverter tested with a TMS320LF28335 DSP. In this paper, a conventional FLC method in is selected to demonstrate the comparative results because it has a good performance under a nonlinear-load condition, and its circuit model of a three-phase inverter in is similar to our system model. Finally, the results clearly show that the proposed scheme has a good voltage regulation capability such as fast transient behavior, small steady-state error, and low THD under various load conditions such as load step change,

unbalanced load, and nonlinear load in the existence of the parameter variations.

II. HARMONIC COMPENSATION

Within the system, active filters can be used to provide suitable harmonic compensation for voltage harmonics and current harmonics. These harmonic are the most important variable requiring compensation.

a) Compensation of voltage harmonics:

In general, the concern for compensating voltage harmonics is not high due to the fact that power supplies usually have low impedance. Generally, at the point of common coupling, ridged standards are implemented to ensure a correct level of total harmonic distortion (THD) and voltage regulation is maintained. The problem of compensating for voltage harmonics is to ensure the supply to be purely sinusoidal. This is important for harmonic voltage sensitive devices such as power system protection devices and superconducting magnetic energy storage. Voltage harmonics are related to current harmonics by the impedance of the line. Although compensation of voltage harmonics helps to provide a reduction in current harmonics, this however, does not negate the necessity to current harmonic compensation.

b) Compensation of current harmonics:

Current harmonic compensation strategies are exceptionally important, current harmonics are greatly reduced by the compensation of voltage harmonics at the consumer's point of common coupling. The reduction in current harmonics is not only important for reasons such as device heating and reduction in life of devices but also in design of power system equipment. One of the major design criteria covers the magnitude of the current and its waveform. This is to reduce cable and feeder losses. Since the root mean square (RMS) of the load current incorporates the sum of squares of individual harmonics, true current harmonic compensation will aid system designers for better approached power rating equipment.

III. SYSTEM MODEL

The system considered for simulation is a three-phase balanced source supplying a Diode bridge rectifier feeding a resistive-inductive load, as shown in Fig. 1. This load draws a highly nonlinear current rich in harmonics with a substantial reactive power requirement. A three phase, VSI-based shunt AF is connected to the system for reactive power

compensation and harmonics elimination. The simulation is performed in the Simulink/MATLAB environment.

Fig. shows the basic simulation model of 3 LEG STACK CELL (STATCOM) This 3 LEG STACK CELL (STATCOM) model is simulated with the above described p-q, SRF based theories. Simulation models for these theories that are inconsistent with the control schemes.

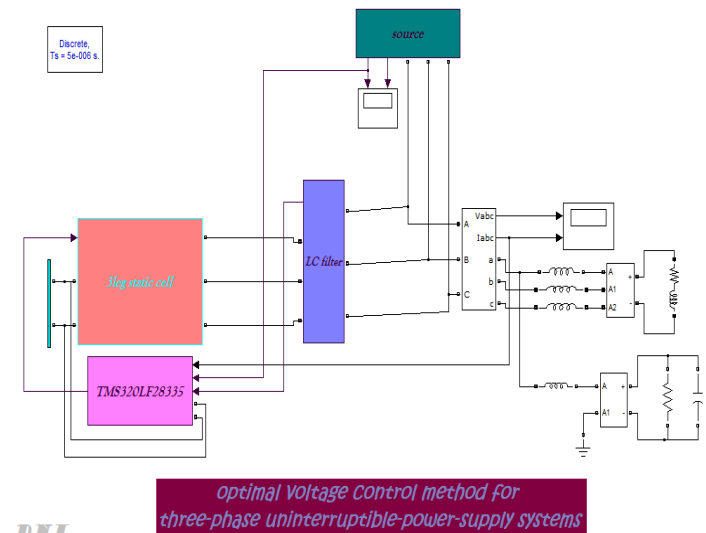

Figure 1. Simulation block diagram of 3 LEG STACK CELL (STATCOM)

The operation of the 3 LEG STACK CELL (STATCOM) system requires ac mains to supply real power needed to the load and some losses (switching losses of devices, losses in the reactor, and dielectric losses of dc capacitor) in the 3 leg stack cell (STATCOM). The reference source currents are used to decide the switching of the 3 leg stack cell (STATCOM).

IV. DSP BASED PULSE GENERATION

To deal with instantaneous voltages and currents in three phase circuits mathematically, it is adequate to express their quantities as the instantaneous space vectors. For simplicity, the three-phase voltages and currents excluding zero-phase sequence components will be considered in the following the DSP TMS320LF28335 DSP model is used for control the current and the voltage in the system this DSP model is used to generate the pulses which is used to required to the statcom which can be produce the stability or the unbalanced system

Probably TMS320LF28335 DSP is designed by the following two theories; 1. Instantaneous Reactive Power (IRP) Theory. 2. Synchronous Rotating Frame (SRF) Theory

These theories are used to generate the reference current and the voltage in the system

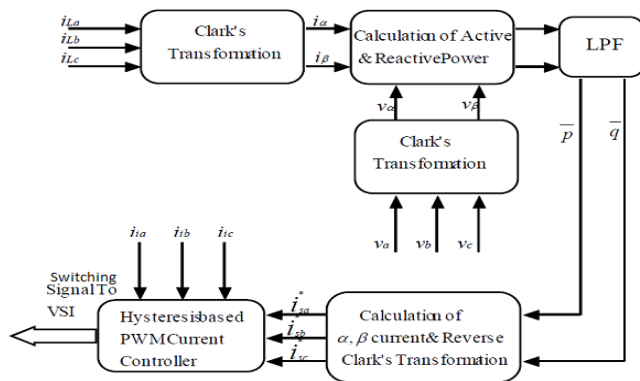

Figure 2. Instantaneous Reactive Power (IRP)

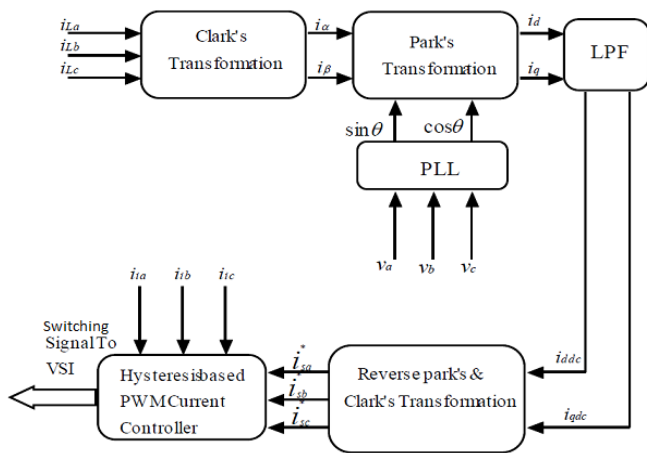

Figure 3. Synchronous Rotating Frame (SRF) Theory

V. RESULT AND DISCUSSION

Results according to TMS320LF28335 DSP pulse generator

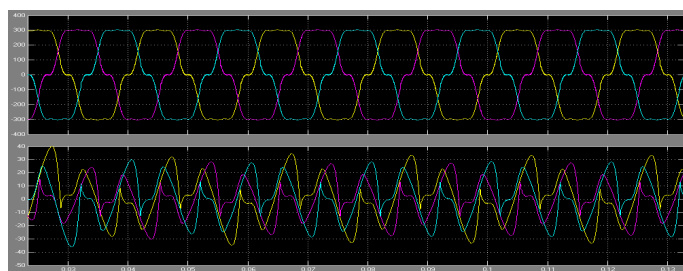

Figure 4. source voltage and current

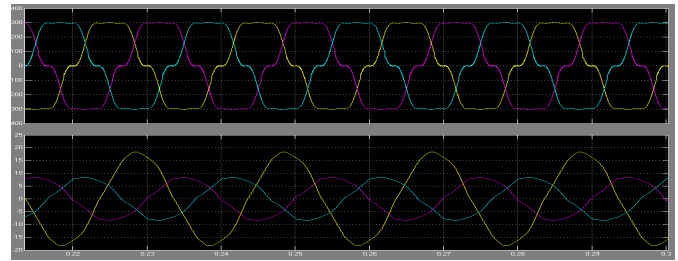

Figure 5. load voltage and current

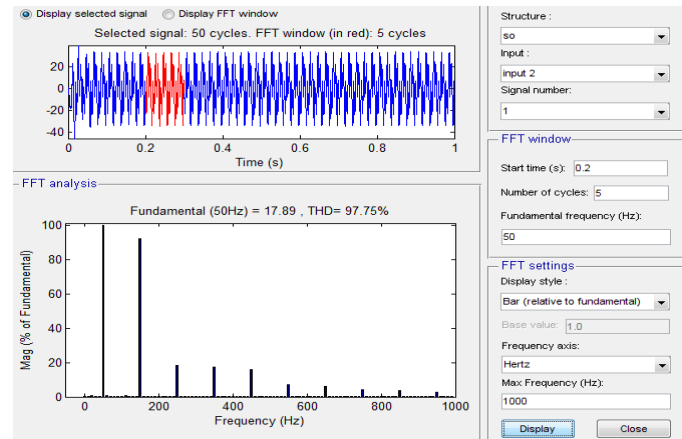

Figure 6. THD from source it is 97.75%

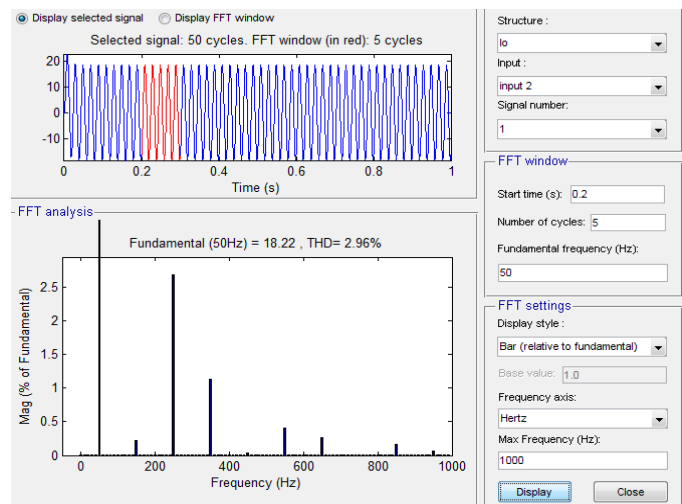

Figure 7. THD from load side it is 2.96%

VI. CONCLUSION

In this paper, reference current generation by using two different methods named as IRP and SRF has been proposed. The mathematical derivation of the IRP and SRF, theory has been employed to demonstrate the behavior of 3 LEG STACK CELL (STATCOM). Simulated results have verified the effectiveness of these control algorithms. The simulation results showed that the proposed control algorithm has good performance in the harmonic compensation and performance under distorted supply voltage condition.

VII. ACKNOWLEDGEMENT

I am greatly indebted forever to my Principal S.K BIRADAR and guide Mr. C.O. Reddy Asst. Prof. and head of Electrical Engineering Department, MSS'S College of Engineering and Technology, Jalna for his continuous encouragement, support, ideas, most constructive suggestions, valuable advice and confidence in me. He gave me complete freedom to pursue all my interests and also provided so many exciting directions to explore. Behind the freedom he gave, there is his strong belief that the best work is done.

REFERENCES

- [1] S.B. Bekiarov, A. Emadi, "Uninterruptible power supplies: classification, operation, dynamics, and control," Applied Power Electronics Conference and Exposition, vol. 1, pp. 597– 604, 2002.
- [2] R.A. Gannett, "Control strategies for high power four-Leg voltage source inverters," M.Sc. Dissertation, Virginia Polytechnic Institute, July 2001.
- [3] Motors and generators, NEMA Standards Publication no MG 1-1993.
- [4] IEEE Standard 100-1992, "IEEE Standard dictionary of electrical and electronic terms."