

A Numerical Study of Behaviour of Pile Foundation during Liquefaction of Soil

Nilesh C Kshirsagar¹, Prof. Girish Joshi²

^{1,2} Department of Structural Engineering

^{1,2} G.H.Raisoni College of Engineering, Wagholi, Pune, Savitribai Phule Pune University

Abstract- In modern construction, a piled-raft foundation is a composite construction which consists of piles and raft is one of the alternatives over conventional pile or raft foundations. It is used not only for reducing the settlement of soil, but also can handle large eccentric loading. The analysis of piled raft foundation is very tough and the design of piled raft with soil interaction effect is one of the major problem as the behavior of a structure is highly affected not only by the response of the superstructure, but also by the behavior of the foundation and the soil as well. In this study, the piled raft foundation is analyzed using ANSYS (3D analysis), a popular finite element software to study the load displacement response in a sand medium of various relative densities (loose, medium dense and dense) with interaction effects. Three different pile spacing - 3d, 4d and 5d were considered for the study (where d is the pile diameter) with three different pile configuration (3x3, 4x4 and 5x5) with an objective of finding the optimum number of piles and pile spacing for various relative densities of sand.

Keywords- Pile foundation, soil liquefaction, concrete pile, ANSYS (3D analysis).

I. INTRODUCTION

A. General

The piled raft foundation is a composite structure which consists of three bearing parts – the piles, mat and underground soil. The overall load from the superstructure is partly carried by the mat through the effect of subsoil and the remaining load only carried by the piles under the effect of negative skin friction. The pile raft foundation is mainly used to reduce the settlement – particularly the differential settlement. It is an economical design without affecting the safety criteria. The behavior of piled raft foundation mainly depends on the complex soil structure interaction effects and an understanding of these effects is necessary for the reliable design of such foundation. In a pile foundation the contribution of pile cap that functions as raft is completely neglected. It is used only for the supporting the structure. The piles alone carry the loads and transmit the load to the deep stratum. On the other hand, in a raft foundation the total building load is carried only by the raft demanding a very

thick raft, which thereby increases the cost of the foundation as well as it undergoes a large settlement. Structural failure by the formation of plastic hinges in piles passing through liquefiable soils has been observed in many of the recent strong earthquakes. It shows two such cases from past earthquakes. This suggests that the bending moments or shear forces that are experienced by the piles exceed those predicted by design methods (or codes of practice). All current design codes apparently provide a high margin of safety (using partial safety factors on load, material stress which increases the overall safety factor), yet occurrences of pile failure due to liquefaction are abundant. This implies that the actual moments or shear forces experienced by the pile are many times those predicted. It may be concluded that design methods may not be consistent with the physical mechanisms that govern the failure. The liquefaction is one of the challenging issues in geotechnical engineering and it damages structures and facilities during earthquakes. This phenomenon was reported as the main cause of damage to pile foundations during the major earthquakes (Kramer, 1996).

II. OBJECTIVE OF STUDY

- To study finite element modelling of pile foundation considering soil structure interaction.
- To model group of pile for 3d spacing, 4d spacing, 5d spacing for loose, medium, dense sand
- To study effect of pile cap during liquefaction
- To develop soil structure analytical model representing soil properties by spring-spot
- To study rate of settlement during liquefaction process in ANSYS to Study the linear static analysis of existing cooling towers and intermediate cooling towers or maximum principal stress with varying the height and thickness.

III. LITERATURE REVIEW

W. D. L. Finnanabuki Komuten And Kagawa University, Japan N. Fujita Anabuki Komuten and Kagawa University, Japan Behavior of Piles in Liquefiable Soils During Earthquakes: Analysis and Design Issues A general

picture of the current state of the art and the emerging technology for dealing effectively with the seismic design and analysis of pile foundations in liquefiable soils is presented. Two distinct design cases are considered and illustrated by case histories. One is the static response of pile foundations to the pressures and displacements caused by lateral spreading of liquefied ground. The other is the seismic response of piles to strong shaking accompanied by the development of high pore water pressures or liquefaction. Design for lateral spreading is examined in the context of developments in design practice and the findings from shake table and centrifuge tests. Response of piles to earthquake shaking in liquefiable soils is examined in the context of 1.5m cast in place reinforced concrete piles supporting a 14 storey apartment building.

NYSDOT (2015)" GEOTECHNICAL ENGINEERING MANUAL "A pile is a small diameter reinforced and grouted pile, constructed within a previously drilled borehole that provides axial capacity, or resistance, for a substructure. Unlike a driven pile, where each pile is a "tested" pile, the resulting axial capacity of each pile is not directly determinate unless a load test is performed on it. In addition, pile capacity is very sensitive to installation methods. Therefore, the role of the inspector is vital to ensure that the final product meets the expectations of the designer and the owner. Proper design and installation of piles is as much art as science, and their use should not be employed by the inexperienced. To understand pile installation techniques, a working knowledge of the methods and tools used by Contractors is essential, as well as an understanding of the effects that these have on the resulting performance of the pile. This manual is not intended or designed to certify or qualify an inspector to perform pile installation inspection. It is highly recommended that any inspector unfamiliar with pile construction take NHI course No. 132078 Pile Design and Construction.

HELIFIX (2015) "SUSTAINABLE STRUCTURAL SOLUTIONS" DIXIE MICRO-PILES providing structural support to stabilize foundations. Backed by considerable structural engineering experience and expertise, Helifix Dixie micro-piles provide a technically advanced solution to the problems of subsidence and foundation settlement. These innovatively designed pipe piles offer a far more cost effective and non-disruptive means of stabilization than traditional methods of major piling or mass underpinning.

ELARABI, H ET AL (2014) "Piles for Structural Support" Piles are generally classified firstly according to design application and grouting method. The design application dictates the function of pile while the grouting method defined the grout/ground bond capacity. In the design

application, there are two types of application. The first type is where the pile is directly loaded either axially or laterally and the pile reinforcement resists the majority of the applied load. This type of pile is used to transfer structural loads to deeper, more competent or stable stratum and may be used to restrict the movement of the failure plane in slopes. The loads are primarily resisted by the steel reinforcement structurally and by the grout/ground bond zone geotechnical. Second type of design application is where the pile reinforces the soil to make a reinforced soil composite that resist the applied load and known as reticulated pile network. This application of pile serves to circumscribe and internally strengthen the reinforced soil composite. The method of grouting is generally the most sensitive construction control over grout/ground bond capacity and varies directly with the grouting method. The second part of the pile classification is based primarily the method of placement and pressure under which grouting is used during construction.

G.L. SIVAKUMAR ET.AL (2004)"Bearing capacity improvement using pile" Piles are often used to improve the bearing capacity of the foundation against applied loading. In many cases, steel pipes of 50 to 200 mm diameters are used as piles. The strengthened ground acts as coherent mass and behaves remarkably well, capable of sustaining very high compressive loads at defined settlement or alternatively defined loads at reduced movement. Lizzi (1982) and Plumelle (1984) showed that piles create an in situ coherent composite reinforced soil system and the engineering behavior of pile-reinforced soil is highly dependent on the group and network effects that influence the overall resistance and shear strength of composite soil pile system. Juran et al. (1999) presented an excellent state of art review, covering all the studies and contributions, on the state of practice using piles. Considerable information on single pile design, evaluation of load bearing capacity, movement estimation models as well as effect of group and network effect have been covered in considerable detail. The authors also reviewed geotechnical design guidelines in different countries for axial, lateral load capacities and approach for movement estimation. SRIDHARAN ET AL (1993) described a case study in which a ten-storied building, originally in a precarious condition due to differential settlement, was restored to safety using piles. Galvanized steel pipes of 100 mm diameter and 10 m long with bottom end closed with shoe, driven at an angle of 60° with the horizontal were used and the friction between the pile and the soil was used as the design basis in evolving the remedial measures.

IV. SYSTEM DEVELOPMENT FOR SOIL STRUCTURE INTERACTION

Soil structure interaction plays an important role in the behavior of foundations. For structures like beams, piles, mat foundation and box cells it is very essential for consider the deformation characteristics of soil and flexural properties of foundations. It can be seen that when interaction is taken into account, the true design values arrived-at may be quite different from those worked out without considering interaction. In general in most of the case interaction causes reduction in critical design values of the shear and moments etc. However, there may be quite a few locations where the values show an increase. Because of these possibilities have their own roles to play in economy and safety of structure.

1. Methods of soil modeling-

The generalized stress-strain relations for soils, don't represent even the gross physical properties of a soil mass, the idealized models are observed to provide a useful description of certain features of soil media under limited boundary conditions. The idealized soil behavior particularly reduces the analytical rigor spent in the solution of complex problems in geotechnical engineering. The idealization will depend on a variety of factors such as:

- a) The type of soil.
- b) The soil conditions,
- c) The type of foundation,
- d) The nature of external loading,
- e) The method of construction,
- f) The purpose and life span of the structure and
- g) The economical considerations.

Some important idealized models of soil-foundation interaction are briefly presented in following articles. These surface deflection in-general represent the displacement characteristics of the soil-foundation interface, and form a significant part of the soil foundation interaction analysis.

2. The Winkler's Model:

Winkler assumed that the surface displacement of the soil medium at every point is directly proportional to the stress applied to it at that point and completely independent of stresses or displacement at other, even immediately neighboring point of the soil-foundation interface. Winkler's idealization of the soil medium can be physically represent as a system of closely spaced spring elements each of all will be deformed by the stress applied directly to it while the neighboring elements remains unaffected.

$$Q(x, y) = ky(x, y)$$

Where 'k' is termed as the modulus of sub grade reaction with unit of stress per unit length Equation is usually the response function or the kernel function for the Winkler's model. Physically, Winkler's idealization of the soil medium consists of a system of mutually independent spring elements with spring constant 'k'. One important feature of this soil model is that the displacement occurs immediately under the loaded area and outside the region the displacements are zero. See fig. Also, the displacements of a loaded region will be constant whether the soil is subjected to an infinitely rigid load or a uniform flexible load.

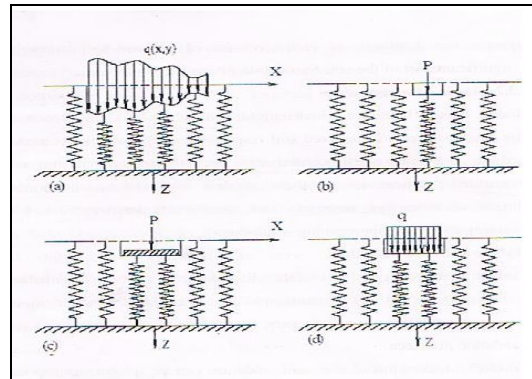

Figure 1. THE WINKLER'S MODEL

3. Elastic Half-space (Elastic continuum) Models:

In the case of in-situ surface deflections will occur certainly under and around the loaded region. Applicability of Winkler Model is only limited to such soil media, which possesses cohesion or transmissibility of applied forces The isotropic elastic continuum model can be effectively employed in the analytical treatment of soil-foundation interaction.

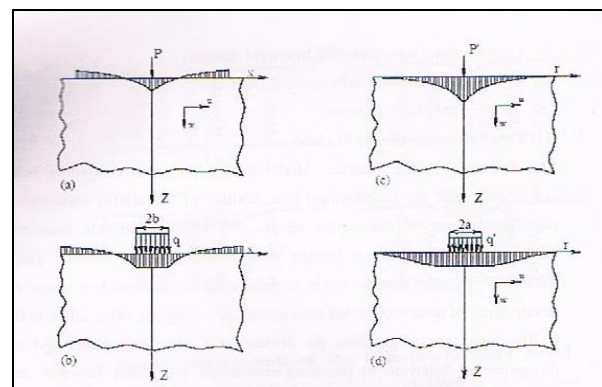

Figure 2. ELASTIC HALF-SPACE

Typical surface displacement profile of an elastic half-plane subjected to (a)A line load P, (b) A uniform load q of width 2b, (c) A concentrated P' , (d) A uniform load q' of radius 'a'.

V. PROBLEM STATEMENT

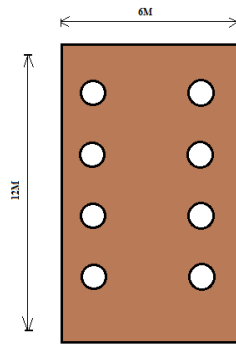

Figure 3. PILE FOUNDATION

- Diameter of pile = 1300mm,
- No of piles = 8
- Depth of pile cap =1500mm
- Dead weight of pier , pier cap and pile cap
- With 15% buoyancy =16250 KN
- With 100% buoyancy= 11200KN
- Dead weight of girder and footpath =1337.3KN
- Live load (two span loaded) = 3719.5KN
- (one span loaded) = 2052.7 KN
- Frictional force due to DL = 40 KN
- Moment = 949.5 KN
- Longitudinal force(for two span loaded)=688.8KN
- Moment= 688.8*23.677KNm
- For one span loaded=728.92KN
- Moment=728.92*23.677KNm

VI. FEA MODEL OF LIQUEFACTION OF PILE FOUNDATION IN ANSYS

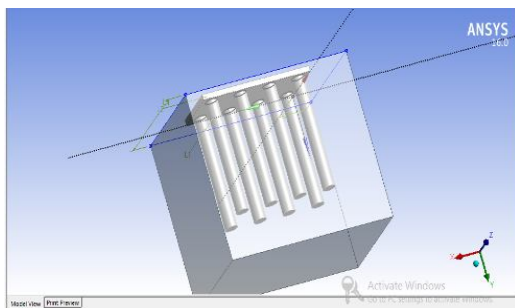

Figure 4. PILE FOUNDATION MODEL WITH SSI

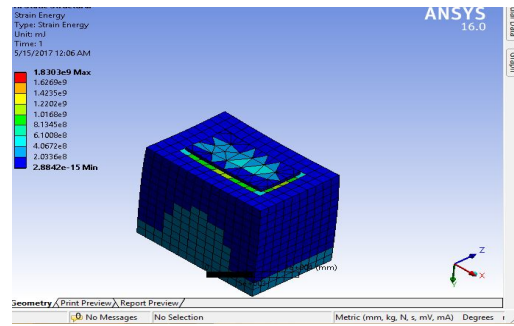

Figure 5. STRAIN ENERGY

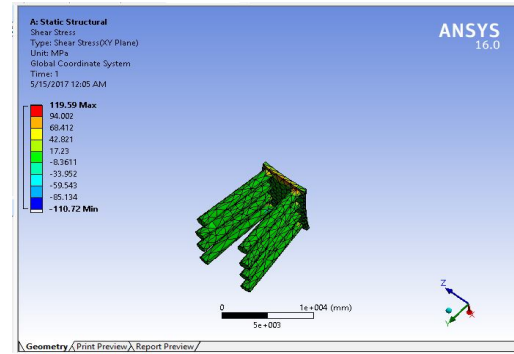

Figure 6. SHEAR STRESS

VII. RESULT AND CONCLUSION

1. Pile spacing affects greatly the maximum settlement, the ultimate settlement and the load carrying capacity of the piles during soil liquefaction.
2. In first stage from literature study it is concluded that the spacing between the piles should be within the permissible range that depend upon the loading conditions also.
3. If the load acts at the centre of the mat structure then we have to provide lesser pile spacing. Increasing the number of piles decreases the total and ultimate settlement and increases the load carrying capacity up to certain limit that depend upon the loading condition.
4. In later stage Pile cap and pile foundation is modelled with reference to Krishna bridge in ANSYS tool and deformation observed is 96mm during soil liquefaction.
5. In the first stage of study all IS 11841 code provision for design of NDCT is studied and finite element model in ANSYS is proposed against self-weight and lateral load against various dimensions. Following conclusions can be made after analysis.

VIII. ACKNOWLEDGEMENT

It give us immense pleasure to present this paper entitled “A Numerical Study of Behaviour of Pile Foundation

during Liquefaction of Soil”. I am very much thankful to Prof. Girish V. Joshi for his indispensable guidance, untimely support and encouragement through the course of this investigation, without which the preparation of this report would not be possible. Prof N.C Dubey, HOD, Civil Engineering Department, G.H.R.C.E.M for extending relevant facilities during this work. I am also thankful to all teaching and non-teaching staff members of civil engineering department. Lastly I also would like to thank my parents, friends and family members for their continuous support.

REFERENCES

- [1] W. D. L. FinnAnabuki Komuten and Kagawa University, Japan N. Fujita Anabuki Komuten and Kagawa University, Japan Behavior of Piles in Liquefiable Soils During Earthquakes.
- [2] NYSDOT (2015)" Geotechnical Engineering Manual A pile is a small diameter reinforced and grouted pile, constructed within a previously drilled borehole that provides axial capacity, or resistance, for a substructure.
- [3] Helifix (2015)"Sustainable Structural Solutions " Dixie Micro-piles providing structural support to stabilize foundations.
- [4] Elarabi, H et al (2014) “Piles for Structural Support .
- [5] G.L.Sivakumar et.al (2004) Bearing capacity improvement using pile.
- [6] Sridharan et al (1993) described a case study in which a ten-storied building, originally in a precarious condition due to differential settlement, was restored to safety using piles.
- [7] Loma Prieta 1990 yielded important observations on pile performance yielded important observations on pile performance.