

Load Flow Analysis And Optimal Allocation Of Distributed Generation Using PSAT

Prachi yaduvanshi¹, Ajit Singh Rajput²

¹M.Tech Scholar, Vikrant Institute of Technology and Management Gwalior

²Assistant Professor, Vikrant Institute of Technology and Management Gwalior

Abstract- Load-flow studies are very important aspect intended for planning future expansion of power systems as well as in determining the superlative operation of existing systems. With the help of load-flow study, one can attain the complete voltage angle and magnitude information's about each bus in a power system for identified load, real power and voltage conditions. But due to the increased demand of power other problems associated with load flow also arises such as voltage instability and overloading. So, there should be an optimal way to solve these problems and meet the requirement of Continuation Power Flow regarding improvement of voltage profile and reduction in power losses. This paper describes the optimal use of Distributed Generation for solving the load flow problems which improves voltage magnitude profile and reduces total losses in the line. This proposed approach will be tested on an IEEE 14 Bus test system using MATLAB Toolbox i.e. PSAT with or without using PV generator and the obtained simulated results are compared.

Keywords- Load Flow Analysis, Distributed Generation, CPF, PSAT.

I. INTRODUCTION

At present time, more than thousands of generating station and load centres is being interconnected through transmission lines to make power system a vast network. So, due to this very reason, the study or analysis of load flow is being required. A Load flow study is an analysis whose aim is to determine the magnitude and phase angles of current and voltage, reactive and real power flow in the transmission line under a normal condition in an active power system. Also voltages criteria and generator power in a power system. Once this data is collected then generator reactive power output as well as power flowing in every branch can easily be determined. Major tool (practically) is the voltage profile given by load flow. This tool will help to avoid big problems about power loss or failure also problem related to transmission of real and reactive power. Due to the increased demand of power other problems associated with load flow also arises such as voltage instability and overloading. So, there should be an optimal way to solve these problems and meet the requirement of Continuation Power Flow regarding improvement of voltage profile and reduction in power losses.

Many efficient load flow methods have been presented and practiced for a long time in the power system for solving the load flow problems. The well-known methods that are used are Newton-Raphson Method, Fast Decoupled Method, and Gauss-Seidel Method and so on. Among all these methods, Newton-Raphson Method is the most popular method used for load flow study. Basically, the use of Newton-Raphson method in the load flow problems is carried out because this is the best suited method for finding the critical bus voltage. For the optimal operation of the power system, improvement in the voltage magnitude profile and reduction in the power losses are very essential. Among all these methods, Distributed Generation is opted from the point of view of the optimal operation of the load flow analysis.

Distributed generation (or DG) can be defined in many ways but in general it bring up as a moderate (typically 1 kW – 50 MW) electric power generators which produces electricity next to a location which is nearby to the customers or we can say these are secured as an electric distribution system. Distributed generators comprises of: Synchronous generators, induction generators, reciprocating engines, micro turbines and so on. Distributed generator can be introduced into an electric power system for the improvement of the voltage magnitude profile and also reduces the total transmission losses in the power system.

In this paper, we propose an optimal Distributed Generation based approach for improving the voltage profile and reducing power losses in the system with the help of MATLAB software i.e. Power System Analysis Toolbox (PSAT) which is an open source MATLAB toolbox used in this paper for the simulation and analysis of an IEEE 14 Bus test system for solving load flow problems. Now days, PSAT is one of the most preferable software among various other software's such as MaTEMTP, Matpower, PAT, PST, SPS, VST etc. because it gives direct response to the load flow problems regarding critical voltage profile on the software.

II. POWER SYSTEM ANALYSIS TOOLBOX (PSAT)

Power System Analysis Toolbox (PSAT) project was first began by the Federico Milano in September, 2001. The

first public version of this software was out in November, 2002 and after that it has been freely access by any user for its use. PSAT is MATLAB based software used in the electric power system simulation and analysis. The command line version of the PSAT is based on the GNU Octave. The main purpose of the development of the PSAT is that there is a requirement of software for power system education that should be user-friendly, easy to use, and reliable and also allows users to draw single line diagrams, displaying results and plotting time domain graphs and simulations. PSAT leads as an improved version of the learning process for the students. Firstly, it appears as a user-friendly tool to the power system students as it is based on the MATAB. Further, the user or student implement the MATLAB algorithms and programs over PSAT and also modify it by adding more features to it.

PSAT offers power flow, continuation power flow, optimal power flow, and small-signal stability analysis and time domain simulation tools. In its simulation, it basically uses Newton Raphson solver having trapezoidal rule as integration method over most critical bus voltage profile. Now a day, PSAT is the mostly acceptable and used software among various software’s such as MatEMTP, Matpower, PAT, PST, SPS, and VST etc. because it offers various features rather than the other software’s like usual power flow (PF), continuation power flow and/or voltage security examination (CPF-VS), ideal power flow (OPF) , Small signal consistent quality examination (SSSA), time field re-enactment (TDS), graphical UI (GUI) and graphical system building (CAD).

This paper has presented PSAT used for the simulation of the load flow problems on an IEEE 14 Bus test system making use of the PV Generator or without using PV Generator for the graphical simulation over the critical bus. The results obtained from both the simulation are compared and the best results are chosen among them.

III. DISTRIBUTED GENERATION

Distributed Generation (DG) as any kind of electrical generator or static inverter which generates alternating current and having following features such as: It has the competency for parallel operation with the utility distribution system. It has the capability to function individually from the utility system and also feed a load which can be fed by the utility electrical system. Sometimes it referred as a “generator”.

Distributed generator can be introduced into an electric power system for the improvement of the voltage magnitude profile and also reduces the total transmission losses in the power system. When the Distributed generators are

connected to the power system grid, it affects the various profiles of the system such as the voltage regulation, sustained interruptions, harmonics, sags, swells, etc. Along with the different features, DG comprises of an often function in which it make use of the surplus heat from the generation method as an further form of energy for space heating, process heating, dehumidification and also for cooling over absorption refrigeration.

In this paper, Distributed Generation plays an important role in improving the voltage magnitude profile and reducing the power losses in the system with the help of PV Generator. A PV Generator is a part of Distributed Generation which is connected over the most critical bus on an IEEE 14 Bus test system for improving the voltage magnitude profile and the results are simulated with the help of open source toolbox provided by the MATLAB i.e. PSAT. The simulation of the 14 bus system over critical bus is done with or without using the PV Generator and the obtained results are compared thereafter.

Frequency Base (Hz)	50
Power Base (MVA)	100
Starting Time (s)	0
Ending Time (s)	20
PF Tolerance	1e-05
Max. PF Iteration	20
Dynamic Tolerance	1e-05
Max. Dynamic Iteration	20

Table 1: System Parameters

The single line diagram of an IEEE 14 Bus test system in PSAT is shown below:

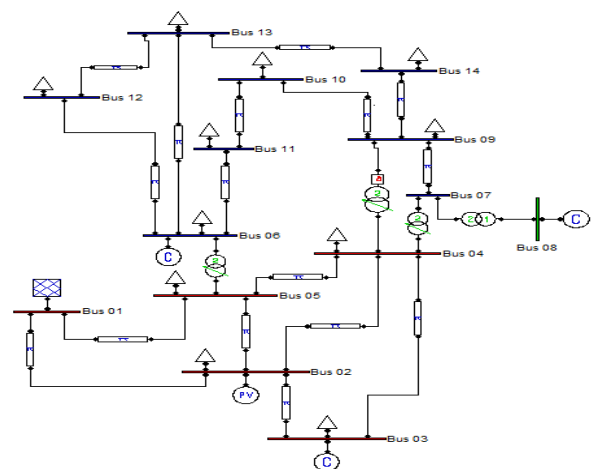

Fig.1: IEEE 14 Bus test system in PSAT

IV. SIMULATION AND RESULTS

This paper describes the modelling of an IEEE 14 bus test system by using PSAT. The problems with the load flow analysis are improved here by using the approach of optimal Distributed Generation. The most critical bus is identified and results obtained with or without using PV Generator are compared for improving voltage magnitude profile and reducing the total power losses in the line.

Results without using PV Generator are shown below:

After the simulation of 14 bus test system in PSAT software, the simulated result is shown above in the figure which shows that the voltage magnitude profile at the bus number 8 is very critical because according to the software predetermined limits if any bus crosses the limit i.e. 1.06 then it is taken as a critical or weak bus

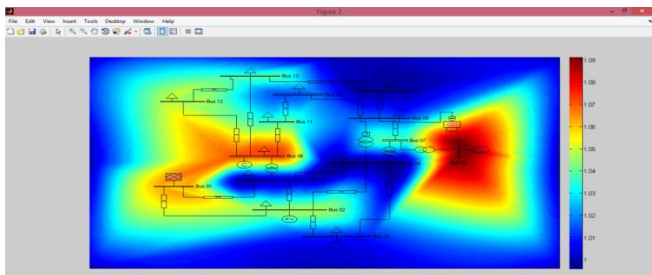

Fig.2: Simulation result of 14 bus system in PSAT for weak bus determination

Power flow using Newton-Raphson Method at each bus before connecting PV Generator at critical bus:

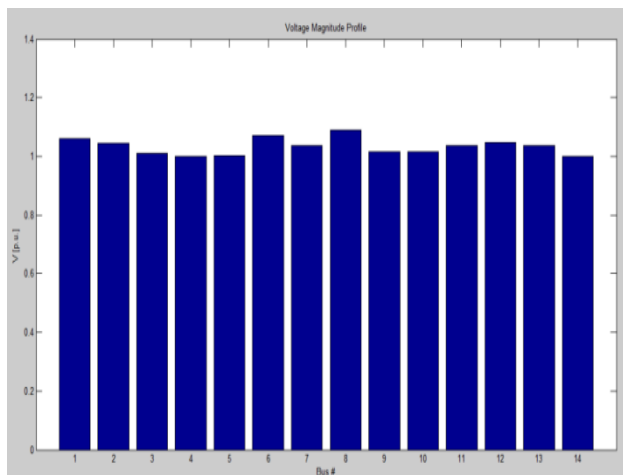

Fig.3: Simulation results of Voltage Profile at each bus without using PV Generator in PSAT

Fig.3 shows per unit voltages at different buses without connecting the PV Generator using Power flow with NR Method.

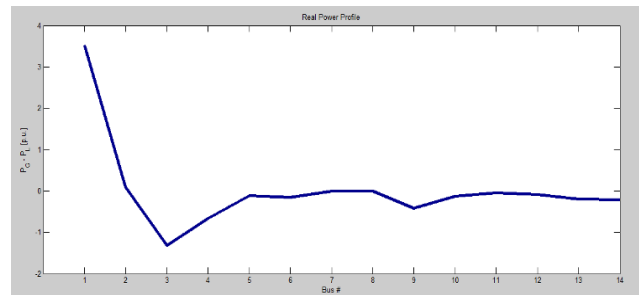

Fig.4: Simulation results of Real Power at each bus without using PV Generator in PSAT

Fig.4 shows per unit Real Power at different buses without connecting the PV Generator using Power flow with NR Method.

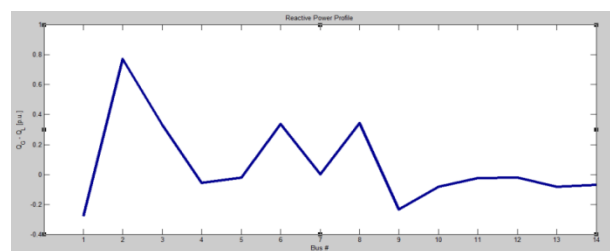

Fig.5: Simulation results of Reactive Power at each bus without using PV Generator in PSAT

Fig.5 shows per unit Real Power at different buses without connecting the PV Generator using Power flow with NR Method.

Results by using PV Generator are shown below:

Power flow using the NR Method at each bus after connecting PV Generator:

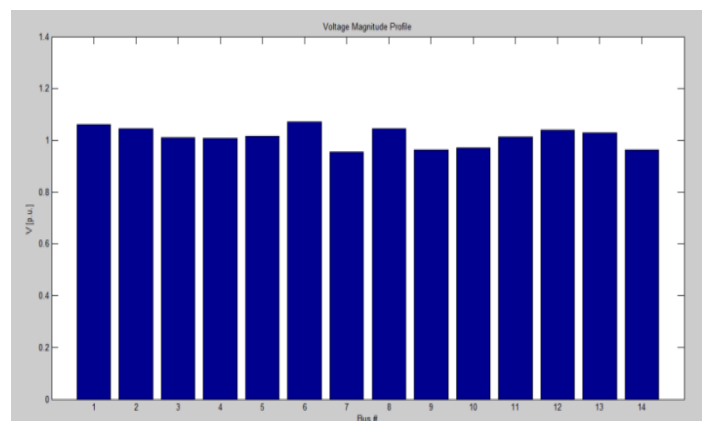

Fig.6: Simulation results of Voltage Profile at each bus using PV Generator in PSAT

Fig.6 shows per unit voltages at different buses after connecting the PV Generator using power flow with NR Method

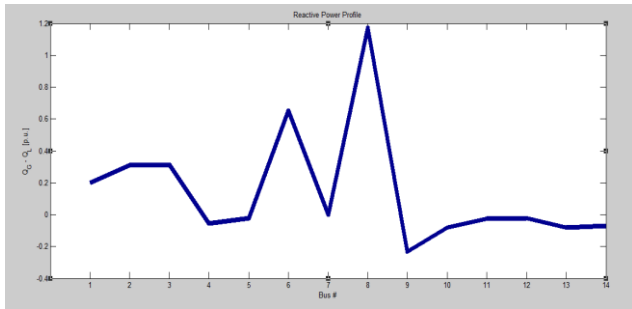

Fig.7: Simulation results of Real Power at each bus using PV Generator in PSAT

Fig.7 shows per unit Real Power at different buses after connecting the PV Generator using Power flow with NR Method.

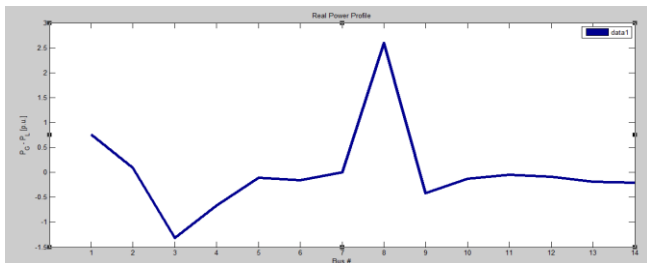

Fig.8: Simulation results of Reactive Power at each bus using PV Generator in PSAT

Fig.8 shows per unit Real Power at different buses after connecting the PV Generator using Power flow with NR Method.

Table 2 shows the values of voltage magnitude, phase angles, total generated Real Power and Reactive Power and total load connected to the system

Bus	V	Phase	P gen	Q gen	P load	Q load
	[p.u.]	[rad]	[p.u.]	[p.u.]	[p.u.]	[p.u.]
Bus 01	1.06	0	0.758019	0.199072	0	0
Bus 02	1.045	-0.03015	0.4	0.486771	0.3038	0.1778
Bus 03	1.01	-0.15191	8.88E-16	0.578051	1.3188	0.266
Bus 04	1.006801	-0.01575	1.2E-14	-4.6E-15	0.6692	0.056
Bus 05	1.015468	-0.02578	4.58E-15	5.82E-15	0.1064	0.0224
Bus 06	1.07	-0.07871	1.69E-15	0.756673	0.1568	0.105
Bus 07	0.954282	0.248121	-1.9E-14	3.02E-14	0	0
Bus 08	1.045	0.725289	2.6	1.17054	0	0
Bus 09	0.96286	0.082775	1.57E-14	7.66E-15	0.413	0.2324
Bus 10	0.970038	0.045054	4.19E-15	8.88E-16	0.126	0.0812
Bus 11	1.013469	-0.02074	1.82E-15	1.01E-15	0.049	0.0252
Bus 12	1.040205	-0.08997	-6.2E-16	-1.1E-15	0.0854	0.0224
Bus 13	1.029044	-0.07856	5.55E-16	-2.2E-15	0.189	0.0812
Bus 14	0.961867	-0.0178	3.41E-15	-2.4E-15	0.2086	0.07

Table 3: Power Flow using NR method having trapezoidalruleas Integration Method with PV Generator

Table 3 shows the values of voltage magnitude, phase angles, total generated Real Power and Reactive Power and total load connected to the system.

Comparison of the simulated results obtained for an IEEE 14 bus test system in PSAT with or without Solar PV Generator:

The results obtained from both the conditions conveyed that by using PV Generator in the system improves the voltage magnitude profile on the critical bus and also reduces the total losses. The compared results for the same are shown below in the table 4.

Bus	V	Phase	P gen	Q gen	P load	Q load
	[p.u.]	[rad]	[p.u.]	[p.u.]	[p.u.]	[p.u.]
Bus 01	1.06	0	3.520522998	-0.27899	0	0
Bus 02	1.045	-0.1355	0.4	0.95134	0.3038	0.1778
Bus 03	1.01	-0.33145	2.22045E-15	0.59796	1.3188	0.266
Bus 04	0.99858	-0.26363	2.39808E-14	4E-15	0.6692	0.056
Bus 05	1.00293	-0.22745	-5.82867E-16	4.4E-14	0.1064	0.0224
Bus 06	1.07	-0.37854	8.49321E-15	0.44264	0.1568	0.105
Bus 07	1.03738	-0.35426	-1.08708E-15	2.4E-15	0	0
Bus 08	1.09	-0.35426	4.57967E-16	0.34242	0	0
Bus 09	1.01648	-0.4021	-1.04361E-14	3.6E-15	0.413	0.2324
Bus 10	1.01501	-0.40495	2.47025E-15	2.9E-15	0.126	0.0812
Bus 11	1.03692	-0.39461	3.95517E-15	-4.2E-16	0.049	0.0252
Bus 12	1.04652	-0.40045	-9.15934E-16	-1E-15	0.0854	0.0224
Bus 13	1.03697	-0.40236	1.63758E-15	3E-15	0.189	0.0812
Bus 14	0.99917	-0.42813	2.55351E-15	-3.7E-16	0.2086	0.07

Table 2: Power Flow using NR Method having trapezoidal rule as Integration Method without PV Generator

	Real Power (p.u.) without PV generator	Reactive Power (p.u.) without PV generator	Real Power (p.u.) with PV generator	Reactive Power (p.u.) with PV generator
Total Generation	3.9205	2.0553	3.7580	3.1911
Total Load	3.626	1.1396	3.626	1.1396
Total Losses	0.2945	0.9157	0.1320	2.0515

V. CONCLUSION

This paper illustrated the optimal Distributed Generation based approach for the analysis of load flow problems by using Newton-Raphson Solver with the help of MATLAB based software i.e. Power System Analysis Toolbox (PSAT) which is an open source toolbox used for the simulation and analysis of an IEEE 14 Bus test system. A PV Generator is

a part of Distributed Generation which is connected over the most critical bus on a 14 Bus test system for improving the voltage magnitude profile and reducing the total losses in the system. The simulation of the 14 bus system over critical bus is done with or without using the PV Generator and the obtained results are compared thereafter. So, basically what we get is? The voltage profile is improved at critical bus i.e. bus number 8 and the active power losses are also improved up to 44.8% in comparison of without using PV Generator.

REFERENCES

- [1] DivyaAsija, PallaviChoudekar, K.M.Soni, S.K. Sinha, "Power Flow Study and Contingency status of WSCC 9 Bus Test System using MATLAB", International Conference on Recent Developments in Control, Automation and Power Engineering (RDCAPE), pp. 338-342, March, 2015.
- [2] L. Vanfretti, F. Milano, "Application of the PSAT, an Open Source Software, for Educational and Research Purposes", pp. 1-7, 2007.
- [3] Federico Milano, Power System Analysis Toolbox Quick Reference Manual for PSAT, version 2.1.2, June 26, 2008.
- [4] Umar Naseem Khan, "Distributed Generation and Power Quality".
- [5] Guido Pepermans, Driesen J., Dries Haeseldonckx, Ronnie Belmans, William D'haeseleer, "Distributed Generation: Definition, Benefits and Issues", pp. 2-20, August 2003.
- [6] Thomas Ackermann, Göran Andersson, Lennart Söder, "Distributed generation: a definition", Electric Power Systems Research, pp. 196-204, December 2000.
- [7] Chongru Liu, Anjan Bose, Fellow, Minxiao Han and Xiuyu Chen, "Improved Continuation Power Flow Method for AC/DC Power System", IEEE Electrical Power and Energy Conference, pp. 192-198, 2011.
- [8] Ping Yan and Arun Sekar, "Study of Linear Models in Steady State Load Flow Analysis of Power Systems", Member, IEEE, pp. 666-671, 2002.
- [9] El Fadil Zakaria, Kamal Ramadan and Dalia Eltigani, "Method of Computing Maximum Loadability, Using Continuation Power Flow", International Conference on Computing, Electrical and Electronic Engineering (ICCEEE), pp. 663-667, 2013.
- [10] Mohamed E. El-Hawary, "Introduction to Electrical Power Systems", IEEE Press Series on Power Engineering, Series Editor, A John Wiley & Sons, INC., Publication.
- [11] P. S. Bhowmik, D. V. Rajan, S. P. Bose, "Load Flow Analysis: An Overview", International Journal of Electrical, Computer, Energetic, Electronic and Communication Engineering, Vol: 6, No: 3, pp. 263-268, 2012.
- [12] PrabhaKundur, "Power System voltage stability and Control", McGraw- Hill.
- [13] Carson W. Taylor, "Power System voltage stability and Control", McGraw-Hill, Inc. 1993.
- [14] An Open Source Power System Analysis Toolbox, Federico Milano, Member, IEEE.
- [15] F. Milano, "Power System Analysis Toolbox Documentation for PSAT version 2.0.0", February 14, 2008.