

Accelerometer Based Wireless Mouse using Arduino Board

Prof.M.M.Maindarkar¹, Kamthe Netra², Keerthana Reddy³

^{1,2,3} E&Tc Dept.

¹ JSPM'S ICOER Wagholi

^{2,3} SPPU university PUNE

Abstract- With the day to day advance able in technology the interaction between the human and the computer is taper. As there is more and improvement in the mobile technology from button keypads to touch screens. As the current PCs need a pad to operate its mouse and are wired most of the time. Our motto is to develop a wireless mouse which works on the hand gestures of the user without the need of a pad which makes an effortless interaction between the human and the computer. The implementation is done using sensor named accelerometer. To sense the hand gesture. Accelerometer is a motion sensor which sense changes in the motion in any of the hand gestures. In this project the accelerometer will be at the user side, attached to the hand to sense the movement and the output is provided to a controller to process it. Further modification are done by the controller to the values and the transmitter through a Wi-Fi module to the PC. At the receiving end a mouse control program which contains function to control the mouse reads these values and performs necessary actions.

Keywords- Accelerometer, WiFi, module, Arduino Leonardo

I. INTRODUCTION

Today's digitized world, processing speed increased dramatically, with computers being advanced to the levels where they can assist humans in complex tasks. Yet, input technologies seem to cause a major bottleneck in performing some of the tasks, underutilizing the available resources restricting the expressiveness of application use. The very basis of mouse device involves a pointing device that works on supporting surface by detecting two dimensional motion related to it.[10]

In today's world optical mouse has a limited range they work within the length of their connecting cable and require a surface to work on HUMAN COMPUTING INTERACTION(HCI) is one of the important area of research where people try to improve the computer technology. Gesture is a very natural human communication capability. HID is a key area in a modern electronics era .

Gesture recognition can be introduced in modern day computers to play 3-Dgames.Simple inertial navigation sensor like accelerometer can be utilized in getting dynamic or static acceleration profile of moment to move cursor of mouse or gyroscope to even rotate 3D object.

The proposed system uses accelerometer sensor arduino Leonardo board Wi-Fi module pc program interface etc. to design an accelerometer based wireless mouse using arduino board. The Proposed wireless mouse with the features of switch and control, zoom in zoom out, left and right click.

II. LITERATURE SURVEY

Optical mouse have a limited range. They work within the length of their connecting cable and require a surface to work on. Even In the case of a wireless mouse the requirement of a surface is still present. So the fact that it is wireless in not of much use other than allowing for a desktop with fewer wires attached. HUMAN COMPUTING INTERACTION (HCI) is one of the important area of research were people try to improve the computer technology. Gesture is a very natural human communication capability. A distinguishing feature of the gesture communication channel is that it allows one to act on one's environment as well as to retrieve information from it. It is already common to interact with a new class of devices entirely by using natural gestures. The idea that natural, comfortable motions can be used to control computers is opening the way to a host of the input devices that look and feel very different from the keyboard and mouse. Simple inertial navigation sensor like accelerometer can be utilized in getting Dynamic or Static acceleration profile of movement to move cursor of mouse or Gyroscope to even rotate 3-D object. The advancement of technology in the field of sensors made it possible to design a humanoid for any application. Efforts are being made to reduce the gap between a human and a machine.

III. BLOCK DIAGRAM

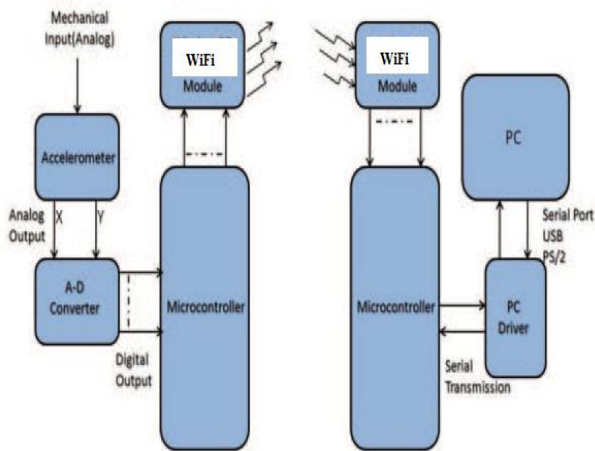

Figure 1. Block diagram[3]

The basic blocks of accelerometer based wireless mouse using arduino board is shown below. The block diagram consist of accelerometer, Wi-Fi module, arduino Leonardo board. The arduino Leonardo board behave as a USB human interface devices. The transmitter and receiver sections are connected with Wi-Fi module. The motions of hands will get detected by accelerometer sensor and processed to transmitter section arduino board which is program to execute the required task of transferring the data to receiver section to implement the required function of wireless mouse. [3]

Arduino is an open soure hardware and software platform for making interactive projects that can sense and control the physical world [11]. The transmitter and receiver sections are connected via WiFi module ESP8266. ESP8266 is a complete and self-contained Wi-Fi network solutions that can carry software applications, or through another application processor uninstal all Wi-Fi networking capabilities.

The accelerometer senses the change in motion that is the tilt of the hand. The analog output of the accelerometer sensor is given to three analog inputs of the Arduino board. The inbuilt ADC of the board converts the values to digital and sends the data to the Wireless module through Serial UART port. The change in the acceleration values of the accelerometer are transmitted to the PC, where in the software applications take control and moves the mouse cursor. The Air mouse is design to execute the functions such as switch and control. Left and Right Click, zoom in and zoom out etc.

IV. RESULTS

This paper presents The Accelerometer based Wireless Mouse using arduino Micro-controller Board. In this we have started with the understanding the basics of

accelerometer, learning arduino Leonardo microcontroller basics and programming. To program the controller to design a wireless mouse to execute the wireless mouse functions such as switch and control, left and right click as well as zoom in and zoom out. The mouse is execute these four functions with better accuracy and cover large area of mouse coverage.

V. CONCLUSION

Accelerometer based Wireless Mouse using Aurdino Board is completed. An accelerometer is used to sense motion, more particularly acceleration in a given direction. Accelerometer sis used as a motion sensor with three axes of the accelerometer that is the X-axis and Y-axis, which forms a plane of motion, are used to sense the tilt in the specific direction and the mouse cursor is moved accordingly. Change of acceleration or a tilt in the direction of Z-axis, is used for click and release of the cursor of mouse. The analog output of the accelerometer sensor is given to three analog inputs of the arduino board. The inbuilt ADC of the board converts the values to digital and sends the data to the Wireless module through Serial UART port. In the proposed system, the cursor is made to move based on the tilt of the accelerometer, not exactly the position. This is a tilt based approach. The position based approach can be tried in the future, where in the mouse cursor just follows the movement of the finger.

VI. ACKNOWLEDGMENT

We are pleased to acknowledge many individuals for their invaluable guidance during the course of this project work. It is our great pleasure to express our heart full gratitude towards all of them.

We would like to acknowledge the foremost gratitude and deep appreciation to our internal Project Guide Prof. N.S.LABHADE for his valuable advice, guidance, encouragement and support for project, who continuously helped us throughout the project and without her guidance, this project would have been an uphill task.

We extend our sincere thanks to our H.O.D Prof.S.L.LAHUDKAR for giving us motivation and consistent support.

We are also great full to all the teaching and non-teaching staff of our department who co-operated with us regarding some issues.

Lastly we would like to thank our Principal Dr. D.D.SHAH & all the people who had directly or indirectly

helped and co-operated with us nicely for the smooth development of this project.

REFERENCES

- [1] Barrett, S. "Arduino Microcontroller Processing for Everyone!" Synthesis Lectures on Digital Circuits and Systems, 2013.
- [2] Badamasi, Y.A. "The working principle of an Arduino" Electronics, Computer and Computation (ICECCO), 11th International IEEE Conference, 2014.
- [3] <http://ieeexplore.ieee.org/document/7342681/?denied>
- [4] <https://www.arduino.cc/en/main/arduinoboardleonardo>
- [5] <https://nurdspace.nl/ESP8266>
- [6] <https://www.sparkfun.com/products/13678>
- [7] <https://m.youtube.com/watch?v=dSKZw5y5Q8w>
- [8] <https://www.accelerometer.com>
- [9] <http://www.ijert.org/wirelessmouseusingarduino>
- [10] R. Sathyaleena , D. Sobitha , B.Pradeeppraja, "an overview of wireless mouse:history, challenges and applications",International Journal of engineering