

Smart Home Automation

Poonam Kasre¹, Preeti Kumbhar², Snehal Tilekar³, Deepali Yewale⁴

^{1,2,3,4} Electronics And Telecommunication Department

^{1,2,3,4} Savitribai Phule Pune University, Aisssms Ioit Kennedy Road, Pune 411001, India

Abstract- In today's lifestyle home automation is playing a vital role. The use of home automation is increasing day by day. The various technologies are used for home automation such as GSM, Bluetooth, WIFI, IOT etc. The control of home appliances like fan, lights, TV, A/C etc. is possible from anywhere and anytime due to this it is widely used throughout the world. We have used GSM technology for outdoor control and Bluetooth module for indoor control. This system is useful for handicapped and old aged people. For security purpose gas leakage detector and Finger print sensor is used.

Keywords- GSM, Finger print sensor, Arduino mega 2560, SMS, Bluetooth.

I. INTRODUCTION

Home automation is one among the different types of automation; Home automation refers to the use of computer and information technology to control home appliances. Systems can range from simple control of lighting to microcontroller based network. The Electrical Home appliances concept was introduced in between 1915 and 1920 but in 1960 actual integrated smart home concept was built up by some hobbyist. The first company to develop the products made for smart automated homes was General Electric Company. Now-a-days lots of research are going on in this home automation subject.

In this paper we have discussed the controlling of home appliances using GSM and Bluetooth technologies. We can control home appliances from outside the house by sending just one SMS (short message system) using GSM technology. And using Bluetooth we can control from inside the house. Finger print sensor as well as Gas leakage detector is used for security. If there is any leakage of gas found then system will send message to mobile phone.

II. WORKING PRINCIPLE

The proposed system is worked in two systems.

1. Bluetooth controlled system
2. GSM controlled system

1. Bluetooth controlled system

- When switch is pressed finger print sensor gets activated. Finger print sensor is used for security.
- Finger print sensor starts scanning the fingerprints; if it is matched with predefined fingerprints then Bluetooth module gets activated.
- Pair the Bluetooth module with our mobile phone once it gets activated.
- Send the commands using Bluetooth terminal HC-05 Android App. Accordingly status of load will change.

2. GSM controlled system

- When switch is off GSM module as well as gas detector gets activated.
- After activation of GSM send the SMS to control the loads.
- If any leakage of gas is detected by sensor it will inform user by sending SMS.

III. PROPOSED SYSTEM

A. BLOCK DIAGRAM

The block diagram of our proposed system is given in fig (a). It basically consists of three sections that are input section, controller section and output section. In input section we have Bluetooth module, GSM module, Gas detector and Finger print sensor. All this modules gives its output to controller for processing. Here we have used Arduino Mega 2560 microcontroller. The controller is used to process the data or information received from input modules. After processing it will send some commands to output section. The output section contains Relay Board, devices like Bulb and motor. These devices will activate as per commands send by microcontroller.

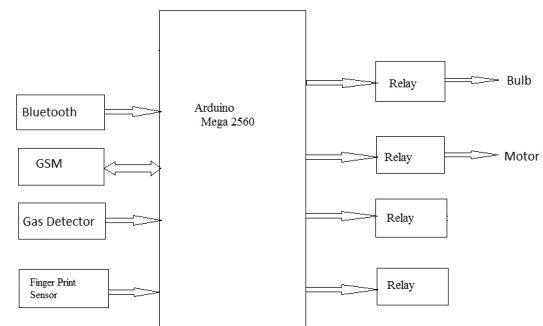

Figure 1.

Bluetooth Module



Figure 2.

Bluetooth is a wireless technology standard for exchanging data over short distances (using short-wavelength UHF radio waves in the ISM band from 2.4 to 2.485 GHz) from fixed and mobile devices and building personal area networks (PANs). Invented by telecom vendor Ericsson in 1994, it was originally conceived as a wireless alternative to RS-232 data cables. It can connect several devices, overcoming problems of synchronization.

Bluetooth is managed by the Bluetooth Special Interest Group (SIG), which has more than 25,000 member companies in the areas of telecommunication, computing, networking, and consumer electronics. The IEEE standardized Bluetooth as IEEE 802.15.1, but no longer maintains the standard. The Bluetooth SIG oversees development of the specification, manages the qualification program, and protects the trademarks. A manufacturer must make a device meet Bluetooth SIG standards to market it as Bluetooth device.

GSM Module



Figure 3.

GSM (Global System for Mobile Communications), is a standard developed by the European Telecommunications Standards Institute (ETSI) to describe the protocols for second-generation (2G) digital cellular networks used by mobile phones, first deployed in Finland in July 1991.[2] As of 2014 it has become the de facto global standard for mobile communications – with over 90% market share, operating in over 219 countries and territories.[3]

2G networks developed as a replacement for first generation (1G) analog cellular networks, and the GSM standard originally described a digital, circuit-switched network optimized for full duplex voice telephony. This expanded over time to include data communications, first by circuit-switched transport, then by packet data transport via GPRS (General Packet Radio Services) and EDGE (Enhanced Data rates for GSM Evolution or EGPRS).

Subsequently, the 3GPP developed third-generation (3G) UMTS standards followed by fourth-generation (4G) LTE Advanced standards, which do not form part of the ETSI GSM standard.

"GSM" is a trademark owned by the GSM Association. It may also refer to the (initially) most common voice codec used, Full Rate.

FINGER PRINT SENSOR



Figure 4.

Optical fingerprint sensor will make adding fingerprint detection and verification super simple. These modules are typically used in safes - there's a high powered DSP chip that does the image rendering, calculation, feature-finding and searching. Connect to any microcontroller or system with TTL serial, and send packets of data to take photos, detect prints, hash and search. You can also enroll new fingers directly - up to 162 finger prints can be stored in the onboard FLASH memory.

ARDUINO MEGA 2560

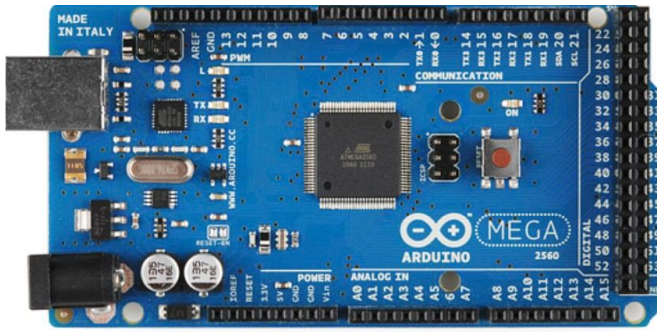

Figure 5.

The Mega 2560 is a microcontroller board based on the ATmega2560. It has 54 digital input/output pins (of which 15 can be used as PWM outputs), 16 analog inputs, 4 UARTs (hardware serial ports), a 16 MHz crystal oscillator, a USB connection, a power jack, an ICSP header, and a reset button. It contains everything needed to support the microcontroller; simply connect it to a computer with a USB cable or power it with an AC-to-DC adapter or battery to get started. The Mega 2560 board is compatible with most shields designed for the Uno and the former boards Duemilanove or Diecimila.

IV. RESULTS

[1] After sending command through Bluetooth and GSM module to turn on the devices we get this output.

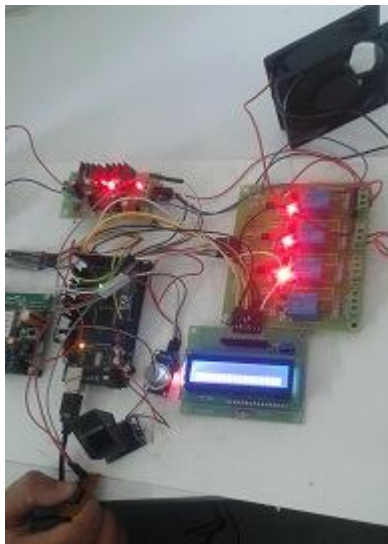

Figure 6.

[2] [2]After sending command through Bluetooth and GSM module to turn off the devices we get this output.

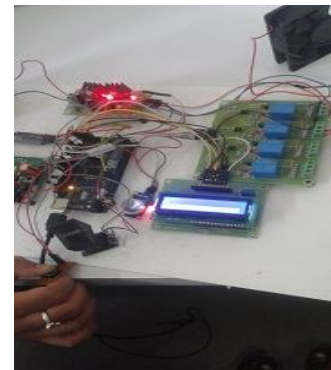

Figure 7.

[3] [3]When gas is detected by the gas sensor we get the SMS as

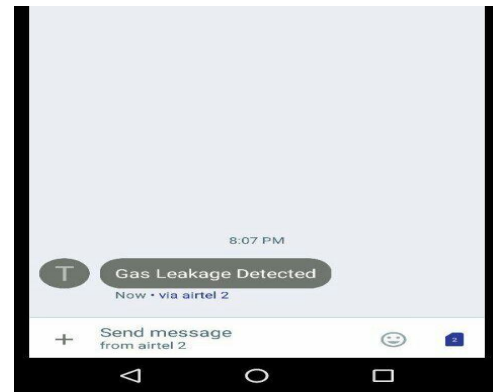

Figure 8.

V. CONCLUSION

The home automation system has been experimentally proven to work satisfactorily by connecting sample appliances to it and the appliances were successfully controlled from a wireless mobile device. The Bluetooth client was successfully tested on a multitude of different mobile phones from different manufacturers, thus proving its portability and wide compatibility.

This project will not only provide convenience to the common man but will be a boon for the elderly and disabled.

REFERENCES

[1] Smart GSM Based Home Automation SystemRozita Teymourzadeh, CEng, Member IEEE/IET, Salah Addin Ahmed, Kok Wai Chan, and Mok Vee Hoong Faculty of Engineering, Technology & Built Environment <http://doi.org/10.1016/j.rcim.2008.02.007>

[2] Microcontroller Based Home Security and Load Controlling Using Gsm Technology I. J. Computer Network and Information Security, 2015, 4, 29-36

Published Online March 2015 in MECS.

- [3] Microcontroller Based Home Security System with GSM Technology, Open Journal of Safety Science and Technology, 2015, 5, 55-62 Published Online June 2015 in SciRes.
- [4] A Review Paper on Smart GSM Based Home Automation System, Pawan Singh¹, Krupa Chotalia², Sanket Pingale³, Sandhya Kadam International Research Journal of Engineering and Technology (IRJET)
- [5] Home Automation & Security System Using Arduino Android ADK, P Pavan Kumar¹, G Tirumala Vasu, International Journal of Emerging Trends in Engineering Research (IJETER), Vol. 3 No.6.
- [6] GSM Based Home Automation, Safety and Security System Using Android Mobile Phone,
- [7] Akanksha Singh, Arijit Pal, International Journal of Engineering Research & Technology (IJERT)