

# Solar Powered Hybrid Inverter with Battery Backup

Mr. Jayant Thadani<sup>1</sup>, Dr. P. M. Daigavane<sup>2</sup>, Dr. D. R. Tutakne<sup>3</sup>

Department of Electrical Engineering

<sup>1, 2, 3</sup> G. H. Raisoni College of Engineering, Nagpur, India

**Abstract-** A three level two switch Inverter with step up transformer and a suitable LC component system is employed. The output of this scheme is in quasi square wave form, which is then converted to regulated Sine wave output by use of LC component. The system will be able to power the load demand and in case of excess availability of power than required, the power can be fed to the grid with synchronization and phase angle control. A leading phase angle is maintained depending upon the quantity of power desired to be fed to the grid. In case of unavailability of excess of Solar energy, no phase angle difference is maintained thus isolating the flow of power to the grid.

**Keywords-** Sine wave output, grid synchronization, phase angle control, 3 level Inverter

## I. INTRODUCTION

In current global energy scenario, renewable energy sources play an important role in meeting the ever-increasing energy demand. Solar photo-voltaic system is a popular solution as Solar energy is abundantly available. The power output from the solar panels depends on continuously varying solar IR radiation level and temperature. Hence Battery as a backup, acts as a stiff Voltage source ensuring continuity of supply and maximum power absorption from Solar source. The proposed scheme presents a Hybrid scheme which combines the benefits of conventional system and Renewable Solar power thus providing economic and simple solution. The scheme has a major advantage of supplying the load irrespective of simultaneous availability of grid and Solar power thus eliminating the disadvantage of the present conventional system. Hence, a techno-commercial residential rooftop model can be installed as an efficient, reliable and economic solution with an added advantage of utilizing the Solar power 24x7.

## II. PROPOSED SCHEME

The scheme represents the block diagram of the proposed scheme, which shows the control circuit and the power circuit scheme suitably designed for implementation and to obtain desired results.

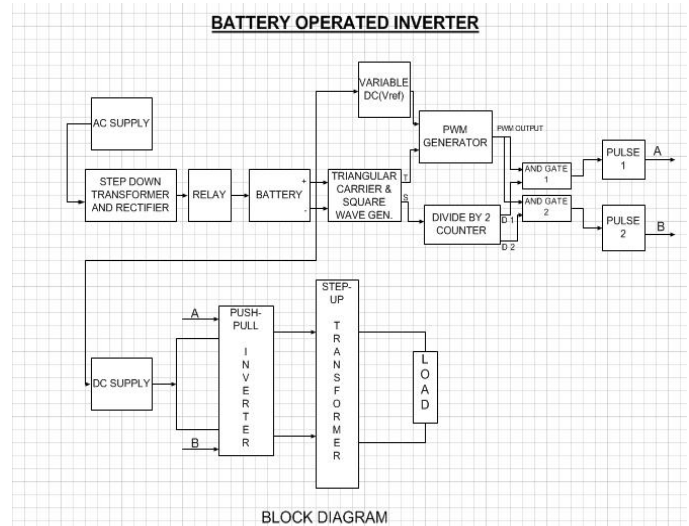

The ac supply is given to a step down transformer followed by a rectifier unit. The dc obtained is given to the relay COIL. The relay has 2 CO contacts. As per the relay operation, when ac supply is ON the battery is charged and supply is given to load. When the ac supply is OFF the battery gives supply to the inverter circuit and the output of it is given to the step up transformer and then fed to load.

## III. CONTROL SCHEME

To trigger switches of Push-Pull Inverter, the pulses are fed to the respective gate of IGBTs and they are kept 180 degree phase shifted with respect each other. For obtaining 50 Hz AC supply from the pulse generated from clock pulse generator (which are of 100 Hz) following steps are performed. A square wave of 100 Hz is given to integrator circuit which generates a triangular wave with DC offset. To remove this offset, a differential amplifier is used. The gain amplifier is connected at the output of the differentiator to increase the gain to the required value. This output is compared with a variable DC source ( $V_{ref}$ ) with the help of a comparator. The comparator gives PWM output. A divide by 2 counter (J-K FF) divides the square wave of 100 Hz into two square waves of 50 Hz which are out of phase with each other. The two waveforms are then performed AND operation with the PWM output. The two AND outputs are the required pulses to be fed to the switches of Push-Pull Inverter connected to the LV side of center tapped transformer.

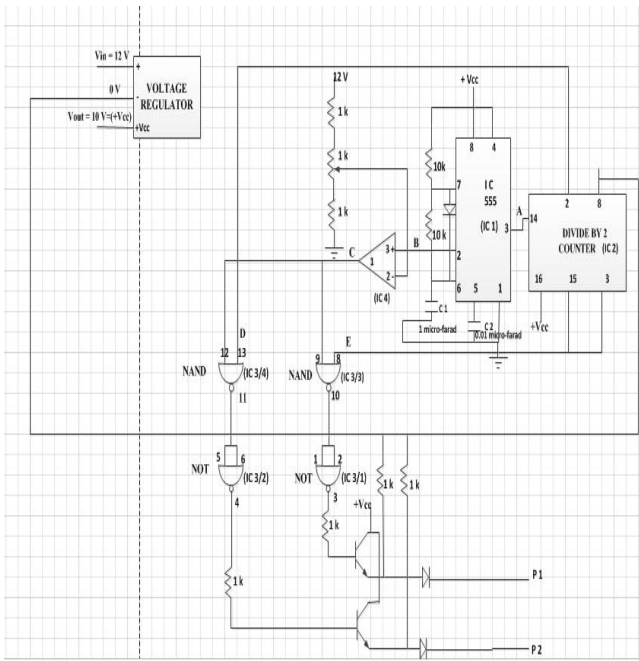

**IV. EXPECTED OUTPUT**

The output of the step-up transformer can be controlled since it is a PWM operated inverter. This battery operated inverter is equipped with automatic AC transfer switching. The inverter based on PWM technique has better protection and control circuits compared to the traditional inverters. The key advantage of PWM technique is that, the switching power loss is low. In OFF state, practically there is zero current, and in ON state when transferring power to the load, there is negligible voltage drop across the switch. Power loss, which is the product of voltage and current, is thus close to zero. Moreover PWM technique also works well with digital controls thus enabling the modification and setting of the desired duty cycle.

**V. RESULTS**

The hardware circuit was designed and tested to compare the expected results with the obtained results. The following comparative results reveal the same.

**1. Control circuit scheme**

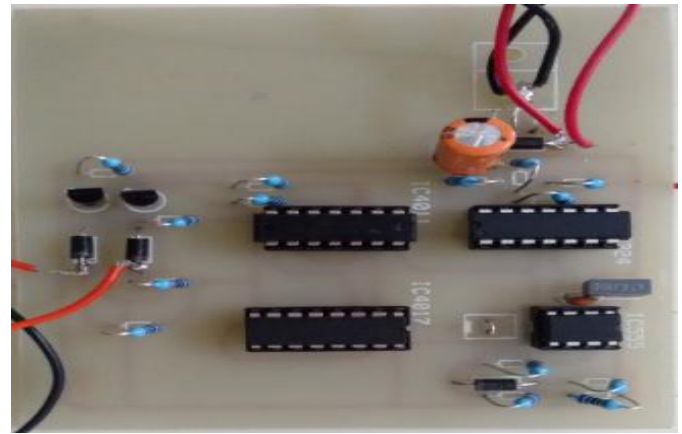

**2. GATE signals obtained from Control scheme**

(1) Higher Potentiometer setting

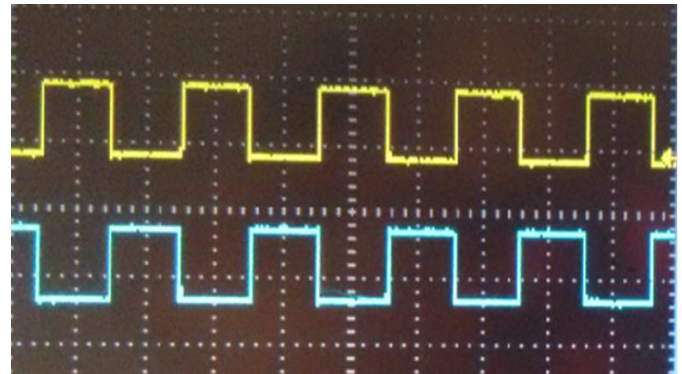

(2) Lower Potentiometer setting

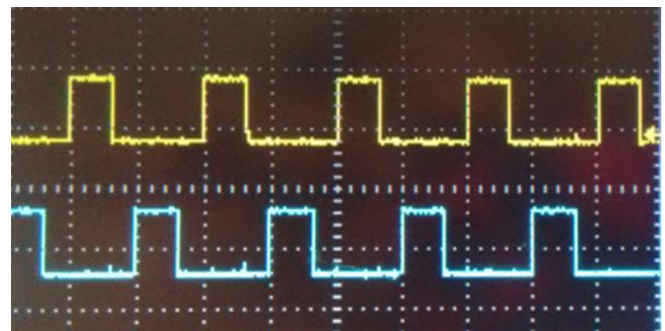

**3. Power circuit output**

(1) Higher Potentiometer setting

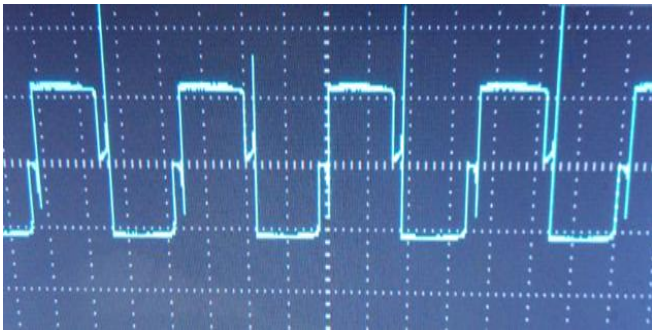

(2) Midpoint Potentiometer setting



(3) Lower Potentiometer setting



(4) With Resonant LC component

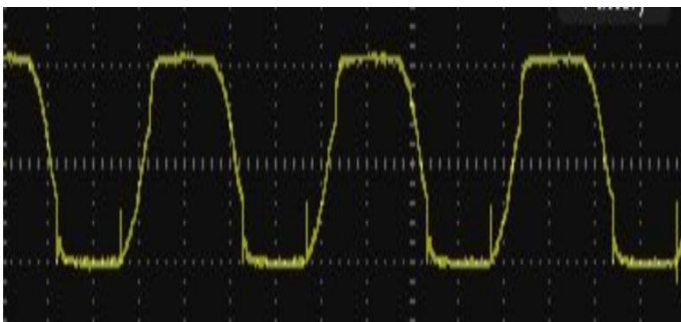

## VI. CONCLUSION

The hardware output results were found to be in order with the expected output waveform, for which the scheme has been proposed and designed.

## VII. SCOPE

To synchronize the Inverter ac output with the grid and feed the excess power to the grid. To design the charge controller for efficient battery charging from the Solar source. In this scheme, instead of comparators microcontrollers can be used for automation purpose. By changing transformer rating, we can drive different types of load as per the requirement.

## REFERENCES

- [1] K. Biju and Rijil Ramchand, "Modeling and simulation of a novel solar PV/ battery hybrid energy system with a single phase five level inverter", Signal Processing, Informatics, Communication and Energy Systems (SPICES), 2015 IEEE International Conference
- [2] Testa, S. De Caro, T. Scimone, S. Panarello, "A Buck-Boost based DC/AC Converter for Residential PV Applications", 2012 International Symposium on Power Electronics, Electrical Drives, Automation and Motion.
- [3] Md. Nahid HossainTushar Kanti Routh , Abdul Hamid Bin Yousuf , Miah Md. Asasduzaman, Md. Iqbal Hossain, Ummul Husnaeen, "Design and Development of Grid tied Solar Inverter", Informatics, Electronics & Vision (ICIEV), 2012 International Conference
- [4] K. Biju and Rijil Ramchand, "Control of a novel single phase grid connected solar PV/ battery hybrid energy system.", Control Conference (ASCC), 2015 10th Asian