

Smart Recycling Garbage Management System

Dr.R.Aghila¹, G.Balakrishnan², K.Nagalakshmi³, B.R.Iswarya⁴, U.Anandhi Packiam⁵
^{1,2,3,4,5} K.L.N.College of Information Technology

Abstract- The project is based on Image processing as well as on GSM module. The main concept is that a Camera will be placed at every garbage collection point along with load cell sensor at bottom of the garbage can. The camera will take continuous snapshots of the garbage can. A threshold level is set which compares the output of camera and load sensor. The comparison is done with help of microcontroller. After analysing the image we get an idea about level of garbage in the can and from the load cell sensor we get to know weight of garbage. Accordingly information is processed that is controller checks if the threshold level is exceeded or not. The controller sends a message with the help of GSM module to Garbage collection local central office to notify that garbage can is exceeded its capacity and disposal of waste is required. Accordingly the authority sends the garbage can collecting vehicle to collect the garbage, which is done with the help of robot mechanism. After collection of waste it is being dumped and energy is generated using the remaining temperature in waste.

Keywords- load cell, camera, images of garbage can, GSM module.

I. INTRODUCTION

Solid waste management is a big challenge in urban areas for most of the countries throughout the world. An efficient waste management is a pre requisition for maintain a safe and green environment as there are increasing all kinds of waste disposal. There are many technologies are used for waste collection as well as for well managed recycling. The Information gathering is big and cumbersome. The concurrent effects of a fast national growth rate, of a large and dense residential area and a pressing demand for urban environmental protection create a challenging framework for waste management. The complexity of context and procedures is indeed a primary concern of local municipal authorities due to problems related to the collection, transportation and processing of residential solid waste today the garbage collection is manual which takes a lot of efforts and is time consuming. In this project humans and vehicles were used to do that work and here we are using automatic technique to detect garbage level in Garbage Can. For that, ID number is given to each can. Also as soon as the Garbage Can is full / over flowing then a SMS is sent to the server from where all the garbage collection vehicles are allotted. Also we have a Load cell based weigh sensor which will sense the weight of the Garbage Can and when the weight crosses the set point the

SMS is sent to garbage collection centre. After the message is sent garbage disposal vehicle will arrive at that location. In this project it is demonstrated by robot mechanism.

II. SYSTEM DESIGN

A. Power Supply:

It is mainly used to provide DC voltage to the components on board. It supply 12V for DC motor, 3.3V for microcontroller and 5V for others.

B. Sensor

Web Camera: It is placed above the Garbage Can to capture images of the level of garbage in it. A webcam is a video camera that feeds or streams its image in real time to or through a computer to computer network. When "captured" by a computer, the video stream may be viewed, saved or sent on to other networks through the email by using internet . When this data is sent to a remote location, the video stream may be viewed, saved or on sent there, which is unlike an IP camera(which connects using Ethernet or (WiFi) a webcam is generally connected by using a USB cable, or by similar kind of cables.

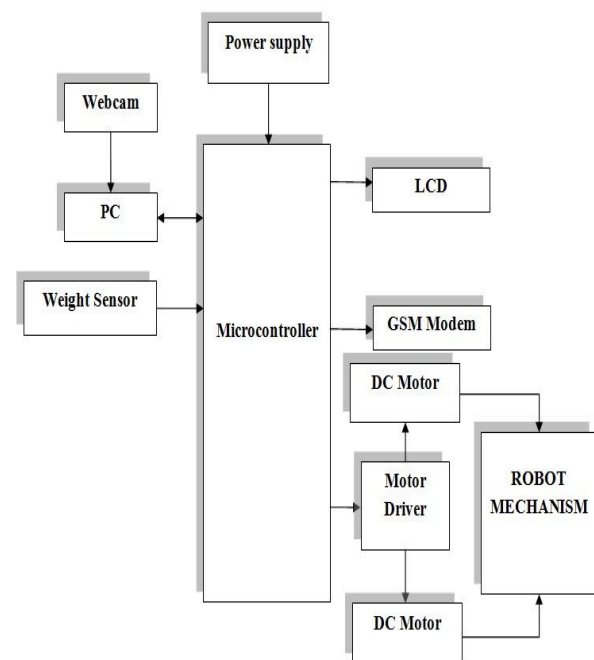

Fig1.System diagram

Load Sensor: Placed below the Garbage Can to sense the weight of it. The LOAD cell will continuously give the weight readings in voltage format, which is then given to a signal conditioning unit which amplifies the voltage and is then given to the μC . The μC then converts the analog signal to digital format. A load cell is a transducer that is used to sense and convert a force into an electrical signal. The output of the transducer can be scaled to calculate the force applied to the transducer. The various types of load cells are available, like include Hydraulic load cells sensor, Pneumatic load cells sensor and Strain gauge load cells sensor.

C. Microcontroller

It is used to process information that is been given by the sensors. It compares the received data with the threshold level set and accordingly output is generated. The LPC2131/32/34/36/38 microcontrollers are based on a 16/32-bit ARM7TDMI-S CPU with real-time emulation and embedded trace support, that combine the microcontroller with 32 kB, 64 kB, 128 kB, 256 kB and 512 kB of embedded high-speed flash memory. A128-bit wide memory interface and unique accelerator architecture enable 32-bit code execution at maximum clock rate.

D.LCD (Liquid Crystal Display)

LCD is used in a project to visualize the output of the application. We have used 16x2 LCD. So we can write 16 characters in each line. Total 32 characters we can display on 16x2 LCD.LCD can also use in a project to check the output of different modules interfaced with the microcontroller. Thus LCD plays a vital role in a project to see the output and to debug the system module wise in case of system failure in order to rectify the problem.

E.GSM Module

It is used to send message to the garbage depot if the Garbage Can exceeds the set threshold level. With the help of GSM module interfaced, we can send short text messages to the required authorities. GSM module is provided by sim uses the mobile service provider and send sms to the respective authorities as per programmed. It operates at either the 900 MHz or 1800 MHz frequency band.

F.Robot Mechanism

This robot mechanism is nothing but a machine capable of physical motion .In this project we use dc motor which is fixed on plate on which Garbage Can is mounted.

This plate is used for tilting the Garbage Can by which garbage is transferred into garbage collecting vehicle.

G.DC Motor

DC Motors are used to physically drive the application as per the requirement provided in software. To drive a dc motor, we need a dc motor driver called L293D. This dc motor driver is capable of driving 2 dc motors at a time.

III. IMPLEMENTATION METHODOLOGY

Each garbage can is given a number id which is stored in database with its location. A camera is placed at each garbage can .the camera used is INTEX IE305WC which is a 16 megapixel camera used for capturing images of garbage can continuously. A database is created in PC of different set levels which is used to compare with the images that are taken previously by camera. This is done with image processing. This is interfaced with microcontroller with help of RS232 cable. Simultaneously weighing sensor (load cell CZL601) is used .This is a single point load cell of total precision C3 class made up of material i.e. Aluminium alloy .It senses the weight of garbage can. It is interfaced with microcontroller through ADC.

The microcontroller compares the set limit with input data .if anyone or both input data crosses threshold level. Then microcontroller which is interfaced with GSM module sends a message to the server .The sent messages contains the slave id of the garbage can. The server compares the slave id with its database which contains record of slave id and location of each garbage can located in city. Then it gives exact location of the garbage can which is full or over weighted to the driver of waste disposal vehicle.

After receiving the message by the server the waste disposal vehicle reaches to the desired location. Then the driver enters set password with help of keypad in microcontroller. When the set password matches robot mechanism is activated. This robot mechanism is nothing but a machine capable of physical motion ,in this project we use dc motor which is fixed on plate on which garbage can is mounted .This plate is used for tilting the garbage can by which garbage is transferred into garbage collecting vehicle. Thus collecting all waste from localities it will make them looks cleaner and energy from the waste is all generated using the temperature of different waste and circulated to the needy.

IV.CONCLUSION

By implementing this project we will avoid overflowing of garbage from the container in society area which is previously either loaded manually or with the help of loaders in traditional trucks. Manual loading takes time and reduces the productivity of the vehicles and manpower deployed. Besides, manual handling of waste poses a threat to the health of the sanitation workers as the waste is highly contaminated.

REFERENCES

- [1] Yang Kai, Zhang Junmei, Li Wenbin, Yang Liu, GaoLin,XueHuixia,“Weighing System of FruitTransportation Gyrocar Based on ARM” IEEE computer society,2011 DOI 10.1109/ICMTMA.2011.253.
- [2] Arebey M.,Hannan, M.A. ; Basri, H. , Abdullah, H. “Solid waste monitoring and management using RFID, GIS and GSM ”IEEE Student Conference on Research and Development (SCOREd), 2009.
- [3] Arebey, M. ; Hannan, M.A. ; Basri, H. ; Begum, R.A., “Solid waste monitoring system integration based on RFID, GPS and camera”, IEEE International Conference on Intelligent and Advanced Systems (ICIAS), 2010.
- [4] Islam, M.S. ; Arebey, M. ; Hannan, M.A. ; Basri, H., “Overview for solid waste bin monitoring and collection system”,IEEE International Conference on Innovation Management and Technology Research (ICIMTR), 2012.
- [5] Alberto Rovettaa , Fan Xiuminb, c , Federico Vicentinia , , Zhu Minghuab, c , Alessandro Giustia , He Qichang “Early detection and evaluation of waste through sensorized containers for a collection monitoring application” Science Direct Journal.
- [6] Issac, R;Akshai,M.”An effective solid waste management system for Thiruvalla Municipality in Android OS” IEEE Conference Publications , 2013.
- [7] Longhi,S ; Marzioni,D ; Alidori, E ; Di Buo,G.; Pris,M. ; Grisostomi, M. ; Pirro,M. ”Solid Waste Management Architecture Using Wireless Sensor Network Technology“ ,New Technology , Mobility and Security (NTMS),2012 5 th International Conference.
- [8] Chen Tao; Li Xiang, “Municipal Solid Waste Recycle Management Information Platform Based On Internet of Things Technology”, Multimedia Information Networking and Security (MINES), 2010 International Conference.