

# Fundamental Study of Underwater Welding

**Prof. Amol A. Parihar**

Department of Mechanical Engineering  
MGM's Polytechnic Aurangabad, India

**Abstract-** *The paper describes principles of underwater welding and recent trends in research works undertaken for enhance welding technology and properties of underwater welds. The study on which this paper is based was conducted as part of a systematic research on fundamentals of underwater welding. The entire program covered various subjects including the heat transfer and flow during underwater welding, the mechanisms of metal transfer and arc bubble formation, and the effects of water environment on the metallurgical structures and the properties of underwater welds. Welding in offshore and marine application is an area of research and understanding where, many problems are still unsolved. In the present paper, a brief description of the different commercial underwater techniques has been made. The problems in underwater welding have also been discussed in context to the existing welding techniques. Detailed description of a few advanced welding techniques has also been made. Finally, the scope of further research has been recommended.*

**Keywords-** Underwater welding, wet welding, dry welding, TIG, MIG, laser, friction.

## I. INTRODUCTION

Welding processes have become increasingly important in almost all manufacturing industries and for structural application. Although, a large number of techniques are available for welding in atmosphere, many of them cannot be applied in offshore and marine application where presence of water is of major concern. In this regard, it is relevant to note that, a great majority of offshore repairing and surfacing work is carried out at a relatively shallow depth, in the region intermittently covered by the water known as the splash zone. This is predominantly because of the fact that the probability of failure is maximum at a shallow depth of water because of maximum collision probability between the ship and platform. Though, numerically most ship repair and welding jobs are carried out at a shallow depth, most technologically challenging task lies in the repairing at a deeper water level, especially, in pipelines and occurrence/creation of sudden defects leading to a catastrophic accidental failure.[1]

The advantages of underwater welding are of economical nature, because underwater-welding for marine maintenance and repair jobs bypasses the need to pull the structure out of the sea and saves much valuable time. The

main difficulties in underwater welding are the presence of a higher pressure due to the water head under which welding takes place, chilling action of the water on the weld metal (which might change the metallurgical structures and properties), the possibility of producing the arc mixtures of hydrogen and oxygen in pockets, which might set up an explosion, and the common danger sustained by divers, of having nitrogen diffused in the blood in dangerous proportions. Furthermore, complete insulation of the welding circuit is an essential requirement of underwater welding.

In practice, the use of underwater wet welding for offshore repairs has been limited mainly because of porosity and low toughness in the resulting welds. With appropriate consumable design, however, it is possible to reduce porosity and to enhance weld metal toughness through microstructure refinement. Hence, welding in offshore and marine application is an important area of research and needs considerable attention and understanding where, many problems are still unsolved. In the present review, a brief understanding of the problems in underwater welding will be discussed in context to the existing welding techniques. Detailed description of a few advanced welding techniques has also been made. Finally, the scope of further research would be recommended. [2],[3]

## II. CLASSIFICATION

Underwater welding can be classified as:-

**2.1 Wet Welding:** - In wet welding the welding is performed underwater, directly exposed to the wet environment. It is carried out directly at ambient water pressure with the welder/diver in the water using water-proof stick electrode and without any physical barrier between water and welding arc [Oates, 1996]. Special precaution should be taken to produce underwater arc to protect it from surrounding water. Wet welding does not need any complicated experiment set up, it's economical and can be immediately applied in case of emergency and accident as it does not need water to be evacuated. However, difficulties in welding operation due to lack of visibility in water, presence of sea current, ground swells in shallow water and inferior weld qualities (increased porosities, reduced ductility, greater hardness in the heat affected zone, hydrogen pick up from the environment) are the notable disadvantages of wet welding technique.[9].

**2.2 Dry Welding:** - In dry welding, a dry chamber is created near the area to be welded and the welder does the job by staying inside the chamber. Dry welding in underwater may be achieved by several ways:-[9]

**a. Dry habitat welding:-**

Welding at ambient water pressure in a large chamber from which water has been displaced, in an atmosphere such that the welder/diver does not work in diving gear. This technique may be addressed as dry habitat welding.

**b. Dry chamber welding:-**

Welding at ambient water pressure in a simple open-bottom dry chamber that accommodates the head and shoulders of the welder/diver in full diving gear.

**c. Dry spot welding:-**

Welding at ambient water pressure in a small transparent, gas filled enclosure with the welder/diver in the water and no more than the welder/diver's arm in the enclosure.

**d. Dry welding at one atmosphere:-**

Welding at a pressure vessel in which the pressure is maintained at approximately one atmosphere regardless of outside ambient water pressure.

**e. Cofferdam welding:-**

Welding inside of a closed bottom, open top enclosure at one atmosphere.

### III. PRINCIPLE OF OPERATION

#### 3.1 Wet Welding:-

The work to be welded is connected to one side of an electric circuit, and a metal electrode to the other side. These two parts of the circuit are brought together, and then separated slightly. The electric current jumps the gap and causes a sustained spark (arc), which melts the bare metal, forming a weld pool. At the same time, the tip of electrode melts, and metal droplets are projected into the weld pool. During this operation, the flux covering the electrode melts to provide a shielding gas, which is used to stabilize the arc column and shield the transfer metal. [5], [7].

#### 3.2 Dry Welding:-

Underwater welding in a dry environment is made possible by encompassing the area to be welded with a physical barrier (weld chamber) that excludes water. The weld chamber is designed and custom built to accommodate braces and other structural members whose centerlines may intersect at or near the area that is to be welded. The chamber is usually built of steel, but plywood, rubberized canvas, or any other suitable material can be used. Size and configuration of the chamber are determined by dimensions and geometry of the area that must be encompassed and the number of welders that will be working in the chamber at the same time. Water is placed from within the chamber by air or a suitable gas mixture, depending upon water depth and pressure at the work site. Buoyancy of the chamber is offset by ballast, by mechanical connections and chamber to the structure, or by a combination of both. [5],[7].

### IV. HYPERBARIC WELDING

Hyperbaric welding is carried out in chamber sealed around the structure to be welded. The chamber is filled with a gas (commonly helium containing 0.5 bar of oxygen) at the prevailing pressure. The habitat is sealed onto the pipeline and filled with a breathable mixture of helium and oxygen, at or slightly above the ambient pressure at which the welding is to take place. This method produces high-quality weld joints that meet X-ray and code requirements. The gas tungsten arc welding process is employed for this process. The area under the floor of the Habitat is open to water. Thus the welding is done in the dry but at the hydrostatic pressure of the sea water surrounding the Habitat.[6].

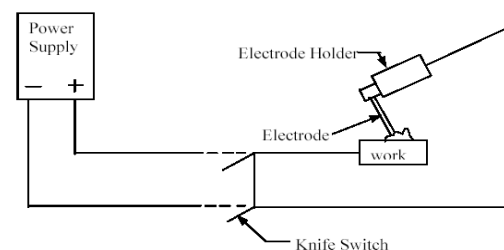

Figure 1: Hyperbaric welding

### V. RISK ASSOCIATED WITH UNDERWATER WELDING

There is a risk to the welder/diver of electric shock. Precautions include achieving adequate electrical insulation of the welding equipment, shutting off the electricity supply immediately the arc is extinguished, and limiting the open-circuit voltage of MMA (SMA) welding sets. Secondly, hydrogen and oxygen are produced by the arc in wet welding.

Precautions must be taken to avoid the build-up of pockets of gas, which are potentially explosive. The other main area of risk is to the life or health of the welder/diver from nitrogen introduced into the blood stream during exposure to air at increased pressure. Precautions include the provision of an emergency air or gas supply, standby divers, and decompression chambers to avoid nitrogen narcosis following rapid surfacing after saturation diving.

For the structures being welded by wet underwater welding, inspection following welding may be more difficult than for welds deposited in air. Assuring the integrity of such underwater welds may be more difficult, and there is a risk that defects may remain undetected.

## VI. CONVENTIONAL UNDERWATER WELDING TECHNIQUES

The fusion welding processes of greatest practical significance in underwater welding are manual shielded metal arc welding, tungsten inert gas welding, metal inert gas welding are used [Khanna,2004]. The principles of the above mentioned welding techniques are summarized below:

### 6.1 Shielded Metal Arc Welding:-

Shielded Metal Arc Welding (SMAW) is among the most widely used welding processes. During the process, the flux covering the electrode melts during welding. This forms the gas and slag to shield the arc and molten weld pool. Fig. 2 shows the schematic of shielded metal arc welding process. The slag must be chipped off the weld bead after welding. The flux also provides a method of adding scavengers, deoxidizers, and alloying elements to the weld metal. For underwater wet welding with shielded metal arc welding (SMAW) technique, direct current is used and usually polarity is straight [Khanna, 2004]. Electrodes are usually water proofed. Furthermore, it is flux coated which causes generation of bubble during welding and displaces water from the welding arc and weld pool area. Hence, the flux composition and depth of flux coating should be optimized to ensure adequate protection.

Electrodes for shielded metal arc welding are classified by AWS as E6013 and E7014 [Khanna, 2004]. Versatility, simple experiment set-up, economy in operation and finished product quality are notable advantages of the technique. However, during welding, all electrical leads, lighting gear, electrode holder, gloves, etc., must be fully insulated and in good condition. Ferrite electrodes with a coating based on iron oxide should be used as they resist hydrogen cracking. Flux cored arc welding is another technique which could not yet competed with SMAW because

of reported excessive porosities and problems with underwater wire feeding system [Oates,1996].

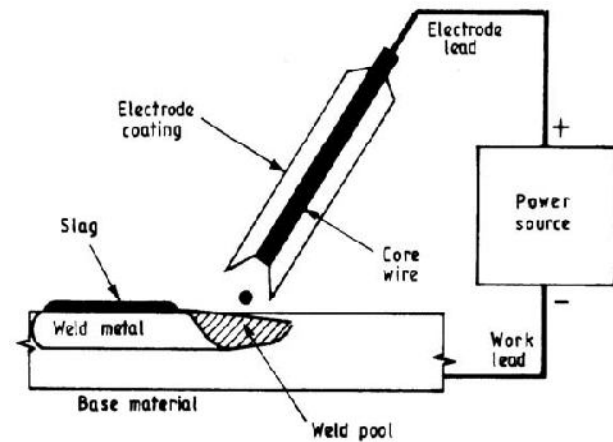

Figure 2: Schematic of shielded metal arc welding process

### 6.2 Flux Cored Arc Welding:-

Flux Cored Arc Welding (FCAW) is a commonly used high deposition rate welding process that adds the benefits of flux to the welding simplicity of MIG welding [Khanna, 2004]. As in MIG welding wire is continuously fed from a spool. Fig. 3 shows the schematic of flux cored arc welding process. Flux cored welding is therefore referred to as a semiautomatic welding process. Self shielding flux cored arc welding wires are available or gas shielded welding wires may be used. Less pre-cleaning may be necessary than MIG welding. However, the condition of the base metal can affect weld quality. Excessive contamination must be eliminated. Flux cored welding produces a flux that must be removed. Flux cored welding has good weld appearance (smooth, uniform welds having good contour). Flexibility in operation, higher deposition rate, low operator skill and good quality of the weld deposits are the notable advantages of flux cored arc welding. However, presence of porosities and burn back are the problems associated with the process. Recent development of nickel based flux cored filler materials have provided improved wet weldability and halogen free flux formulation specifically designed for wet welding application [Oates, 1996]. Similarly, improved underwater wet welding capabilities and halogen-free flux formulations have been developed with stainless steel flux-cored wires.

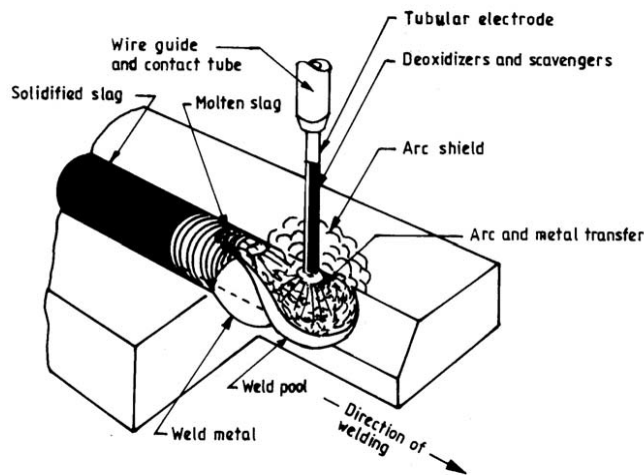

Figure 3: Schematic of Flux Cored Arc Welding

### 6.3 Tungsten Inert Gas Welding:-

TIG-welding (Tungsten Inert Gas) or GTAW-welding (Gas Tungsten Arc Welding) uses a permanent non-melting electrode made of tungsten [Khanna, 2004]. Filler metal is added separately, which makes the process very flexible. It is also possible to weld without filler material. TIG welding has got the advantage that it gives a stable arc and less porous weld. Fig. 4 shows the schematic of tungsten inert gas welding technique. The most used power source for TIG-welding generates alternating current (AC). Direct current can be used. AC TIG-welding usually uses argon as a shielding gas. The process is a multipurpose process, which offers the user great flexibility. By changing the diameter of the tungsten electrode, welding may be performed with a wide range of heat input at different thicknesses. AC TIG-welding is possible with thicknesses down to about 0,5 mm. For larger thicknesses, > 5 mm, AC TIG-welding is less economical compared to MIG-welding due to lower welding speed. DC TIG-welding with electrode negative is used for welding thicknesses above 4 mm. The negative electrode gives a poor oxide cleaning compared to AC-TIG and MIG, and special cleaning of joint surfaces is necessary. The process usually uses helium shielding gas. This gives a better penetration in thicker sections. In deep sea construction, free burning arc is used for fusion welding. The arc is then operated in a localized dry region created around the weldment at elevated pressures. Similar ambient conditions can be found in high pressure discharge lamps and in some plasma heaters and torches. The tungsten inert gas welding process at atmospheric pressures has been investigated extensively from the experimental and theoretical side [Lancaster,1987; Haddad and Farmer, 1985]. The properties of the free-burning arc column are studied for ambient pressures of 0.1 MPa (i.e., atmospheric) to 10 MPa for applications in underwater welding [Schmidt, 1996].

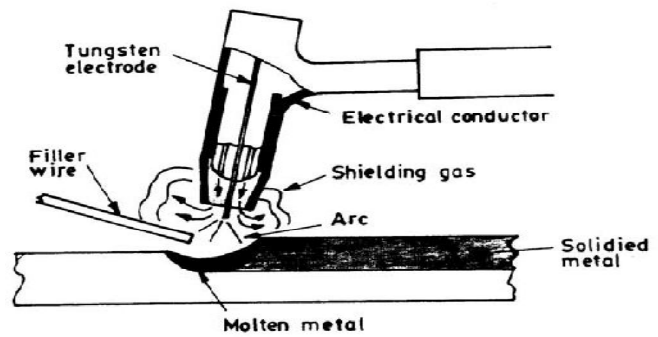

Figure 4: Schematic of a Gas Tungsten Arc Welding Technique

## VII. ADVANCED UNDERWATER WELDING TECHNIQUES

### 7.1 Friction welding (FRW):-

Friction welding is a solid state welding process which produces coalescence of materials by the heat obtained from mechanically-induced sliding motion between rubbing surfaces [Khanna,2004, Blakemore, 2000]. The work parts are held together under pressure. This process usually involves rotating of one part against another to generate frictional heat at the junction. When a suitable high temperature has been reached, rotational motion ceases and additional pressure is applied and coalescence occurs. Fig. 5 shows the schematic of friction welding process. The start of the new millennium will see the introduction of friction welding for underwater repair of cracks to marine structures and pipelines. There are two variations of the friction welding process. In the original process one part is held stationary and the other part is rotated by a motor which maintains an essentially constant rotational speed. The two parts are brought in contact under pressure for a specified period of time with a specific pressure. Rotating power is disengaged from the rotating piece and the pressure is increased. When the rotating piece stops the weld is completed. This process can be accurately controlled when speed, pressure, and time are closely regulated.

The other variation is called inertia welding. Here a flywheel is revolved by a motor until a preset speed is reached. It, in turn, rotates one of the pieces to be welded. The motor is disengaged from the flywheel and the other part to be welded is brought in contact under pressure with the rotating piece. During the predetermined time during which the rotational speed of the part is reduced the flywheel is brought to an immediate stop and additional pressure is provided to complete the weld. Both methods utilize frictional heat and produce welds of similar quality. Slightly better control is claimed with the original process. Among the advantages of friction welding is the ability to produce high quality welds in

a short cycle time. No filler metal is required and flux is not used. The process is capable of welding most of the common metals. It can also be used to join many combinations of dissimilar metals. It also produces a fine-grained forged weld without any weld dilution, or weld inclusions. Since there is never a liquid weld pool, hydrogen enrichment and hydrogen embrittlement are eliminated. Similarly nitrogen enrichment cannot occur. No shielding gasses or fluxes are required and it is possible to join dissimilar and exotic materials impossible to weld by any other means – including aluminium to ceramic.

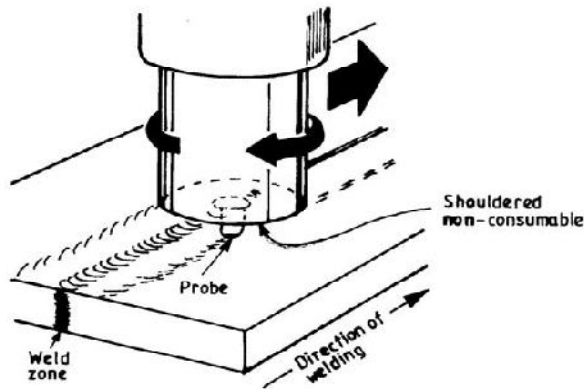

Figure 5: Schematic of Friction Welding Process

Friction welding requires relatively expensive apparatus similar to a machine tool. There are three important factors involved in making a friction weld:

1. The rotational speed which is related to the material to be welded and the diameter of the weld at the interface.
2. The pressure between the two parts to be welded. Pressure changes during the weld sequence. At the start it is very low, but it is increased to create the frictional heat. When the rotation is stopped pressure is rapidly increased so that forging takes place immediately before or after rotation is stopped.
3. The welding time. Time is related to the shape and the type of metal and the surface area. It is normally a matter of a few seconds. The actual operation of the machine is automatic and is controlled by a sequence controller which can be set according to the weld schedule established for the parts to be joined.

Normally for friction welding one of the parts to be welded is round in cross section; however, this is not an absolute necessity. Visual inspection of weld quality can be based on the flash, which occurs around the outside perimeter of the weld. Normally this flash will extend beyond the outside diameter of the parts and will curl around back toward the part but will have the joint extending beyond the outside diameter of the part. If the flash sticks out relatively straight from the joint it is an indication that the time was too short,

the pressure was too low, or the speed was too high. These joints may crack. If the flash curls too far back on the outside diameter it is an indication that the time was too long and the pressure was too high. Between these extremes is the correct flash shape. The flash is normally removed after welding.

## 7.2 Laser Welding:-

Laser as a source of coherent and monochromatic radiation, has a wide scope of application in materials processing [Steen, 1991; Dutta Majumdar and Manna, 2003]. Laser assisted welding, because of the sheer volume/proportion of work and advancement over the years, constitutes the most important operations among the laser joining processes [Dawas, 1992; Duley, 1999]. Fig.6 shows the front view of the schematic set up for laser underwater welding with a filler rod [Kruusing, 2004]. The focused laser beam is made to irradiate the work piece or joint at the given level and speed. A shroud gas protects the weld pool from undue oxidation and provides with the required oxygen flow. Laser heating fuses the work piece or plate edges and joins once the beam is withdrawn. In case of welding with filler, melting is primarily confined to the feeding wire tip while a part of the substrate being irradiated melts to insure a smooth joint. In either case, the work piece rather than the beam travels at a rate conducive for welding and maintaining a minimum heat affected zone (HAZ). There are two fundamental modes of laser welding depending on the beam power/configuration and its focus with respect to the work piece: (a) conduction welding and (b) keyhole or penetration welding (Figs. 7 a, b) [Dutta Majumdar, 2003]. Conduction limited welding occurs when the beam is out of focus and power density is low/insufficient to cause boiling at the given welding speed. In deep penetration or keyhole welding, there is sufficient energy/unit length to cause evaporation and hence, a hole forms in the melt pool. The 'keyhole' behaves like an optical black body in that the radiation enters the hole and is subjected to multiple reflections before being able to escape. The transition from conduction mode to deep penetration mode occurs with increase in laser intensity and duration of laser pulse applied to the work piece. Combination of laser beam with metal inert gas (MIG) or tungsten inert gas (TIG) arc (so-called hybrid technique) seems to be promising from the viewpoint of bead [Shida et al., 1997], but occurrence of large blowholes and voids still remains an important problem for further research.

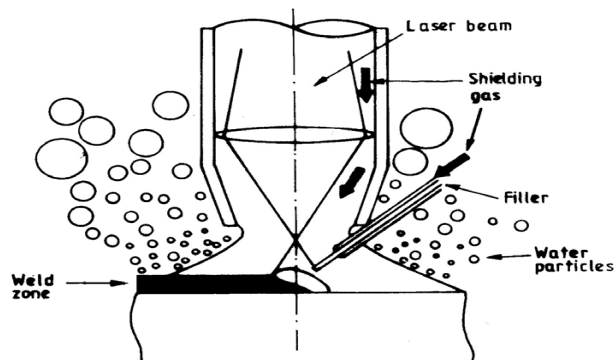

Figure 6: Schematic of laser welding with a filler rod.

Argon shroud removes heat and prevents undue oxidation and displaces water. The relative position of the laser focus determines the quality and configuration of the weld.

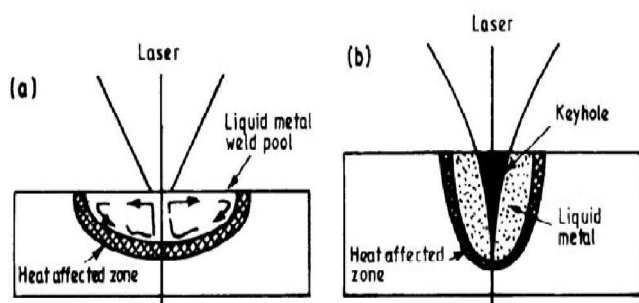

Figure 7: Schematic view of (a) Conduction melt pool, and (b) Deep penetration welding mode.

The surface boiling and marangoni effect are more in (a). Recently, Kern and his co-authors [Kern et al., 2000] showed that an intrinsic current is flowing in the melt pool driven by a thermoelectric potential. By applying an external magnetic field, they demonstrated the shaping of the seam cross-section, a reduction of pores, and a shift of the humping limit towards higher speed welding, in case of steel. Xiao et al. [Xiao et al., 2001] modified the magneto-fluid-dynamic approach by applying an electrical current through an external power source during laser welding. Fig. 8 shows the experimental setup. The external electric current was added to the weld pool through a 2.4 mm diameter tungsten electrode. The position of the electrode tip relative to the weld pool is defined by the distance to the laser beam axis "D". The laser system was a TLF5000 CO<sub>2</sub> laser and a TLC 100 five-axis laser processing machine. The focus number of the optics was 3.7 yielding a focus diameter of 0.3 mm. The focus position, optimized by experiments, was set 1 mm above the surface of the substrate. Bead-on-plate welds were made on 5 mm thick plates of Al99.5. Helium with a flow rate of 25 l/min was supplied by a side pipe with an inner diameter of 6 mm in order to suppress the laser induced plasma and protect the weld pool from the atmosphere. The electrical current flowing

in the weld pool induced an azimuthally magnetic field that was proportional to the current density and hence, electromagnetic forces proportional to the square of current density, were generated. Because of the divergence of the current lines from the electrode tip to the work-piece, the current density distribution is extremely non-uniform in the weld pool: the current density close to the electrode tip and the keyhole front is much larger than at the bottom and rear of the melt pool. Under their action, the molten metal in front of the keyhole is accelerated towards the bottom, which also brings the additional heat to the region. The weld depth, therefore, increases, while the width decreases. The distribution of electromagnetic forces and their magnitude are only determined by the current density distribution and do not depend on the current direction. That is why the position of the electrode affects the results and the change of the polarity has no influence. It was concluded that an external current can significantly influence the fluid flow of the weld pool and shape of the seam cross section in laser welding of aluminum, which results in improved flexibility. During deep penetration laser welding, the plasma over the keyhole absorbs beam energy and reduces the power efficiency. The thermal movement of laser produced plasma was analyzed theoretically and experimentally by [Peng et al., 2001].

The principle and feasibility of controlling the plasma by electric and magnetic fields were discussed. An experimental procedure involving elevating the nozzle during laser welding is used to evaluate the effect of increasing the power efficiency by driving away the charged particles. The power efficiency increased with increasing magnetic field intensity. There is an optimal electric field intensity at which the power efficiency reaches its highest value. It is indicated that by applying proper electric and magnetic fields the charged plasma particles can be driven away and the power efficiency is increased. Underwater laser assisted welding compared to the other underwater welding methods [Ogawa et al., 1998; Irie et al., 1997; Ogawa, 1998] has the advantages of low heat input, easy to transfer energy and control adaptability. The low heat input is of significance for reducing of the sensitivity of stainless steels to stress corrosion cracking (SCC). Underwater LBW has not been used in application, however, because a series of problems have not been solved yet. These include the method to transmit the laser beam to the work-piece and exclude the water from the welding zone, the laser-water/metal interactions and its influence on the welding process, the metallurgical behavior and properties of the repaired joint. In order to obtain ideal weld quality, however, one of the most important technologies is to develop a kind of effective method for real time monitoring of welding process in water. The plasma induced by the interaction of the laser beam and the metal vapor or the shielding gas in CO<sub>2</sub> laser

assisted welding has shielding effect on the laser beam, but the plume induced in Nd:YAG laser assisted welding has not such shielding effect on laser energy transferring. No matter CO<sub>2</sub> or Nd:YAG laser assisted welding, the optical emissions induced in the welding process indicate the basic characteristics of the keyhole and the variation of welding parameters.

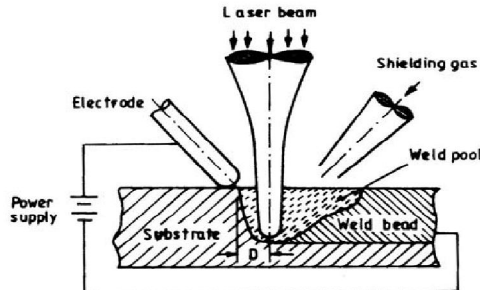

Figure 8: Schematic of experimental set-up for laser welding with an external current

Many bibliographies have studied the relationships between the optical emissions and the weld quality for in-air deep penetration LBW. Besides detecting the infrared radiation from the solidification area, detecting the plasma/plume signal or the reflected laser using optical sensors is a kind of simple and effective way to real-time monitor the welding process [Chen et al., 1998; Hugel et al., 1999; Chen et al., 1993]. In general, the optical emissions induced in laser welding can be detected from the side or coaxially with the laser beam [Chen et al., 1993]. The selection of the photodiode is dependent on the welding methods and the wavebands of photodiode are adjusted by filters. For instances, ultraviolet sensors are usually used to detect the plasma induced in CO<sub>2</sub> laser welding [Chen et al., 1993], visible-waveband sensors to detect the plasma/plume for both CO<sub>2</sub> and Nd:YAG laser welding [Chen et al., 1998; Hugel et al., 1999], and infrared sensors for both CO<sub>2</sub> and Nd:YAG laser welding [Chen et al., 1993; Farson et al., 1998]. The researches on the in-process sensing and controlling of the welding parameters, for example, focal position, has obtained good results and been used in application [Chen et al., 1998; Hugel et al., 1999]. The other research on the detecting of burnout or pin and humping defects using optical sensors was also reported [Shibata, 1996]. For underwater LBW, the weld quality not only depends on the welding parameters, but also the shielding conditions of the welding zone. Thus, the relationship between the shielding conditions of the local dry cavity and the weld quality, as well as the relationship to the optical emissions is also important. Zhang et al. [Zhang, 2004] presented the optical emissions characteristics with various shielding conditions and weld beads.

## VIII. CHARACTERISTICS OF A GOOD UNDERWATER WELDING

1. Requirement of inexpensive welding equipment, low welding cost easy to operate, flexibility of operation in all positions.
2. Minimum electrical hazards, a minimum of 20 cm/min welding speed at least.
3. Permit good visibility.
4. Produce good quality and reliable welds.
5. Operator should be capable in supporting himself.
6. Easily automated. [7]

## IX. APPLICATION OF UNDERWATER WELDING

The important applications of underwater welding are:

- (a) Offshore construction for tapping sea resources.
- (b) Temporary repair work caused by ship's collisions or unexpected accidents.
- (c) Salvaging vessels sunk in the sea.
- (d) Repair and maintenance of ships.
- (e) Construction of large ships beyond the capacity of existing docks. [13]

## X. FUTURE SCOPE

Considerable research effort has been made to improve process performance and control strategies for the various underwater welding processes over the last half century. However, there are still many problems to overcome. The major efforts on research and development should be focused on the following topics:

- a. Automation of the underwater joining and inspection of the welded structures.
- b. Mechanized underwater welding for actual usage of a very large floating structure.
- c. Investigation of the potential of using a robot manipulator for underwater ultrasonic testing of welds in joints of complex geometry.
- d. Application of advanced welding technique, like friction, laser welding and understand the behavior of materials after the welding and process optimization.
- e. Invention of new welding techniques and explore the possibility of its application in underwater welding.
- f. Generation of research data book on weld ability of materials during underwater welding.[15],[17].

## XI. CONCLUSION

Modern techniques of underwater welding give possibility of obtaining joints with sound welds that meets requirements of classification societies. Recent improvements

in underwater welding have led to the increased use of wet and dry hyperbaric welding for marine applications. But more spread application of wet welding methods is limited due to common opinion of low quality of welds performed by this method [2],[4],[24]. The general acceptance of underwater welding processes has been further advanced by the standardization of methods, procedures, and certification requirements provided by the American National Standards Institute and American Welding Society. In spite of many successful applications and results of investigations, underwater welding requires new research and development to achieve its full potential.

### REFERENCES

- [1] Blakemore, G. R. (2000): Underwater Intervention 2000 – Houston, Jan 24-26.
- [2] Chen W, Zhang X, et al. (1998): Proc SPIE, Vol. 3550, pp. 287–297.
- [3] Chen HB, Li L, Brookfield DJ, et al. (1993): Multi-frequency fiber optic sensors for in-process laser welding quality monitoring. Proc NDT E Int., Vol. 26, No. 2, pp. 268–274.
- [4] Dawas, C. (ed.) (1992): Laser Welding, Mc. Graw-Hill, N. York.
- [5] Duley W. W. (ed.) (1999): Laser Welding, John Wiley & Sons, Inc., N. York, pp. 1
- [6] Dutta Majumdar, J. And Manna, I. (2003): Sadhana, Vol. 28, pp. 495.
- [7] Farson D, Ali A, Sang Y. (1998): Weld Res Suppl., Vol. 77, No.: 4, pp. 142–148.
- [8] Haddad, G. N., Farmer, A. J. (1985): Weld. J., Vol. 64, No. 12, p. 339-342
- [9] Hugel H, Matthias G, Muller G, et al. (1999): Proc SPIE, Vol. 3571, pp. 52–60.
- [10] Irie T, Ono Y, Matsushita H, et al. (1997): Proceedings of 16th OMAE, pp. 43–50.
- [11] Kern, M, Berger, P., Ugel, H. H., (2000), Weld. J., Vol. 3, pp. 72.
- [12] Khanna, O. P. (2004): A Textbook of Welding Technology, Dhanpat Rai Publications (P) Ltd., N. Delhi, India.
- [13] Kruusing, A. (2004): Optics and Lasers in Engineering, Vol. 41, pp. 329–352.
- [14] Lancaster, J. F. (1987): The Physics of Fusion Welding – Part I: The Electric Arc in Welding, IEE Proc., Vol. 134, pp. 233 254
- [15] Oates W. A. (ed.) (1996): Welding Handbook, Vol. 3, American Welding Society, Miami, USA.
- [16] Ogawa Y, Irie T, Ono Y, et al., (1998): Proceedings of the 17th OMAE.
- [17] Ogawa Y. (1998): Proceedings of Eighth International Offshore and Polar Engineering Conference, vol. 4.
- [18] Peng, Y., Chen, W., Wang, C., Bao, G. and Tian, Z. (2001): J. Phys. D: Appl. Phys. Vol. 34 pp. 3145–3149
- [19] Schmidt, H.-P. (1996): IEEE Transactions on Plasma Science, Vol. 24, pp. 1229 – 1238
- [20] Shibata K. (1996): Proceedings of the ECLAT'96, pp. 49–58.
- [21] Steen, W. M. (ed.), (1991): Laser Material Processing, Springer Verlag, N. York.
- [22] Shida, T., Hirokawa, M. and Sato, S. (1997): Welding Research Abroad, Vol. 43, No. 5, pp. 36.
- [23] Xiao, R. S., Ambrosy, G., Zuo, T. C. and Hugel, H. (2001): J. Maters. Sci. Lett., Vol. 20, pp. 2163 – 2165.
- [24] Zhang, X., Chen, W., Eiji Ashida, E., Matsuda, F.(2004): Optics and Lasers in Engineering, Vol. 41, pp. 717– 730.

### AUTHOR PROFILE



Amol A. Parihar received the Diploma and BE in Mechanical Engineering from Government Polytechnic Jalna and Shram Sadhana Bombay Trust College of Engineering and Technology (SSBT COET) Jalgaon,(Maharashtra, India) respectively. Now he is working as Professor in MGM's Polytechnic Aurangabad since 2013.