

# Experimental Testing on Refrigerant Blend Using VCR System

D. Ramesh<sup>1</sup>, M. Sudhagar<sup>2</sup>, E. Sathees kumar<sup>3</sup>

<sup>1,2,3</sup> Department of Mechanical Engineering  
<sup>1,2,3</sup> The Kavery Engineering College, Salem, Tamil Nadu, India

**Abstract-** A refrigerant is a substance used in a heat cycle usually for enhancing efficiency, by a reversible phase transition from a liquid to a gas. Nowadays single refrigerants are used in commercial refrigeration system. Here we are using two different refrigerant mixed together and to improve the co-efficient of performance. R22 (Chloro di fluoro methane) and R134a (tetra fluoro ethane) are taken as test fluid. R134a and R22 is an inert gas used primarily as a “high-temperature” refrigerant for domestic refrigeration and automobile air conditioners. Selection of efficient and safe refrigerant blend for future has been attempted in this project through discussions. In order to improve the performance level of a refrigerant blends the different blending ratio are analyzed experimentally by using vapour compression refrigeration system.

The refrigerant blend which gives higher co-efficient of the performance have been taken for result discussion. The new blend gives performance better than the existing individual refrigerant. Performance parameters like refrigerant mass flow rate, refrigerant capacity, compressor power, C.O.P were analyzed at varying conditions. All the practical Performance parameters of R22 and R134a are compared by graphical representation. All the results were compared to find the improvement in co-efficient of performance.

**Keywords-** Domestic Refrigeration, Refrigerant of R22and R134a, Blends of Refrigerant

## I. INTRODUCTION

This Refrigeration literally means production of cooler temperatures and surroundings. It is more of an art than a science. Once consider as a luxury, it is now a necessity as it affects day-to-day functioning of human society. Refrigeration can be defined as per ASHARE guidelines as follows: “Refrigeration is the artificial removal of heat from a substance or a space to produce a temperature lower than that which would exist under the influence of ambient conditions.” In crude terms refrigeration is the science or art of cooling.

The most commonly used refrigerants in the late 1800s and in the early 1900s were natural refrigerants such as ammonia, carbon dioxide, sulphur dioxide and methyl

chloride. All these refrigerants were found to be toxic or hazardous. In 1928, a safer class of alternative refrigerants became available with the invention of chlorofluorocarbons (CFCs) and hydro chloro fluorocarbons (HCFCs). CFCs and HCFCs have many suitable properties such as stability, non-toxicity, non-flammable, good material compatibility and good thermodynamic properties, which led to their common wide spread use by both consumers and industries around the globe, especially as refrigerants in air-conditioning and refrigeration systems.

Here aim of our project is to improve the Co-efficient of Performance of a refrigeration system by refrigerant blend and our objectives are to find out the desirable properties of blends at different ratios, to determine the refrigeration effect or cooling load for the designed evaporator area, to find out the reason, for which property changes the refrigerant to increase their performance, to compare the performance of R22 & R134a with mixing of various blends, to reduce cooling time and power consumption by various blends.

## II. REFRIGERATION CYCLE

Refrigeration may be defined as the process to achieve and keep an enclosed space at a temperature lower than its surrounding temperature. This is done by continuous extraction of heat from the enclosed space whereas the temperature is below than that of the surrounding temperature. Generally refrigeration systems can be classified in 3 main cycle systems which are vapour Compression refrigeration system, vapour absorption refrigeration system, and gas cycle refrigeration system. However the vapour compression refrigeration system is the most widely used in the refrigeration process.

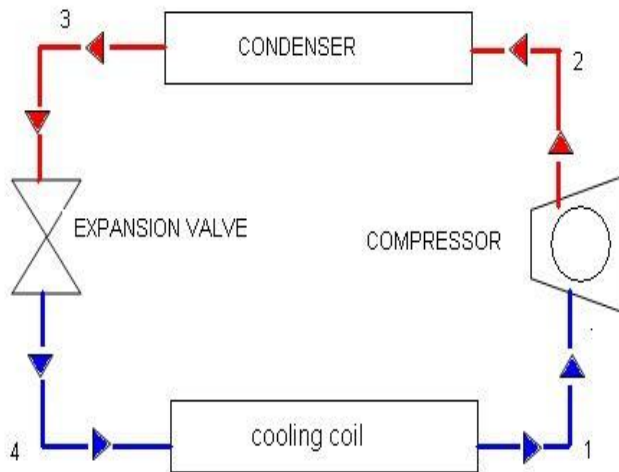

### 2.1 Representation of block diagram of Refrigerator

It is adequate for most refrigeration applications. The ordinary vapour compression refrigeration systems are simple, inexpensive, reliable and practically maintenance free. Most of the domestic refrigerators today are running based on the vapour compression refrigeration system. It is somewhat analogous to a reverse Rankine cycle. The vapour compression refrigeration system contains four main components which are compressor, condenser, expansion device, and evaporator. Compressor is used to compress the low pressure and low temperature of refrigerant from the evaporator to high pressure and high temperature. After the compression process the refrigerant is then discharge into condenser. In the condenser, the condensation process requires heat rejection to the surroundings.

The refrigerant can be condensed at atmospheric temperature by increasing the refrigerant's pressure and temperature above the atmospheric temperature. After the condensation process, the condensed refrigerant will flow into the expansion device, where the temperature of refrigerant will be dropped lower than the surrounding temperature caused by the reducing pressure inside the expansion device. When the pressure drops, the refrigerant vapour will expand.

As the vapour expands, it draws the energy from its surroundings or the medium in contact with it and thus produces refrigeration effect to its surroundings. After this process, the refrigerant is ready to absorb heat from the space to be refrigerated. The heat absorption process is to be done in the evaporator. The heat absorption process is normally being called as evaporation process. The cycle is completed when the refrigerant returns to the suction line of the compressor after the evaporation process. Low temperature refrigeration, at temperatures below  $0^{\circ}\text{C}$ , affects everyday life. It is mostly

used for food preservation, such as in the freezer of a refrigerator.

There are different kinds of refrigeration systems according to different refrigeration temperatures. For low temperature refrigeration with temperature above  $-20^{\circ}\text{C}$ , single -stage refrigeration systems are used, below  $-20^{\circ}\text{C}$ , two -stage systems or compound systems are used. The primary refrigerant for these systems is R-22. However, R-22 will be phased out due to environmental issues.

### 2.2 TS diagram:

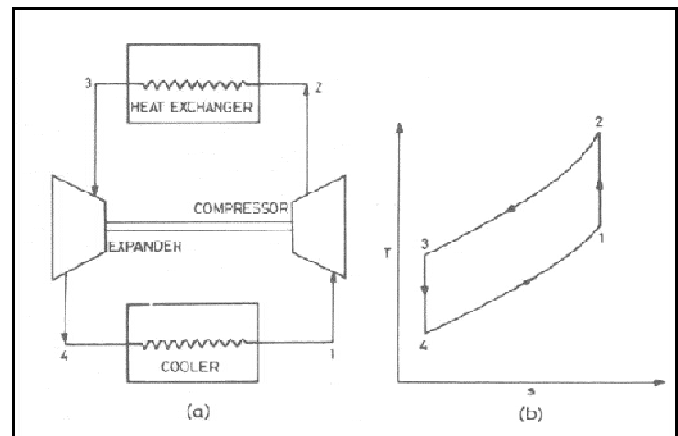

Fig.2.2 Representation of Ts diagram for refrigeration process

- Compression process (1 – 2)
- Condensation process (2 – 3)
- Expansion Process (3 – 4)
- Evaporation Process (4 – 1)

### 2.3 REFRIGERANTS:

- **Water:**
  - i) Working temp : above 3 degree Celsius.
  - ii) It is the cheapest, less corrosive & has high specific heat.
- **Brines:**
  - i) They are the solutions of NaCl & CaCl<sub>2</sub>.
  - ii) Used below the freezing point of water.
- **Ethylene glycol & Propylene glycol:**
  - i) Used as anti-freeze mixtures.
  - ii) Mixture with water makes colourless & odourless.
  - iii) Capacity to lower freezing point.

- **Halocarbon compounds:**
  - i) These contains one or more of 3 halogens i.e., chlorine, bromine or fluorine.

## 2.4 DESIRABLE PROPERTIES OF GOOD REFRIGERANT:

### 2.4.1 Thermodynamic Properties

- **Boiling Point:** It should have Low Boiling Point.
- **Freezing Point:** It should be below the Evaporator temperature.
- **Evapourative Pressure:** It should be above Atmospheric pressure.
- **Condensing Pressure:** It should have LOW Condensing pressure.
- **Latent Heat of Vapourisation:** It should have HIGH Latent heat of Vapourisation.
- **Critical Temperature & Pressure :** It should be above the condensing Temperature & Pressure.

### 2.4.2 Chemical Properties

- **Toxicity:** It should not be Poisonous or injurious . It should not be non-irritating to eyes.
- **Corrosiveness:** It should not be corrosive & should not have any effect on materials used in equipment.
- **Leak Detection:** It should have less tendency to leak & if it is leaking it should be easily detectable.
- **Flammability:** It should not be Inflammable.
- **Miscibility with Oil:** It should be immiscible with oil & should not have any effect on the properties of Oil used for Lubrication.
- **Effect on Foodstuff:** It should not affect on food articles or make them poisonous or unportable.
- **Stability:** It should be capable of withstanding high pressure & temperature.

### 2.4.3 Physical Properties

- **Specific Volume:** It should be LOW in Vapour state.
- **Viscosity:** It should have LOW viscosity.
- **Thermal Conductivity:** It should have HIGH Thermal Conductivity.
- **Di-Electric Strength:** It should have High strength.

### 2.4.4 Other Properties

- **Handling & Maintenance:** It should be easy & safe to handle.

- **Cost & Availability:** It should be readily available at LOW cost.
- **Performance of the System:** It should have high COP & LOW power requirement.

## III. PERFORMANCE ANALYSIS

### 3.1 Performance test calculations for R134a:

Gas: R134a

Room Temperature: 32 °C

Table 3.1 Experimental readings when loaded with R134a

Description	Properties	Values
Initial temperature of water (°C)	T5	27
Final temperature of water (°C)	T5	12
Duration of experiment (sec)	dt	4644
Delivery pressure (kg/cm <sup>2</sup> )	P1	14.5
Delivery temperature (°C)	T1	42.3
Condenser outlet pressure (kg/cm <sup>2</sup> )	P2	15.2
Condenser outlet temperature (°C)	T2	41.7
Pressure after throttling (kg/cm <sup>2</sup> )	P3	14.1
Temperature After throttling (°C)	T3	28.3
Suction pressure (kg/cm <sup>2</sup> )	P4	13.2
Suction temperature (°C)	T4	12
Time for 10 rev. of energy meter (sec)	t	236

### 3.2 Performance test calculations for R22:

Gas: R22

Room Temperature: 32 °C

Table 3.2 Experimental readings when loaded with R22

Description	Properties	Values
Initial temperature of water (°C)	T5	27
Final temperature of water (°C)	T5	12
Duration of experiment (sec)	dt	4860
Delivery pressure (kg/cm <sup>2</sup> )	P1	17.8
Delivery temperature (°C)	T1	47.5
Condenser outlet pressure (kg/cm <sup>2</sup> )	P2	17.3
Condenser outlet temperature (°C)	T2	39.8
Pressure after throttling (kg/cm <sup>2</sup> )	P3	16.7
Temperature After throttling (°C)	T3	32.1
Suction pressure (kg/cm <sup>2</sup> )	P4	16.2
Suction temperature (°C)	T4	12
Time for 10 rev. of energy meter (sec)	t	260

### 3.3 Performance test calculations for RB2\*

Gas: R134a/R22 (50:50)

Room Temp.: 32 °C

Table 3.3 Experimental readings when loaded with R134a/R22 (50:50)

Description	Properties	Values
Initial temperature of water (°C)	T5	27
Final temperature of water (°C)	T5	12
Duration of experiment (sec)	dt	4356
Delivery pressure (kg/cm <sup>2</sup> )	P1	12.5
Delivery temperature (°C)	T1	37.6
Condenser outlet pressure (kg/cm <sup>2</sup> )	P2	12.5
Condenser outlet temperature (°C)	T2	35.9
Pressure after throttling (kg/cm <sup>2</sup> )	P3	12.5
Temperature After throttling (°C)	T3	34.3
Suction pressure (kg/cm <sup>2</sup> )	P4	12.2
Suction temperature (°C)	T4	12
Time for 10 rev. of energy meter (sec)	t	342

\*RB2 refers to the R134a/R22 (50:50) mixture

**3.4 Performance test calculations for RB3\***

**Gas:** R134a/R22 (70:30)      **Room Temperature:** 32 °C

Table 3.4 Experimental readings when loaded with R134a/R22 (70:30)

Description	Properties	Values
Initial temperature of water (°C)	T5	27
Final temperature of water (°C)	T5	12
Duration of experiment (sec)	dt	4392
Delivery pressure (kg/cm <sup>2</sup> )	P1	15.2
Delivery temperature (°C)	T1	42.7
Condenser outlet pressure (kg/cm <sup>2</sup> )	P2	16.2
Condenser outlet temperature (°C)	T2	39.8
Pressure after throttling (kg/cm <sup>2</sup> )	P3	14.4
Temperature After throttling (°C)	T3	28.8
Suction pressure (kg/cm <sup>2</sup> )	P4	14.7
Suction temperature (°C)	T4	12
Time for 10 rev. of energy meter (sec)	t	250

\*RB3 refers to R134a/R22 (70:30) mixture

**3.5 Performance test calculations for RB1\***

**Gas:** R134a/R22 (30:70)      **Room Temperature:** 32 °C

Table3.5 Experimental readings when loaded with R134a/R22 (30:70)

Description	Properties	Values
Initial temperature of water (°C)	T5	27
Final temperature of water (°C)	T5	12
Duration of experiment (sec)	dt	4860
Delivery pressure (kg/cm <sup>2</sup> )	P1	17.1
Delivery temperature (°C)	T1	46.1
Condenser outlet pressure (kg/cm <sup>2</sup> )	P2	16.2
Condenser outlet temperature (°C)	T2	41.9
Pressure after throttling (kg/cm <sup>2</sup> )	P3	15.6
Temp. After throttling (°C)	T3	30.9
Suction pressure (kg/cm <sup>2</sup> )	P4	15.3
Suction temperature (°C)	T4	12
Time for 10 rev. of energy meter (sec)	t	240

\*RB1 refers to R134a/R22 (30:70) mixture

**3.6 COP of Various Refrigerants:**

Parameters	Formulae	Values for RB1	Values for RB2	Values for RB3	Values for R22	Values for R134a
Mass of water in the evaporator vessel, (m) Kg	$\rho_w (l \times b) \times h$	13.05	13.05	13.05	13.05	13.05
Specific heat of water, (Cp) KJ/Kg°C	-	4.18	4.18	4.18	4.18	4.18
Rate of fall in temperature of water, OC/sec	dT/dt	0.00308	0.00344	0.00341	0.00308	0.00322
Refrigeration effect, (R) KW	$mcp \text{ dT/dt}$	0.168	0.1877	0.186	0.154	0.175
Work done by the compressor(W) KW	$(3600 \times 10) / (t \times E)$	0.098	0.0738	0.0975	0.0952	0.1016
COP of the refrigeration system	R/W	1.702	2.54	1.907	1.617	1.732

Where;

t= time taken for 10 revolution of energy meter  
 E= energy meter constant=1500 rev/KW hr

**IV. PROPOSED SYSTEM**

The experimental setup made with reference to basic vapour compression refrigeration system. The test fluid we taken was R22 (Chloro di fluoro methane)



Fig.4.1. VCR circuit diagram

### 4.1 Components and Specifications

The experimental consists of compressor, fan cooled condenser, expansion device and an evaporator section. Capillary tube is used as an expansion device. The evaporator is of rectangular type which is loaded with water. Service ports are provided at the inlet of expansion device and compressor for charging the refrigerant.

The component specifications are given below:

Compressor	:	Reciprocating compressor
Condenser	:	Fin type Air cooled condenser
Liquid filter	:	Micro filler
Evaporator volume:	:	43.5×12×25 cm <sup>3</sup>
Evaporator capacity:	:	13 litres flask capacity
Pressure gauge	:	0-35 kg/cm <sup>2</sup>
Thermometer	:	Digital thermometer
Energy meter	:	Single phase AC
Voltmeter	:	AC (Range 0-300 Volt)
Ammeter	:	AC (Range 0-5 Amps)

### 4.2 Measurement

The temperatures at different parts of the experimental setup are measured using digital thermometer. 5 digital thermometers were used for the experimentation. The pressure at compressor suction, discharge, condenser outlet and at evaporator outlet is measured with the help of pressure gauges. The power consumption of the system was measured by a Watt-hr meter. A wattmeter, ammeter, voltmeter are also connected with the experimental setup.

### 4.3 Experimental procedure

The procedure for the conduction of experiments is as follows:

- A performance test is made with the system loaded with pure R134a.
- The data is treated as the basis for the comparison with the refrigerant mixtures.
- Another performance test is made with the system loaded with pure R22.
- This data is also treated as the basic for the comparison with the blended refrigerants.
- Mixture of R22 and R134a by mass in the proportion 30:70, 50:50 and 70:30 was charged in the compressor and the performance tests were conducted.
- All the tests were taken out at ambient temperature of 32°C.
- Half the volume of the evaporator is loaded with water throughout the experiment.

- The required data are collected and tabulated to find out COP of the system.

## V. RESULT AND DISCUSSION

The overall performance of vapour system was evaluated by the refrigerant blends and the operational parameters such as energy consumption (input to the compressor) of the system. The coefficient of performance was calculated using the experimental readings and used to compare the COPs of the blends with that of individual refrigerants. Figure 5.1 shows the variations in COP of individual refrigerant and blended refrigerant. The COP of RB2 seems to be maximum. This shows that compressor work is minimised at this ratio.

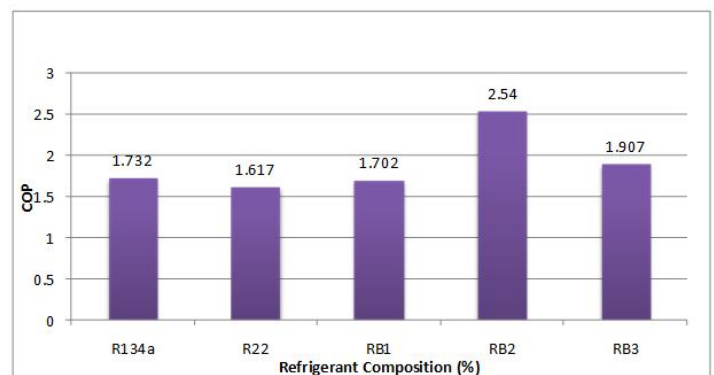

Fig. 5.1 Variation of COP with Refrigerant mixture

Figure 5.2 shows the Variation of Discharge Temperature of compressor with time. The discharge temperature of RB2 is slightly similar to the R134a and figure 5.3 shows the discharge pressure with time. As the discharge pressure reduces with time, it shows that compressor work is reduced and increase the performance of the system.

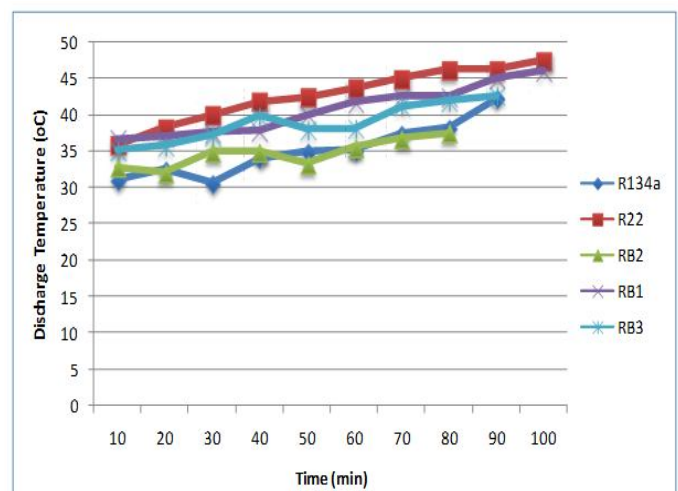

Fig. 5.2 Variation of Discharge Temperature of compressor with time

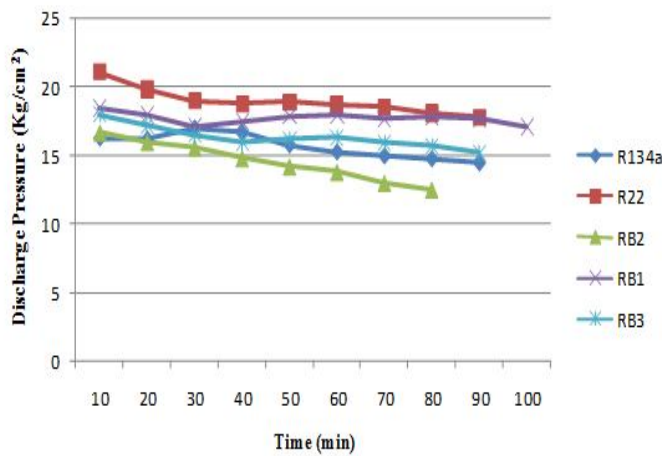

Fig. 5.3 Variation of Discharge Pressure of compressor with Time

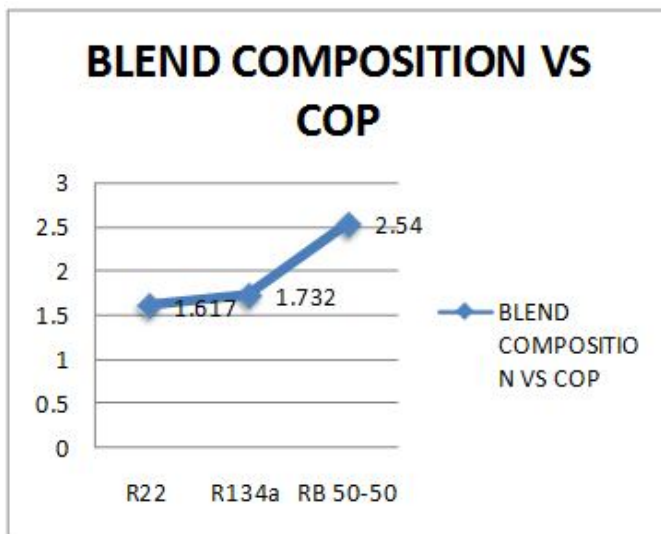

Fig.5.4.blend composition vs coefficient of performance

In fig 5.4 the refrigerant composition of 50-50 mixture of R134a and R22 is gives best co efficient of performance compared to the individual refrigerant. So the performance of blended refrigeration system is high compared to the single pure refrigerant.

### VI. CONCLUSION

- The vapour compression unit was manufactured and various refrigerants pass through the system according to the blended ratio.
- The Co-efficient Of Performance has been increased by the blended refrigerant.
- Hence the optimum level of efficiency is obtained by blended refrigerants. In this investigation the combinations of R134a+R22 has have increased the Co-efficient Of Performance.

- The mixture of R134a and R22 works safely in the system without any system modification.
- The COP value increases and the maximum COP was obtained for 50:50 mixtures of R134a and R22.
- Higher value of COP found experimentally is 2.54

### REFERENCES

- [1] Akintunde, M.A. (2013) ‘Experimental Study of R134a, R406A and R600a Blends as Alternative To Freon 12’, Volume 7, Issue 1, PP 40-46.
- [2] Giuliani.G, F. Marchesi Donati, S. Nobili, F. Polonara, (1998), ‘Experimental Comparison of the Performance of Refrigerants R134a and R32/R134a in Dry Expansion and Liquid Recirculation Refrigerating Systems’, International Refrigeration and Air Conditioning Conference, Paper 389.
- [3] Govindharajan . B, C. Chelladurai, J. Parthiban, and R. Manikandan (2013) ‘Prediction of Cop of a CO<sub>2</sub>/R134a Mixture with Portable VAPOUR Compression Refrigeration System’, Volume 3, PP 487-494.
- [4] Jim Lavelle, (2006), ‘Understanding Refrigerant Blend Performance’, RSES Journal.
- [5] National Refrigerants, (2004), ‘Refrigerant Reference Guide’, Fourth Edition.
- [6] Sendil Kumar.D, Dr.R.Elansezhian (2012) ‘Investigation of R152a/R134a Mixture in Refrigeration System’, Volume 2, Issue 6.