

GSA Based Optimal Pitch Controller Design For An Isolated Wind-Bio Mass Hybrid Power System

D.Kalaichelvi

Assistant Professor, Dept of EEE
CK College of Engineering and Technology

Abstract- In this paper, Gravitational Search Algorithm based optimal pitch controller design is proposed for an isolated wind-diesel hybrid power system. The Gravitational search algorithm (GSA) is one of the newest meta-heuristic searching algorithms, which is motivated by the Newton's laws of gravity and law of motion. The optimal controller parameters are obtained using Integral Square Error (ISE) criterion. Simulation results show that the performance of the proposed Controller damps out the frequency deviation and attains the steady state value with less settling time.

I. INTRODUCTION

For the technological development of mankind, energy has been the major driving force. As the world population increases, the demand for energy also increases. Environmental degradation, social problems, global warming, climate change, etc., are some of the issues that arise from energy demand and use. The opportunity to mitigate the consequences of energy usage has been provided for wind energy. In many regions of the world, wind energy has been proved to be sustainable and abundantly available. Today, a good source of employment around the world is the industry of wind energy. Job opportunities are created by wind technologies such as generators, power converters, and turbines which foster the export markets. In the last 20 years, power capabilities achieved from turbines have increased by a factor of 100 and the cost of energy from wind turbines has been reduced. The industry has been developed to the edge of conventional power generation. The wind power undergoes three main stages before being integrated into the grid: harnessing of wind resources, conversion of the harnessed wind resources into electrical power, and integration of the wind power into the grid [1]. There must be a stand-by power source to meet load demand since the wind power varies randomly. Wind and diesel system is one of the hybrid systems which utilizes more than one energy source. A hybrid wind and diesel system is more reliable because the diesel system acts as a cushion to take care of variation in wind speed. Also it provides the power equal to load power minus the wind power[2].

A number of strategies [2,3,5,15,16,17] have been employed for the suitable control of the wind-diesel hybrid power system. In recent years, Artificial Intelligence based controllers have received increasing attention

In this work, a new optimization algorithm based on law of gravity, namely Gravitational Search Algorithm (GSA) is proposed. This algorithm is based on Newton's law of gravity which states that: "Every particle in the universe attracts every other particle with a force that is directly proportional to the product of their masses and inversely proportional to the square of the distance between them". The designed PI controller with proposed approach is simulated and its performance is compared with that obtained from conventional approach.

II. SYSTEM CONFIGURATION

The model considered here consists of the following sub-systems:

- (i) Wind dynamics model,
- (ii) Diesel dynamics model,
- (iii) Blade pitch control of wind turbine,
- (iv) Generator dynamics model.

The wind model is a unique feature of the wind turbine generator and is not required for diesel generator system in the stability programme. A model which is presented by Anderson [2], can properly simulate the effect of wind behavior, including gusting, rapid (ramp) changes and background noise. The basic condition for startup and synchronization is that the wind speed is to be within acceptable range and there must be a phase match between the generator voltage and system voltage [3].The diesel dynamics is associated with diesel power. The nature of the dynamic behavior in this model is dominated by the diesel speed governor controller. A total power set point is selected in such a manner that it can be manually adjusted from zero to maximum value. The purpose of the adjustable power set point is to allow system utility personnel to lower the power setting than the maximum settings of the wind generator. Also

it prevents diesel control from dropping to less than 50% of the rated power.

Pitch control has the potential for producing the highest level of interaction because of the presence of both diesel and wind turbine control loops. When wind power raises above the power set point the pitch control system begins operating to maintain an average power equal to the set point. The pitch control system consists of a power measurement transducer, a manual power set point control, a proportional plus integral feedback function, and a hydraulic actuator which varies the pitch of the blades. Turbine blade pitch control has a significant impact on dynamic behavior of the system. This type of control only exists in horizontal axis machines. Variable pitch turbines operate efficiently over a wider range of wind speeds than fixed pitch machines. However cost and complexity are higher. Generator dynamics model consists of a synchronous generator driven by a diesel engine through a flywheel and connected in parallel with an induction generator driven by a wind turbine. The diesel generator will act as a dummy grid for the wind generator which is connected in parallel. Variations of electrical power due to changes in wind speed should be as small as possible; this is obtained by using induction generator as a wind turbine drive train. Unlike synchronous generators, induction generators are high compliance couplings between the machine and the electrical system. This is true for induction generators with slip of at least 1-2% at rated power [4, 5]. The controlled variables are turbine speed and shaft torque. Control acts on the turbine blade angle (pitch control), since the torque speed characteristic of the induction generator is nearly linear in the operating region, torque changes are reflected as speed changes. Therefore, it is possible to provide a single speed controller to control speed as well as torque.

Figure 1 shows the basic configuration of a wind and diesel turbine generation system

Optimization of the proportional plus integral gains of the blade pitch control mechanism is performed by using the performance index (cost function)

$$J = \int_0^t [\Delta F_1^2 + \Delta F_2^2 + \Delta P_{\omega}^2] dt$$

III. GRAVITATIONAL SEARCH ALGORITHM

Gravitational Search Algorithm [6] is a population based search algorithm based on the law of gravity and mass interaction. The algorithm considers agents as objects consisting of different masses. The entire agents move due to the gravitational attraction force acting between them and the progress of the algorithm directs the movements of all agents globally towards the agents with heavier masses. Each agent in Gravitational Search Algorithm is specified by four parameters: Position of the mass in d^{th} dimension, inertia mass, active gravitational mass and passive gravitational mass. The positions of the mass of an agent at specified dimensions represent a solution of the problem and the inertia mass of an agent reflect its resistance to make its movement slow. Both the gravitational mass and the inertial mass, which control the velocity of an agent in specified dimension, are computed by fitness evolution of the problem. The positions of the agents in specified dimensions (solutions) are updated with every iteration and the best fitness along with its corresponding agent is recorded. The termination condition of the algorithm is defined by a fixed amount of iterations, reaching which the algorithm automatically terminates. After termination of the algorithm, the recorded best fitness at final iteration becomes the global fitness for a particular problem and the positions of the mass at specified dimensions of the corresponding agent becomes the global solution of that problem.

The algorithm for GSA is explained as follows:

- Step1: Search space identification.
- Step2: Randomized Initialization.
- Step3: Fitness evaluation of agents.
- Step4: Update $G(t)$, $best(t)$, $worst(t)$ and $Mi(t)$ for $i=1,2,\dots,N$.
- Step5: Calculation of the total force in different directions.
- Step6: Calculation of acceleration and velocity.
- Step7: Updating agents' position.
- Step8: Repeat steps 3 to 7 until the stop criteria is reached.
- Step9: End.

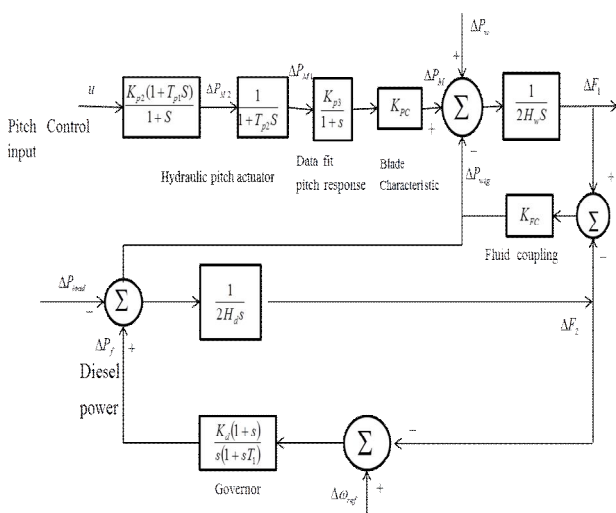

Fig. 1: Transfer function model block diagram of an isolated wind-diesel hybrid power system

IV. IMPLEMENTATION OF GRAVITATIONAL SEARCH ALGORITHM

The effective application of gravitational search algorithm is to optimize the parameters in optimal pitch control of an isolated wind energy conversion system. The proportional gain (K_p) and integral gain (K_i) have been optimized to ensure best performance of the system. The implementation of Gravitational Search algorithm for the design of optimal pitch Controller involves following steps.

1. The objective function (J) is calculated for each set of K_p and K_i .
2. The objective function value is then mapped into a fitness value for each set. An appropriate fitness value is obtained using the equation, $Fitness = 1/(1+J)$
3. When fitness values are found, Gravitational Search Algorithm proceeds with its algorithmic steps.

These steps are repeated till the termination condition is satisfied and the gain parameter set corresponding to the recorded best fitness is the optimum gain parameter set.

V. SIMULATION RESULTS

The Gravitational search algorithm is applied to obtain the optimal pitch controller for the hybrid wind-diesel energy conversion system is obtained. The parameters used for modeling are given in Appendix. The gains of PI controller are designed by using classical method and GSA. Performance of each controller is examined from dynamic behavior in time-domain simulations of the system in isolated mode of operation. The optimal K_p and K_i values obtained from conventional controller and Gravitational search algorithm based optimal pitch controller are shown in table 1.

Table 1: Optimal controller parameters:

Controller gains	K_p	K_i	J
Conventional controller	7.6	1.5	0.425
GSA based controller	3.66	0.59	0.374

It is observed from table 1 that the cost function value reduces for the optimal gain parameters obtained with GSA tuned controller.

The control parameters for GSA are given in Table 2.

Table 2: GSA control parameters

Table 3. Setting parameters of GSA approach for different operating conditions

Setting Parameters			
N	G_0	α	T
10	100	10	25

The closed loop responses of $df1, df2, dpwg, dpd$ of the wind-diesel hybrid power system obtained using GSA based controller, for a step load change of 0.01 p.u. kW, are given in fig.2. For easy comparison, the responses obtained using conventional controller are also plotted. The results show that the Gravitational Search Algorithm based controller provides less overshoot with better settling time than the conventional PI controller.

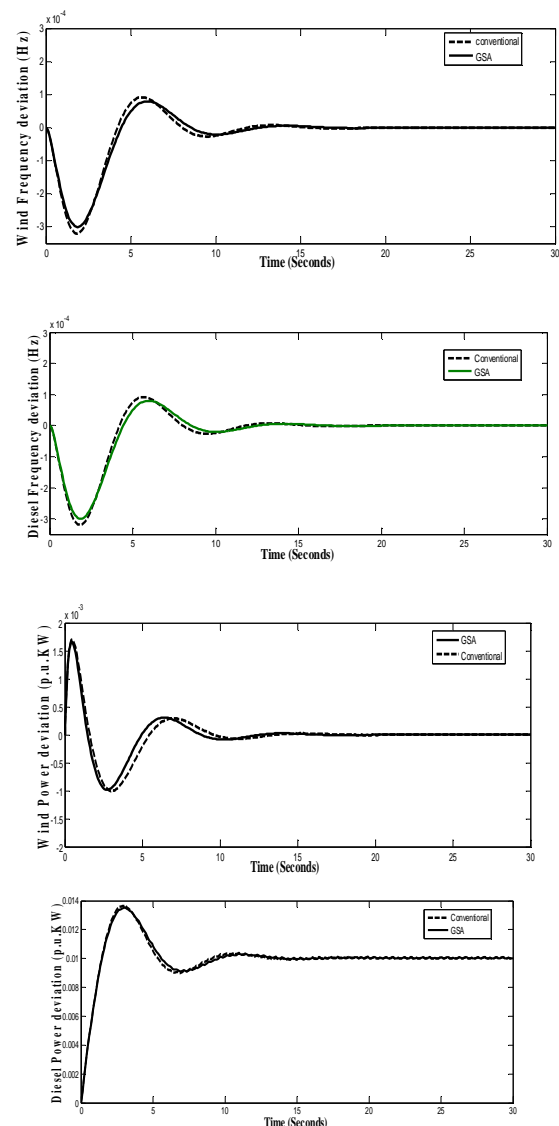

Fig.2. Closed loop responses of hybrid wind-biomass power system

VI. CONCLUSION

GSA based optimal design of pitch controller parameters has been developed for an isolated wind-biomass hybrid power system. The improvements in the quality of the transient response of frequency deviations for the hybrid wind-biomass power system have been achieved using a control which monitors the wind turbine and alters the pitch angle of the blades accordingly. From the results, it is observed that the proposed Controller performs better than the conventional PI controller.

VII. ACKNOWLEDGEMENT

The authors wish to thank the authorities of Annamalai University, Annamalainagar, Tamilnadu, India and the authorities of Tennessee Technological University, Cookeville, USA for the facilities provided to prepare this paper. The authors gratefully acknowledge Dr. P. K. Rajan, Interim Director of Center for Energy Systems Research and Dr. Joseph Olorunfemi Ojo, Professor of Electrical and Computer Engineering, Tennessee Technological University, USA for their valuable comments and suggestions.

REFERENCES

- [1] "Wind energy resource, wind energy conversion system modeling and integration: a survey, T.R. Ayodele* and A.S.O. Ogunjuyigbe, International Journal of Sustainable Energy, Taylor & Francis, 2013.
- [2] "Dynamics and stability of wind and biomass turbine generators with superconducting magnetic energy storage unit on an isolated power system", S.C.Tripathy M.Kalantar, R.Balasubramanian, IEEE Transactions on Energy Conversion, Vol. 6, No.4, December 1991. .
- [3] "Wind Turbine Generator Interaction with Diesel Generators on an Isolated Power System", G.W.Scott, V.F.Wilreker and R.K.Shaltens, IEEE Trans. on Power Apparatus and Systems, PAS-103, No.5, pp. 933-937, May 1984.
- [4] "Commissioning Tests of the Bonneville Power Administration 30 MJ Superconducting Magnetic Energy Storage Unit", H.J.Boenig and J.F.Hauer, IEEE Trans. on Power Apparatus and Systems. Vol.PAS-104, No. 2, pp. 302-312, February 1985.
- [5] "Application of Superconducting Magnet Energy Storage to Improve Power System Dynamic Performance", Y.Mitani, K.Tsuji and Murakami, IEEE Trans. on Power Systems, Vol. 3, No. 4, pp. 1418-1425, November 1988.
- [6] "GSA: A Gravitational Search Algorithm", Esmat Rashedi, Hossein Nezamabadi-pour and Saeid Saryazdi, Elsvier journal, pp.2232-2248, 2009.
- [7] "Design of dual mode linguistic hedge fuzzy logic controller for an isolated wind-diesel hybrid power system with CES unit", M.Mohamed Thameem Ansari and S.Velusami, Engineering Intelligent System, pp.211-235,2013.