

Simulation of Converter Control Strategy For A Sustainable Micro Grid Using Wind And PV Resources

Radhika.S

Assistant Professor, Dept of EEE
CKCET,CuddaloreCKCET,Cuddalore

Abstract- This project proposed a converter design and implementation of control strategy for a sustainable micro-grid using wind and solar energy. The proposed work is used to maintain the stability and to improve the performance and reliability of the system. This system can support both step up/down operation for each renewable source. This work focuses on the development of a supervisory model predictive control method for the optimal management and operation of hybrid wind-solar energy generation systems. The supervisory control system via MPC which computes the power references for the wind and solar subsystems at each sampling time while minimizing a suitable cost function. The proposed converter design is also used to reduce the ripple current.

Keywords- Model predictive control (MPC), photovoltaic (PV), direct current (DC), maximum power point tracking (MPPT), single ended primary inductor converter (SEPIC).

I. INTRODUCTION

The field of renewable energy is very popular in the recent years. Wind power as an important renewable energy source, it is plentiful, clean, produces no greenhouse gas emissions during operation, and it requires small land. The overall cost per unit of energy produced is equal to the cost for new coal and natural gas installations. Wind source is less problematic than any other energy source. Solar photovoltaic energy is also the most popular renewable energy technologies since it is available everywhere. A photovoltaic cell converts the sun light into the electric energy. Solar photovoltaic energy is mainly used for residential or industrial electrical systems.

Since photovoltaic cells are not very efficient, special interest must be taken into obtaining the maximum power that can be extracted from the photovoltaic cell for a given solar radiation. Therefore, one of the main research interests inside the photovoltaic energy technology is the maximum power point tracking. Maximum power point tracking for a given solar radiation is developed in this project. MPPT is an essential part of PV system. It functions as an optimal electric

load for a PV cell, and converts the power to a voltage or current level which is more suitable to whatever load the system is designed to drive. MPPT consists of DC-DC converter which limits power loss by matching the photovoltaic panel and the load impedances by varying the duty cycle of the switch used in the converter circuit.

The DC to DC converters used in this system are the SEPIC and Ćuk converters. There are several topologies, including Buck, Boost, Buck-Boost, SEPIC, Ćuk, Fly back, etc. Buck and Boost topologies allow decreasing and increasing of the output voltage respectively, while the Buck-Boost can do both functions. Fly back converter adds complexity and weight. Due to simplicity, maximum efficiency, low loss and safe operation mode of inductors, Ćuk and SEPIC converters were implemented in this project. The **Ćuk converter** is a type of DC-DC converter that has an output voltage magnitude that is either greater than or less than the input voltage and it can only have opposite polarity between input and output. **Single-ended primary-inductor converter (SEPIC)** is a type of DC-DC converter allowing the electrical potential (voltage) at its output to be greater than, less than, or equal to that at its input. A SEPIC is similar to a buck-boost converter and it having non-inverted output (the output voltage is same polarity as the input voltage).

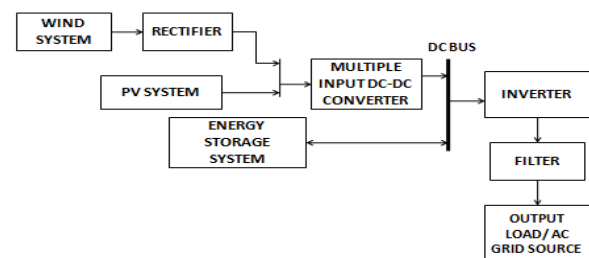

Fig. 1 Block diagram

Fig.1 shows the basic block diagram of the proposed system. Its main sources are wind and PV. Wind system is used to convert kinetic energy from the wind into electric current; it provides the alternating current that can be converted into direct current by using the rectifier. PV system

is an arrangement of components designed to supply usable electric power for a variety of purposes and its output is DC. These both DC can be integrated by the multiple input converter, which converts a source of direct current (DC) from one voltage level to another and the output of this converter is given to the main DC bus and the output of DC bus is given to the inverter, which changes direct current to alternating current and that is given to the AC grid.

II. SYSTEM DESCRIPTION

A. Master circuit

This paper proposed a supervisory control technique and the converter design.

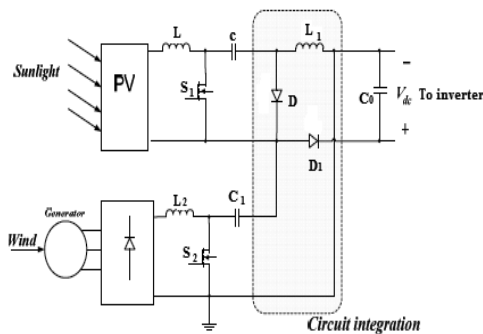

Fig.2 Proposed topology

Fig. 2 shows the master circuit of the proposed system, the converter gets the source from the solar and the wind system. The proposed DC-DC converters used in the system are SEPIC and cuk converter, here SEPIC converter is connected with the solar system and cuk converter is connected with the wind system. These both converters are integrated by the diode and the output of the converter is given to the DC bus.

In this paper proposed a supervisory control technique, the use of this controller is to minimize the cost of the system and to reduce the power consumption. This supervisory controller will activate the useful source and isolates the inefficient converter and its source.

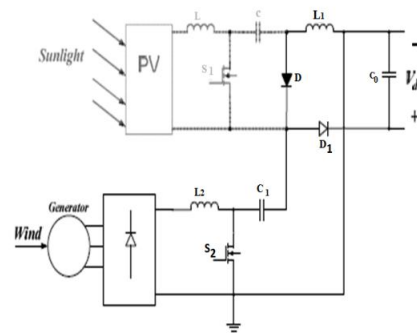

Fig.3 Only wind source is operational (SEPIC)

Fig. 3 shows the operation of SEPIC converter, here solar source is unavailable, in this case diode D turns off and diode D1 turns on, then the circuit becomes a SEPIC converter, that time wind source supplies the power to the converter.

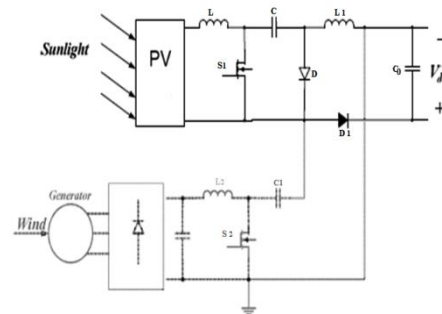

Fig.4 Only PV source is operational (Cuk)

Fig. 4 shows the operation of cuk converter, here wind source is not available, in this case diode D1 turns off and diode D on then the circuit becomes Cuk converter, that time PV source can supply the power to the converter.

III. CONTROL STRATEGIES

A. MPPT Controller

In this project, Maximum power point tracking is developed for a given solar radiation. It optimizes the power generated by the photovoltaic panel. Numerous algorithms followed to obtain the MPP. In this project Perturb and observe algorithm is used.

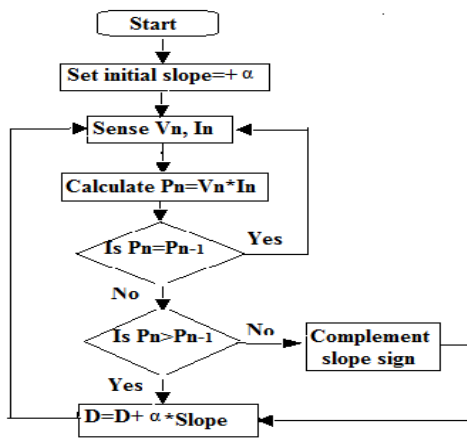

Fig. 5 Perturb and observe algorithm

B. Supervisory controller

The work of the supervisory control system is to determine the power references of the wind and solar subsystems at each sampling time. The power references are sent to two local controllers which drive the wind and solar subsystems to the desired power reference values. The primary control objective is to manipulate the operating points of the wind subsystem and of the solar subsystem together to generate enough energy to satisfy the demand. The objective of this control will be considered in the design of the cost function for the MPC optimization problem. The secondary control objective is to reduce the peak value of surge currents. This control objective will incorporate hard constraints in the MPC optimization problem to restrict the maximum increasing rates of the generated power of the two subsystems as well as a term in the cost function to avoid frequent discharge and charge of the battery bank.

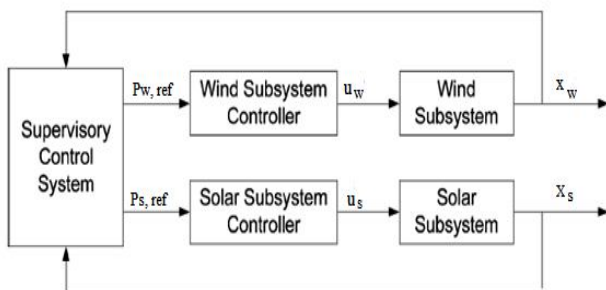

Fig. 6 Block diagram of Supervisory control system

The supervisory control system via model predictive control which computes the power references for the wind and solar subsystems at each sampling time while minimizing a cost. The power references are given to two local controllers which drive the wind and solar subsystems to the desired power reference values.

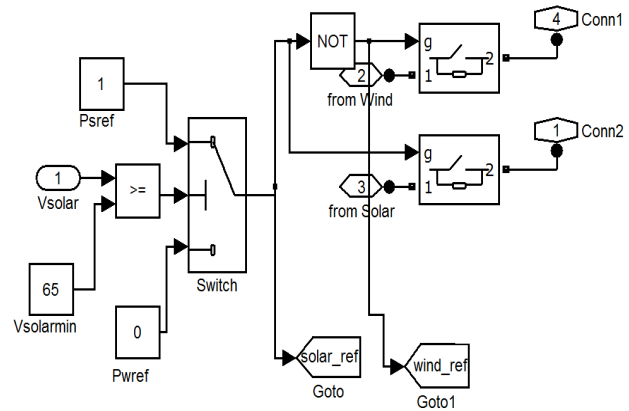

Fig. 7 Supervisory control circuit

Here minimum setting voltage is 65V and V_{solar} is an obtained voltage from the solar system. If the obtained voltage is lesser than the 65V that time the supervisory controller isolates the solar system it allows to operate only the wind system. If the obtained voltage is greater than 65V that time solar system is activated and wind system is deactivated.

IV. SIMULATION RESULTS

A. Parameter settings

PV Panel specifications

- Input voltage: 200 V
- Input power : 500W

Wind Specifications

- Input voltage: 400 V
- Input power : 500W

Multi-Input converter Specifications

- Inductor L1,L2: 2mH
- Capacitor C1,C2 : 300μF
- Filter inductor : 1mH
- Filter capacitor : 5μF
- Line voltage :220V
- Line frequency :50 Hz
- Output filter capacitor: 470μF
- Output filter inductor: 2 mH
- DC link capacitor: 2200μF
- DC link voltage :360V

B. Existing system

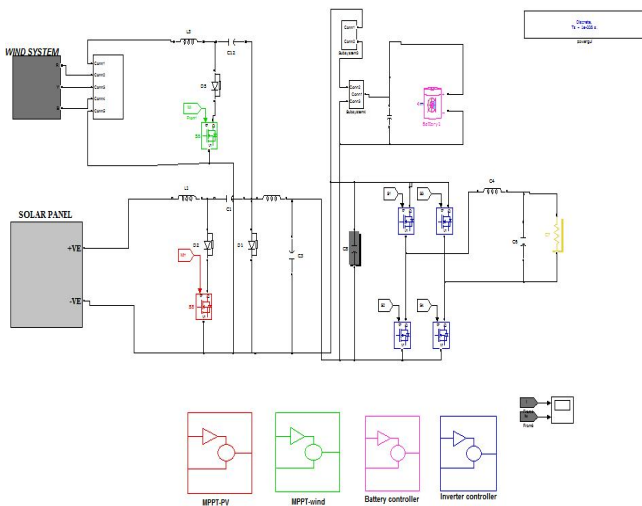

Fig. 8 Simulation circuit of Existing system

Here DC link voltage is maintained as 360V to get inverter output as 220V, wind system supplies the voltage of 400 but to maintain 360V in DC link cuk converter which is connected with wind source is acting as buck converter. Similarly PV voltage is 200V to maintain 360V in DC link the cuk converter is acting as boost converter. Here both the converter is operating simultaneously so operating cost and power consumption will be more to overcome this proposed system is implemented.

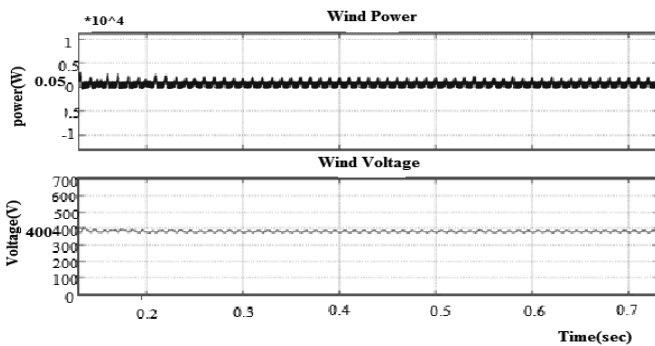

Fig. 9 Wind Power and Voltage of existing system

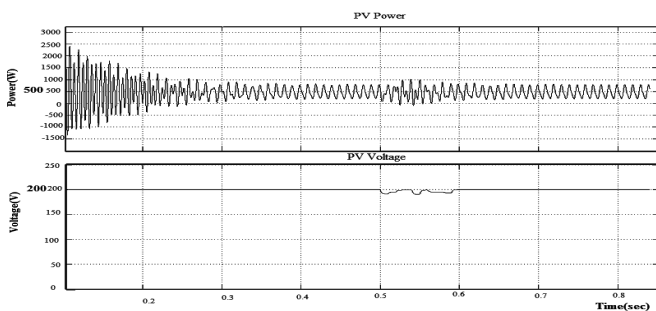

Fig.10 PV Power and Voltage of existing system

C. Proposed system

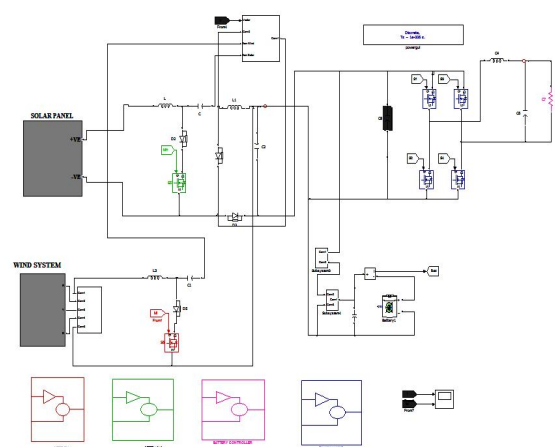

Fig.11 Hybrid system with Sepic-Cuk integrated converter

In proposed system supervisory controller is used for the optimal management of hybrid sources, and cuk-sepic converter is used to reduce the ripple current. The supervisory controller isolates the inefficient converter and its source; it allows operating only the efficient converter so the operating cost of the inefficient converter can be reduced.

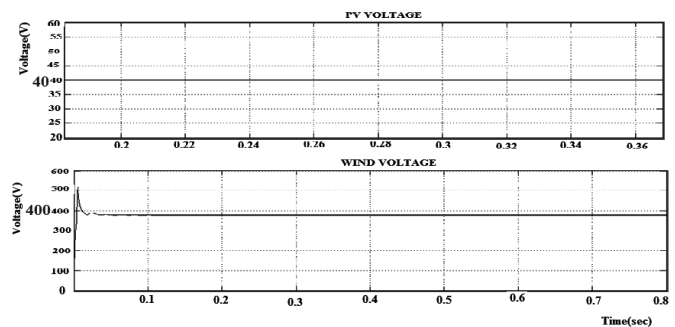

Fig. 12PV Voltage and Wind Voltage of proposed system

In supervisory controller the setting minimum voltage is 65V, here obtained PV voltage is lesser than 65V so the supervisory controller isolates the PV source and activates the wind source.

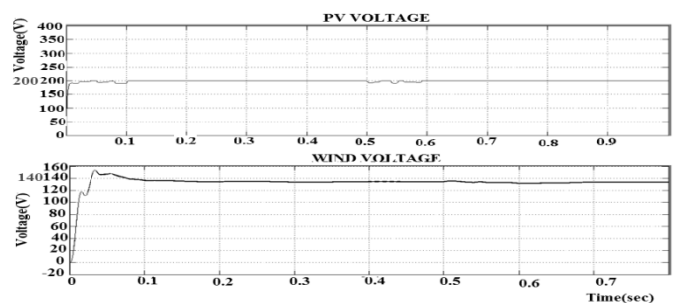

Fig.13 PV Voltage and Wind Voltage of proposed system

Here obtained PV source is greater than 65V so the supervisor controller allows the PV system and the converter

which is connected to the PV system is operating, here PV gives 200V so that converter is acting as boost converter. In this case the supervisory controller isolates the wind system.

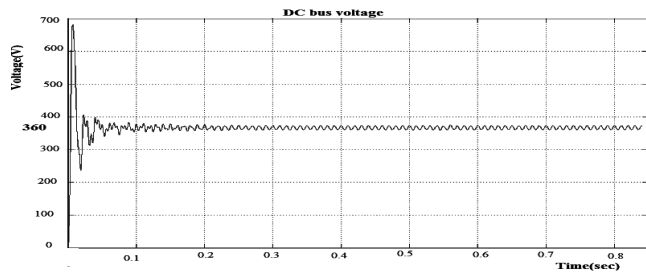

Fig.14 DC Link Voltage

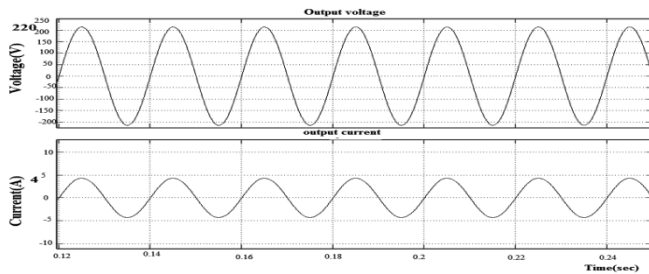

Fig. 15 Inverter Output Voltage and Current

d. Comparison of Output

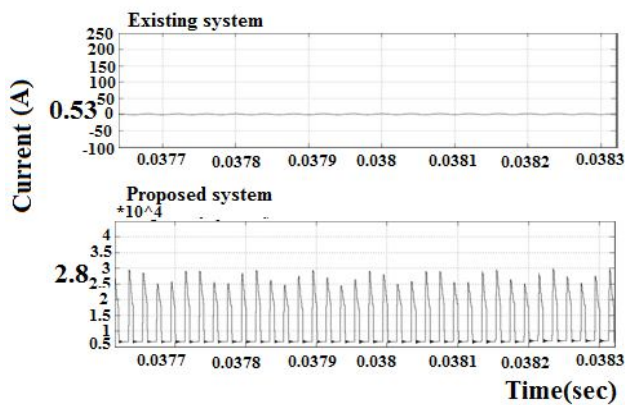

Fig. 16 Converter ripple current (PV)

In existing system the ripple current of the converter which is connected with the PV source is 0.53A, it is further reduced into 2.8mA in the proposed system.

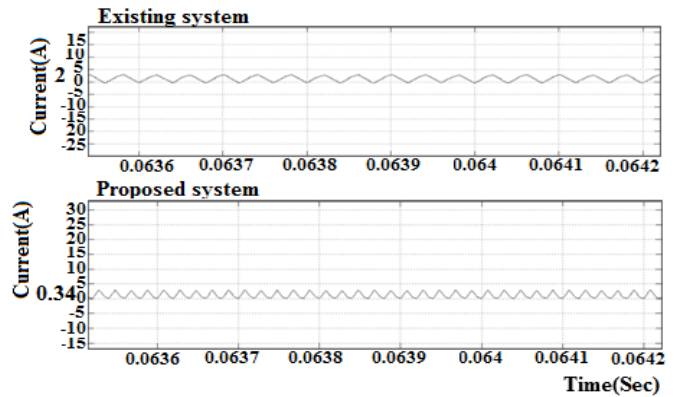

Fig. 17 Converter ripple current (Wind)

The converter ripple current (wind) in the existing system is 2A, which is reduced into 0.34A in the proposed system.

e. Tabulation

PARAMETER S	EXISTING SYSTEM	PROPOSED SYSTEM	
		Wind active	PV active
Wind Voltage	400V	400V	140V
PV Voltage	200V	40V	200V
PV Power	500W	0.07W	500W
Wind Power	500W	500W	0.37W
Converter ripple current (PV)	0.53A	2.8mA	
Converter ripple current (wind)	2A	0.34A	

Table.1 Comparison of Output

V. CONCLUSION

Thus a hybrid micro grid is proposed and comprehensively studied in this project. The supervisory predictive control method for the optimal management and operation of hybrid wind-solar energy generation systems were developed. Proposed a supervisory control system via MPC which computes the power references for the wind and solar subsystems at each sampling time while minimizing a cost. The power references are given to two local controllers which drive the two subsystems to the power references. Simulation results demonstrated the effectiveness and applicability of the proposed approach.

REFERENCES

[1] Anderson.P.Mand Bose.A, (1983) ‘Stability simulation of wind turbine systems,’ IEEE Trans. Power Appl. Syst., vol. PAS-102, no. 12, pp. 3791–3795.

- [2] Kwasinski.A, (2011) ‘Quantitative evaluation of DC microgrids availability: Effects of system architecture and converter topology design choices,’ IEEE Trans. Power Electron., vol. 26, no. 3, pp. 835–851.
- [3] Kwasinski.A, (2010) ‘Technology planning for electric power supply in critical events considering a bulk grid, backup power plants, and micro grids,’ IEEE Syst. J., vol. 4, no. 2, pp. 167–178.
- [4] Khaligh.A, Jian.C and Young-Joo.L, (2009) ‘Multiple input DC-DC converter topology,’ IEEE Trans. Power Electron, vol.24, no 3, pp. 862-868.
- [5] Liu.C, Chau.K.T and Xiaodong.Z, (2010) ‘An efficient wind-photovoltaic hybrid generation system using doubly excited permanent-magnet brushless machine,’ IEEE Trans. Ind. Electron., vol. 57, no. 3, pp. 831–839.
- [6] Matsuo.H, Wenzhong.L, Kurokawa.F, Shigemizu.T, and Watanabe.N, (2004) ‘Characteristics of the multiple-input DC-DC converter,’ IEEE Trans. Ind. Electron., vol. 51, no. 3, pp. 625–631.
- [7] Mohan.N, Underland.T, and Robbins.W, (2003) ‘Power Electronics; Converters, Applications, and Design,’ 3rd ed. Hoboken,NJ:Wiley.
- [8] Patel.M.R, (1999) ‘Wind and Solar Power Systems’, Boca Raton, FL: CRC Press.
- [9] SungwooBae, and Alexis Kwasinski, (2012) ‘Dynamic Modeling and Operation Strategy for a MicrogridWith Wind and Photovoltaic Resources’, IEEE Transaction on Smart Grid, vol. 3, no. 4.
- [10] Villalva.M.G, Gazoli.J.R, and Filho.E.R, (2009), ‘Comprehensive approach to modeling and simulation of photovoltaic arrays,’ IEEE Trans. Power Electron., vol. 24, no. 5, pp. 1198–1208.
- [11] Valenciaga.F and Puleston.P.F, (2005) ‘Supervisor control for a stand-alone hybrid generation system using wind and photovoltaic energy,’ IEEE Trans. Energy Convers., vol. 20, no. 2, pp. 398–405.
- [12] Wenkai.W, Pongratananukul.N, Weihong.Q, Rustom.K, Kasparis.T, and Batarseh.I, (2003) ‘DSP-based multiple peak power tracking for expandable power system,’ in Proc. IEEE 18th APEC, pp. 525–530.

BIOGRAPHY

S.Radhika, born in 1983, is presently Assistant professor of Electrical and Electronics Engineering Department, CK College of Engineering and Affiliated under Anna University, Chennai. She obtained B.E from Madras University, M.E from Mailam engineering College which is affiliated to Anna University. ksradhi_83@yahoo.co.in