

Simulation and Performance Evaluation of Exhaust Gas Recirculation (EGR) Using Nano-Fluids

GM Naveed¹, V.K.Pravin²

¹Dept of Thermal power Engineering

² Professor, Dept of Mechanical Engineering

^{1,2} PDA College of Engineering, Kalaburagi Karnataka, India

Abstract- A numerical model is developed to predict the performance of an exhaust gas recirculation (EGR) using Nano fluids as the coolant. The model accounts for turbulent flow of coolant and hot smokes on an integrated computational domain. Thermal and hydrodynamic behavior of Nano fluids comprising water as base fluid and Al₂O₃ nanoparticles, were compared over a wide range of Reynolds numbers and various particles concentrations. The accuracy of prediction was verified by experimental data available in the literature. The Al₂O₃- water Nano fluids was found to provide the greatest heat transfer enhancement. Quantitatively, Al₂O₃-water Nano fluid with a volume fraction of 5% and Reynolds number of 5000 improves the heat transfer coefficient by about 16% compared to pure water. However, it was found that the heat transfer enhancement was achieved at the expense of increased pressure due to greater viscosity of Nano fluids compared to the base paper.

Keywords- EGR, diesel exhaust gas, Nano fluid, numerical simulation.

I. INTRODUCTION

Emissions from internal combustion engines have a major role in environmental pollution. Engine exhaust gases release many dangerous pollutants to the atmosphere including nitrogen oxide (NO_x) which has carcinogenic effects. Exhaust gas recirculation (EGR) coolers are heat exchangers that reduce the NO_x emission by decreasing the temperature of the hot exhaust recirculated gases. The schematic diagram of an EGR cooler is depicted in Fig. 1. As shown in the figure, hot engine exhaust smokes run through the tubes and the coolant flows in the shell side in an arbitrary direction. After cooling process, a portion of gases recirculates to the combustion chamber and its temperature decreases. Therefore, the generation of NO_x diminishes due to the low temperature of the combustion gases [1]. In other methods, additional fuel is injected into the combustion chamber in order to achieve a richer mixture that results in smaller temperature rise and NO_x generation without loss of power. However, this approach, increases emission of CO and CO₂ and also increases the engine fuel consumption [2]. Temperature reduction of

exhaust gases also helps to prevent the melting of catalyst coating which traps soot and reduces harmful emissions from diesel

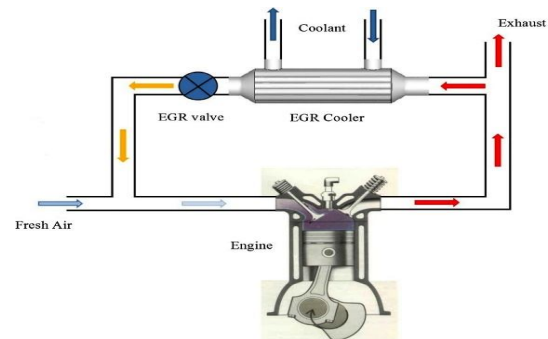

Exhausts.

More efficient coolants like Nano fluids, can increase the efficiency of cooling process, and allow for the use of smaller heat exchangers. Nano fluids with metallic particles have been considered as candidate heat transfer fluids with superior heat transfer [3]. Over the past few years, many theoretical and experimental studies have been conducted on convection heat transfer of Nano fluids in laminar and turbulent flow regimes. Pak and Cho found that increasing nanoparticle concentration led to improved heat transfer coefficients. Xuan and Li [5] presented a correlation for Nusselt number as a function of particle concentration. Besides experimental studies, numerical simulations have been employed to analyze the heat transfer behavior of Nano fluids [6–11]. Nano fluids flow can be modeled using two different approaches. In the first approach, Nano fluids are considered as a composition of two separate phases including base fluid and nanoparticles. Therefore it is possible to study the role of each phase in the heat transfer process. In the second approach, the mixture of the base fluid and nanoparticles is considered as a single phase fluid with effective thermophysical properties. It should be noted that in the second approach both phases are assumed to be in thermal equilibrium and share the same flow field. The simplicity and the less computational cost associated with the

Latter approach come with the penalty of less accurate predictions compared to the former approach.

Behzadmehr et al. [12] performed a two-phase simulation of turbulent flow of Nano fluids in tube using mixture model. Results of the other two-phase simulations proved the superiority of thermal properties of Nano fluids in comparison with the base fluids [13–15]. Furthermore, Bianco et al. [16]

Showed that at high Reynolds number and low nanoparticle concentration, single phase simulations have acceptable accuracy in Nano fluids simulations. Several studies investigated the efficiency of Nano fluids as a coolant in heat exchangers. The results suggested that in industrial heat exchangers, especially in turbulent flows, substituting traditional fluids by Nano fluids does not provide any advantage [17]. The outstanding property of Nano fluids made the authors to investigate the effect of substitution of these fluids in EGR coolers. For example Kim et al. [18] considered the effect of carbon Nano fluid on the cooling performance of an EGR Cooler. They found a little improvement in the cooling performance of Nano fluid than that of water.

In this study, Nano fluids with different particle concentrations at various Reynolds numbers are investigated numerically for use as heat transfer fluid of an EGR cooler. First, both the two phase mixture model and single phase model are used for the simulation of Nano fluid flow in a circular tube with uniform heat flux on the wall. The Nusselt numbers obtained using both models are compared at different Reynolds numbers for various tube wall temperatures. The proposed numerical model of an EGR cooler is validated by comparison with experimental data related to a double pipe heat exchanger. Finally, the performance of Nano fluids coolants is studied by a 3D numerical model (both exhaust gases and coolant side) of an EGR cooler.

Computational Fluid Dynamics (CFD) has grown from a mathematical curiosity to become an essential tool in almost every branch of fluid dynamics, from aerospace propulsion to weather prediction. CFD is commonly accepted as referring to the broad topic encompassing the numerical solution, by computational methods. These governing equations, which describe fluid flow, are the set of Navier-Stokes equation, continuity equation and any additional source terms, for example, porous medium or electric body force.

Since the advent of the digital computer, CFD, as a developing science, has received extensive attention throughout the international community. The attraction of the subject is twofold. Firstly, there is the desire to be able to model physical fluid phenomena that cannot be easily simulated or measured with a physical experiment, for

example, weather systems. Secondly, there is desire to be able to investigate physical fluid systems more cost effectively and more rapidly than with experimental procedures.

Traditional restrictions in flow analysis and design limit the accuracy in solving and visualization of the fluid-flow problems. This applies to both single and multi-phase flows, and is particularly true of problems that are three dimensional in nature and involve turbulence, additional source terms, and/or heat and mass transfer. All these can be considered together in the application of CFD, a powerful technique that can help to overcome many restrictions inherent in traditional analysis.

CFD is a method for solving complex fluid flow and heat transfer problems on a computer. CFD allows the study of problems that are too difficult to solve using classical techniques. The flow inside the ESP is complex and this can be analyzed using CFD tool, which provides an insight into the complex flow behavior.

II. CFD SIMULATIONS

The process of performing CFD simulations is split into three components:

- Preprocessing
- Solving
- Post Processing

The pre-processor contains all the fluid flow inputs for a flow problem. It can be seen as a user-friendly interface and a conversion of all the input into the solver in CFD program. At this stage, quite a lot of activities are carried out before the problem is being solved. These stages are listed below:

Geometry Definition - The region of interests that is the computational domain which has to be defined.

Grid generation- It is the process of dividing the domain into a number of smaller and non-overlapping sub-domains.

Physical and chemical properties - The flow behavior in terms of physical and chemical characteristics are to be selected.

Fluid property Definition - The fluid properties like density and viscosity are to be defined.

Boundary conditions - All the necessary boundary conditions have to be specified on the cell zones.

The solution of the flow problem such as temperature, velocity, pressure etc. is defined at the nodes inside each cell. The accuracy of the CFD solution is governed by the number of cells in the grid and is dependent on the fineness of the grid.

Solution

In the numerical solution technique, there are three different streams that form the basis of the solver. They are finite difference, finite element and finite volume methods. The differences between them are the way in which the flow variables are approximated and the discretization processes are done.

1. Finite Difference Method (FDM)

FDM describes the unknown flow variables of the flow problem by means of point samples at node points of a grid coordinate. By FDM, the Taylor's expansion is usually used to generate finite differences approximation.

2. Finite Element Method (FEM)

FEM uses the simple piecewise functions valid on elements to describe the local variations of unknown flow variables. Governing equation is precisely satisfied by the exact solution of flow variables. In FEM, residuals are used to measure the errors.

3. Finite Volume Method (FVM)

FVM was originally developed as a special finite difference formulation. The commercial CFD code packages using the FVM approaches are PHOENICS, FLUENT, FLOW 3D and STAR-CD. Basically, the numerical algorithm in these CFD commercial packages involves the formal integration of the governing equation over all the finite control volume, the discretization process involves the substitution of a variety of FDM types to approximate the integration equation of the flow problem, and the solution is obtained by iterative method. Discretization in the solver involves the approaches to solve the numerical integration of the flow problem. Usually, two different approaches are made, one at a time.

Explicit approach: Usually, this is the most useful approach that makes sense. It is relatively simple to set up and program. The limitation is that for a given t and x , the time must be less than some limit imposed by stability constraints. In some cases, t must be very small to maintain the stability, and consequently long running time is required for the calculation over a given time interval t .

Implicit approach: For this approach, the stability can be maintained over a large value of t and fewer time steps are required for making calculation resulting in less computer time. But it is complicated to set up and program. The computer time per time step is much larger than the explicit approach due to the matrix manipulation, which is required for each time step. This approach is very accurate to follow the exact transients, i.e., the time variations of the independent variables.

Post-Processing

The CFD package provides the data visualization tools to visualize the results of the flow problem. This includes – vectors plots, domain geometry and grid display, line and shaded counter plots, particle tracking etc. Recent facilities are aided with animation for dynamic result display and they also have data export facilities for further manipulation external to the code.

Determining the convergence, whether the solution is consistent and stable for all range of flow variables, is important.

Convergence is a property of a numerical method to produce a solution that approaches the exact solution by which the grid spacing and control volume size are reduced to a specific value or to zero value.

Consistency is to produce the system of algebraic equations that can be equivalent to the original governing equation.

Stability associates with the damping of errors as a numerical method proceeds. If a technique chosen is not stable, even the round-off error in the initial data can lead to wild oscillations or divergence.

III. GOVERNING EQUATIONS

Conservation Law

Navier-Stokes equations are the governing equations of Computational Fluid Dynamics. It is based on the conservation law of physical properties of fluid. The principle of conservation law is the change of properties, for example mass, energy, and momentum, in an object is decided by the input and output.

For example, the change of mass in the object is as follows

$$\frac{dM}{dt} = \dot{m}_{in} - \dot{m}_{out} \tag{1}$$

If $\dot{m}_{in} - \dot{m}_{out} = 0$, we have

$$\frac{dM}{dt} = 0 \tag{2}$$

Which means

$$M = const \tag{3}$$

Navier-Stokes Equation

Applying the mass, momentum and energy conservation, we can derive the continuity equation, momentum equation and energy equation as follows.

Continuity Equation

$$\frac{D\rho}{Dt} + \rho \frac{\partial U_i}{\partial x_i} = 0 \tag{4}$$

Momentum Equation

$$\underbrace{\rho \frac{\partial U_j}{\partial t}}_I + \underbrace{\rho U_i \frac{\partial U_j}{\partial x_i}}_{II} = - \underbrace{\frac{\partial P}{\partial x_j}}_{III} - \underbrace{\frac{\partial \tau_{ij}}{\partial x_i}}_{IV} + \underbrace{\rho g_j}_V \tag{5}$$

Where

$$\tau_{ij} = -\mu \left(\frac{\partial U_j}{\partial x_i} + \frac{\partial U_i}{\partial x_j} \right) + \frac{2}{3} \delta_{ij} \mu \frac{\partial U_k}{\partial x_k} \tag{6}$$

- I: Local change with time
- II: Momentum convection
- III: Surface force
- IV: Molecular-dependent momentum exchange (diffusion)
- V: Mass force

Energy Equation

$$\underbrace{\rho c_\mu \frac{\partial T}{\partial t}}_I + \underbrace{\rho c_\mu U_i \frac{\partial T}{\partial x_i}}_{II} = - \underbrace{P \frac{\partial U_i}{\partial x_i}}_{III} + \underbrace{\lambda \frac{\partial^2 T}{\partial x_i^2}}_{IV} - \underbrace{\tau_{ij} \frac{\partial U_j}{\partial x_i}}_V \tag{7}$$

- I: Local energy change with time
- II: Convective term
- III: Pressure work
- IV: Heat flux (diffusion)
- V: Irreversible transfer of mechanical energy into heat

If the fluid is compressible, we can simplify the continuity equation and momentum equation as follows.

Continuity Equation

$$\frac{\partial U_i}{\partial x_i} = 0 \tag{8}$$

Momentum Equation

$$\rho \frac{\partial U_j}{\partial t} + \rho U_i \frac{\partial U_j}{\partial x_i} = - \frac{\partial P}{\partial x_j} - \mu \frac{\partial^2 U_j}{\partial x_i^2} + \rho g_j \tag{9}$$

General Form of Navier-Stokes Equation

To simplify the Navier-Stokes equations, we can rewrite them as the general form.

$$\frac{\partial(\rho\Phi)}{\partial t} + \frac{\partial}{\partial x_i} \left(\rho U_i \Phi - \Gamma_\Phi \frac{\partial \Phi}{\partial x_i} \right) = q_\Phi \tag{10}$$

When $\Phi = 1, U_j, T$, we can respectively get continuity equation, momentum equation and energy equation.

IV. SCOPE OF THE PRESENT WORK

The LHR engines are energy efficient engines with respect to energy conversion. Due to dynamic conditions of the internal combustion engine, the high energy release in an LHR engine cannot be fully realized as work done and higher amount of energy is going in the exhaust as a waste heat. To realize the energy available in the exhaust, the LHR concept is introduced to the turbocharged engine, so that the heat can be utilized in the turbocharger for the effective compression of intake air. In addition to this, the extended expansion concept has also been introduced to realize in-cylinder work done to a higher level. Any engine which is going for higher percentage of combustion will result in higher amount of NO_x emission. In order to reduce the value of NO_x emission inside the engine cylinder during combustion the iEGR was introduced for the analysis.

methods. Main focuses are the effects are the behavior of gases in cooling condition with nano fluids to determine the accurate recommendation of process to define and solve the problem in exhaust gas recirculation.

V. MESHING

ANSYS Meshing is a general-purpose, intelligent, automated high-performance product. It produces the most appropriate mesh for accurate, efficient multi physics solutions. A mesh well suited for a specific analysis can be generated with a single mouse click for all parts in a model. Full controls over the options used to generate the mesh are available for the expert user who wants to fine-tune it. The power of parallel processing is automatically used to reduce the time you have to wait for mesh generation.

Table 1 Mesh Details

Statistics	
Nodes	
Elements	288255
Mesh Metric	1356437
	None

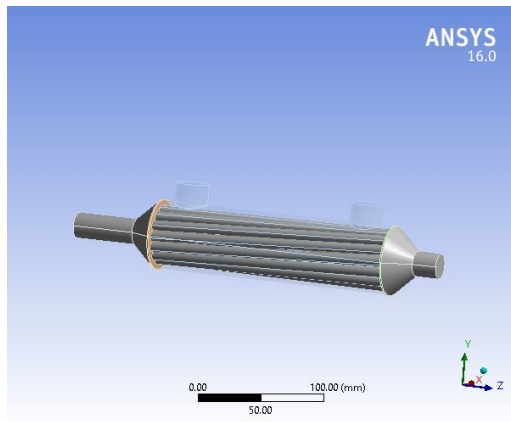

Fig 2 Geometry

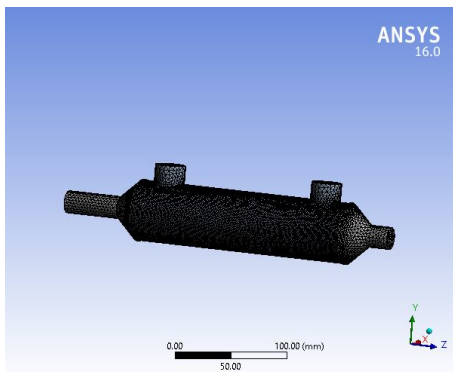

Fig 3 Discretized volume Mesh

VI. RESULTS AND DISCUSSION

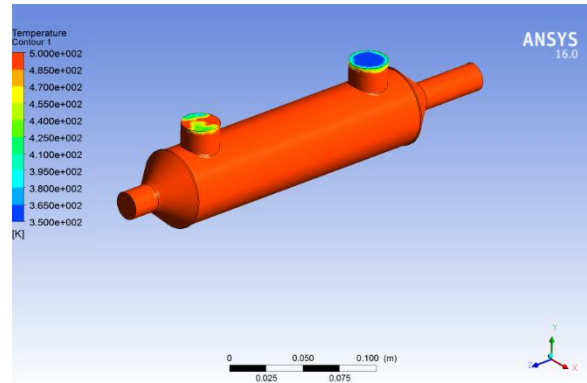

Fig 4 Temperature Distribution of The EGR cooler

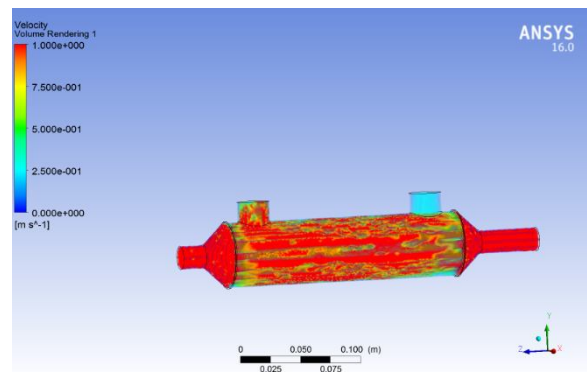

Fig 5 Velocity Distribution of EGR Cooler

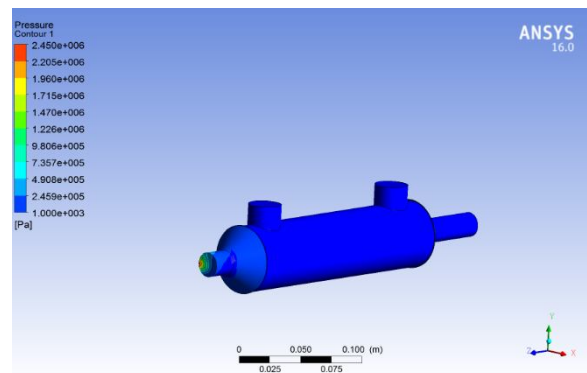

Fig 6 Pressure Distribution of EGR cooler

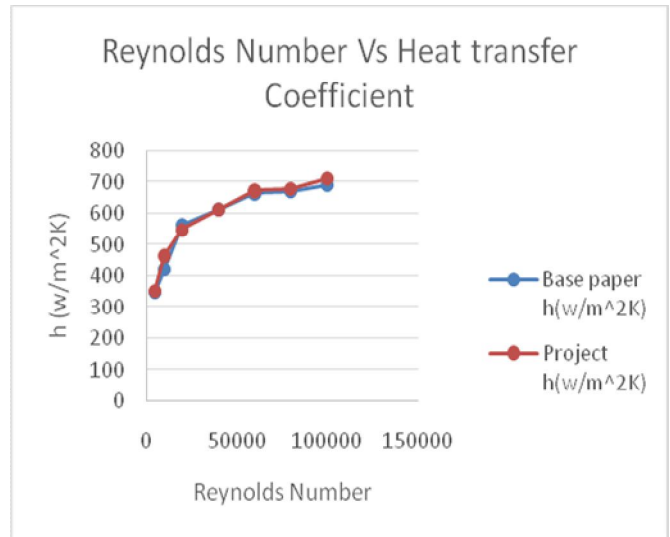
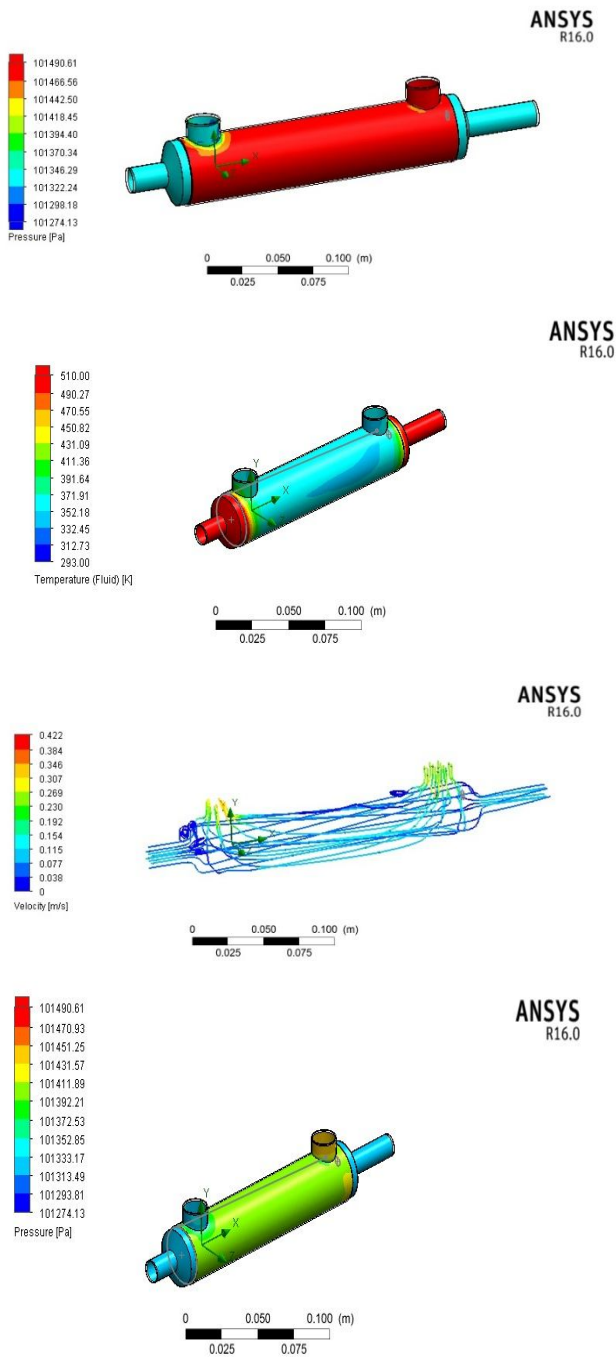

Fig 7 Reynolds number Vs heat transfer Coefficient

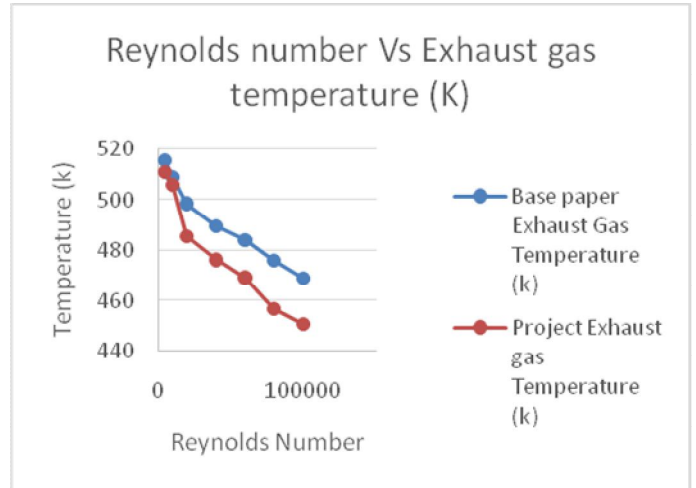

Fig 8 Reynolds number VS nusselt number

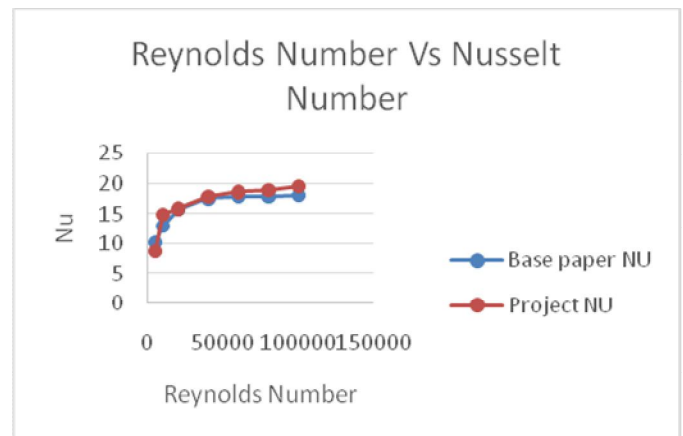

Fig 9 Renolds number Vs Nusselt Number

Averaged temperature of tube walls is sketched in different Reynolds number in Fig. 7. With the increment of coolant flow rate the separator wall temperature tended to a minimum value (cool-ant temperature) and maximum heat

transfer rate occurred between hot and cold fluids. After this point increasing in the coolant flow rate or using more efficient coolants like Nano fluids only led to the greater power consumption of the water pump and has no significant impact on the cooling of the hot gases. This issue was observed in [Fig. 8](#) where the temperature of exhaust gases at EGR cooler outlet was presented.

In the cooling systems presence of metallic nanoparticles caused some pressure drop and directly affected the required power of Nano fluid recirculation through the cooling circuit. In this regard, the graph of Nano fluids pressure drop against Reynolds number is depicted in [Fig. 9](#). As it expected, increasing in Reynolds number increases pressure drop for all of Nano fluids. In contrast with [Fig. 6](#), as the Reynolds number increases the pressure drop grows in an exponential manner. Moreover it seems for Reynolds numbers greater than 60,000, using Nano fluids makes no remarkable improvement in cooling system heat transfer rate while a considerable pressure drop occurs under these conditions.

[Fig. 10](#) shows the effect of Al_2O_3 nanoparticles volume fraction on the heat transfer coefficient versus Reynolds number. It could be observed that, heat transfer coefficient was directly proportional to the volume fraction of nanoparticles. It is clear in the figure that unlike high Reynolds numbers the effect of the

VII. CONCLUSIONS

In this paper the turbulent flow of water based Nano fluids inside an exhaust gas recirculation (EGR) cooler was numerically simulated and its thermal and hydrodynamic behaviors were studied. At first a simple flow inside a uniformly heated tube was simulated using single phase and two-phase mixture models. Results proved that in turbulent flows, dilute Nano fluids may be approximated as a single phase fluid. After verification, the single phase model was served in order to consider the performance of Nano fluids as more efficient coolants in EGR coolers. Numerical model of the EGR cooler was validated with experimental results. Four different types of Nano fluids, consisting of water as base fluid and, Al_2O_3 nanoparticles were compared together and appropriate coolant was selected (Nano fluid of aluminum oxide). Necessary simulations carried out in different nanoparticle concentration and flow rate of Nano fluids. According to the results, the heat transfer always improved as the Reynolds number increased, but it associated with an increase of pump power. More-over it was found that utilizing of Nano fluids in EGR coolers was advisable in low Reynolds numbers. In highly turbulent flows, due to the imposition of excessive pressure drop and no sensible improvement in

thermal performance of EGR cooler, the substitution of conventional coolants by Nano fluids seems unpromising. To reduce that we have introduced the inclination of 4 degree tubes to enhance the temperature related parameters for better result

REFERENCES

- [1] H.M. Kim, S.K. Park, Investigation on the flow and heat transfer characteristics of diesel engine EGR Coolers, *Int. J. Automotive Technol.* 9 (2008) 149–153.
- [2] S. Lee, C. Bae, Design of a heat exchanger to reduce the exhaust temperature in a spark ignition engine, *Int. J. Therm. Sci.* 47 (2008) 468–478.
- [3] S. KaKac, A. Pramuanjaroenkij, Review of convective heat transfer enhancement with Nano fluids, *Int. J. Heat Mass Transfer* 52 (2009) 3187–3196.
- [4] B.C. Pak, Y. Cho, Hydrodynamic and heat transfer study of dispersed fluids with submicron metallic oxide particles, *Exp. Heat Transfer* 11 (1998) 151–170.
- [5] Y. Xuan, Q. Li, Investigation on convective heat transfer and flow features of Nano fluids, *J. Heat Transfer* 125 (2003) 151–155.
- [6] J.S. Palm, G. Gilles Roy, C. Nguyen, Heat transfer enhancement with the use of Nano fluids in radial flow cooling systems considering temperature-dependent properties, *Appl. Therm. Eng.* 26 (2006) 2209–2218.
- [7] R. Lotfi, Y. Saboohi, A.M. Rashidi, Numerical study of forced convective heat transfer of Nano fluids: comparison of different approaches, *Int. Commun. Heat Mass Transfer* 37 (2010) 74–78.
- [8] S. Allahyari, A. Behzadmehr, S.M. Hosseini Sarvari, Conjugate heat transfer of laminar mixed convection of a Nano fluid through an inclined tube with circumferentially non-uniform heating, *Nanoscale Res. Lett.* 6 (2011) 1–13.
- [9] Y. Yang, F. Lai, Numerical study of heat transfer enhancement with the use of Nano fluids in radial flow cooling system, *Int. J. Heat Mass Transfer* 53 (2010) 5895–5904.
- [10] J. Choi, Y. Zhang, Numerical simulation of laminar forced convection heat transfer of Al_2O_3 –water Nano fluid in a pipe with return bend, *Int. J. Therm. Sci.* 55 (2012) 90–102.
- [11] A.A. Rabienataj Darzi, M. Farhadi, K. Sedighi, S. Allahyari, M. Aghajani Delavar, Turbulent heat transfer of Al_2O_3 –water Nano fluid inside helically corrugated tubes: numerical study, *Int. Commun. Heat Mass Transfer* 41 (2013) 68–75.
- [12] A. Behzadmehr, A. Saffar-Avval, M. Galanis, Prediction of turbulent forced convection of a Nano fluid in a tube

- with uniform heat flux using a two-phase approach, *Int. J. Heat Fluid Flow* 28 (2007) 211–219.
- [13] B. Chun, H. Kang, S. Kim, Effect of alumina nanoparticles in the fluid on heat transfer in double-pipe heat exchanger system, *Korean J. Chem. Eng.* 25 (2008) 966–971.
- [14] A. Mirmasoumi, A. Behzadmehr, Numerical study of laminar mixed convection of a Nano fluid in a horizontal tube using two-phase mixture model, *Appl. Therm. Eng.* 77 (2008) 717–727.
- [15] V. Bianco, F. Chiacchio, O. Manca, S. Nardini, Numerical investigation of Nano fluids forced convection in circular tubes, *Appl. Therm. Eng.* 29 (2009) 3632–3642.
- [16] V. Bianco, O. Manca, S. Nardini, Numerical investigation on Nano fluid turbulent convection heat transfer inside a circular tube, *Int. J. Therm. Sci.* 25 (2010) 1–9.
- [17] M.N. Pantzali, A.A. Mouza, S.V. Paras, Investigating the efficacy of Nano fluids as coolants in plate heat exchangers (PHE), *Chem. Eng. Sci.* 64 (2009) 3290–3300.
- [18] S. Kim, H. Chung, H. Jeong, B. Lee, B. Ochirkhuyag, J. Lee, H. Choi, The study of heat transfer for Nano fluid with carbon nano particle in an exhaust gas recirculation (EGR) cooler, *Heat Mass Transfer* 49 (2013) 1051–1055.
- [19] B.E. Launder, D.B. Spalding, *Lectures in Mathematical Models of Turbulence*, Academic Press, London, England, 1972.
- [20] N. Sohrabi, N. Masoumi, A. Behzadmehr, S.M.H. Sarvari, A simple analytical model for calculating the effective thermal conductivity of Nano fluids, *Heat Transfer-Asian Res.* 39 (2010) 141–150.
- [21] N. Masoumi, N. Sohrabi, A. Behzadmehr, A new model for calculating the effective viscosity of Nano fluids, *J. Phys. D Appl. Phys.* 42 (2009) 1–6.
- [22] S.E.B. Maiga, N. Cong Tam, N. Galanis, G. Roy, T. Mare, M. Coqueux, Heat transfer enhancement in turbulent tube flow using Al_2O_3 nanoparticle suspension, *Int. J. Numer. Methods Heat Fluid Flow* 16 (2006) 275–292.
- [23] W. Duangthongsuk, S. Wongwises, Heat transfer enhancement and pressure drop characteristics of TiO_2 -water Nano fluid in a double-tube counter flow heat exchanger, *Int. J. Heat Mass Transfer* 52 (2009) 2059–2067

ABOUT AUTHORS

GM NAVEED

Perceived B.E degree in Mechanical Engineering from VTU Belgavi, Karnataka, India. Pursuing M.Tech degree in Thermal Power Engineering from PDA College of Engineering Kalaburagi, Karnataka, India.

V.K.PRAVIN

Professor, Department of Mechanical Engineering, PDA College of Engineering Kalaburagi, Karnataka, India