

Medical Image Analysis and Compression using Hybrid Wavelet Transform and Arithmetic coding

Vishal Tamrakar¹, Mr. Chandrashekhar Kamargaonkar², Dr. Monisha Sharma³

^{1, 2, 3} Department of Electronics & Telecommunication Engineering

^{1, 2, 3} Shri Shankaracharya Technical Campus (SSTC), SSGI (FET), Junwani Bhilai C.G

Abstract- Medical imaging is on the best method for monitoring the patient health condition. CT or MRI medical imaging produces digital form of human body pictures. There exists a need for compression of these images for storage and communication purposes. Current compression schemes provide a very high compression rate with a considerable loss of quality. In medicine, it is necessary to have high image quality in region of interest, i.e. diagnostically important regions. This work discusses a hybrid model of lossless compression in region of interest with high compression rate, lossy compression in other regions. In this paper Region of interest part is extracted with the help of Otsu's method of segmentation and compressed with the help of hybrid wavelet transform and then Arithmetic coding thus producing a good quality image. And NROI part is compressed with the help of Haar wavelet transform. Our algorithm provides better PSNR, CR values for medical images.

Keywords- DWT (discrete wavelet transform), DCT(discrete cosine transform)Arithmetic coding, haar wavelet transform, filter, PSNR (Peak signal to noise ratio), Compression Ratio(CR),region of interest(ROI), non region of interest(NROI)

I. INTRODUCTION

(1) Lossless vs. Lossy compression:

In lossless compression, the reconstructed image after compression is numerically identical to the original image on a pixel by-pixel basis. However, only a modest amount of compression is achievable in this technique. In lossy compression on the other hand, the reconstructed image contains degradation relative to the original, because redundant information is discarded during compression. As a result, much higher compression is achievable, and under normal viewing conditions, no visible loss is perceived (visually lossless).

(2) Image compression

Region of interest based Image compression has been one of the hot issues in the field of image compression and coding. However, there is not a fixed model for region of interest automatic detected. In order to reduce storage spaces

and transmission times of infrared target image data, a coding way is proposed for ROI automatic detected of image based on the region growing segmentation algorithm. In order to improve efficiency for transferring image data in real time, a coding-crossed algorithm for ROI automatic detected of infrared target image is studied as same time as it is realized on the frame of Arithmetic coding.

An experimental study is also conducted that is proved the method of detecting automatically and compression algorithm based on region of interest automatic detected is reliable and effective, significant in applications. Non region of interest part is of lesser importance as it is the background part which is not much helpful in diagnosis of the disease. So, using the lossy method of compression for compressing the background part will make the compression easier and will also not affect the issue of diagnosing the disease. Currently, many applications want a representation of the image with minimal storage. Most images contain duplicate data. There are two duplicated parts of data in the image. The first is the existence of a pixel that has the same intensity as its neighboring pixels. These duplicated pixels waste more storage space. The second is that the image contains many repeated sections (regions). These identical sections do not need to be encoded many times to avoid redundancies and, therefore, we need an image compression to minimize the memory requirement in representing a digital image. The general principle used in the process of image compression is to reduce duplication of data within the image so that the memory needed to represent the image is smaller than the original image. The block diagram of the proposed methodology is shown below in figure 1.

The methodology consists of following parts:-

1. Filtering
2. Segmentation of ROI and NROI
3. ROI compressed with the help of hybrid wavelet transform and Arithmetic coding
4. NROI compressed with the help of Haar wavelet transform

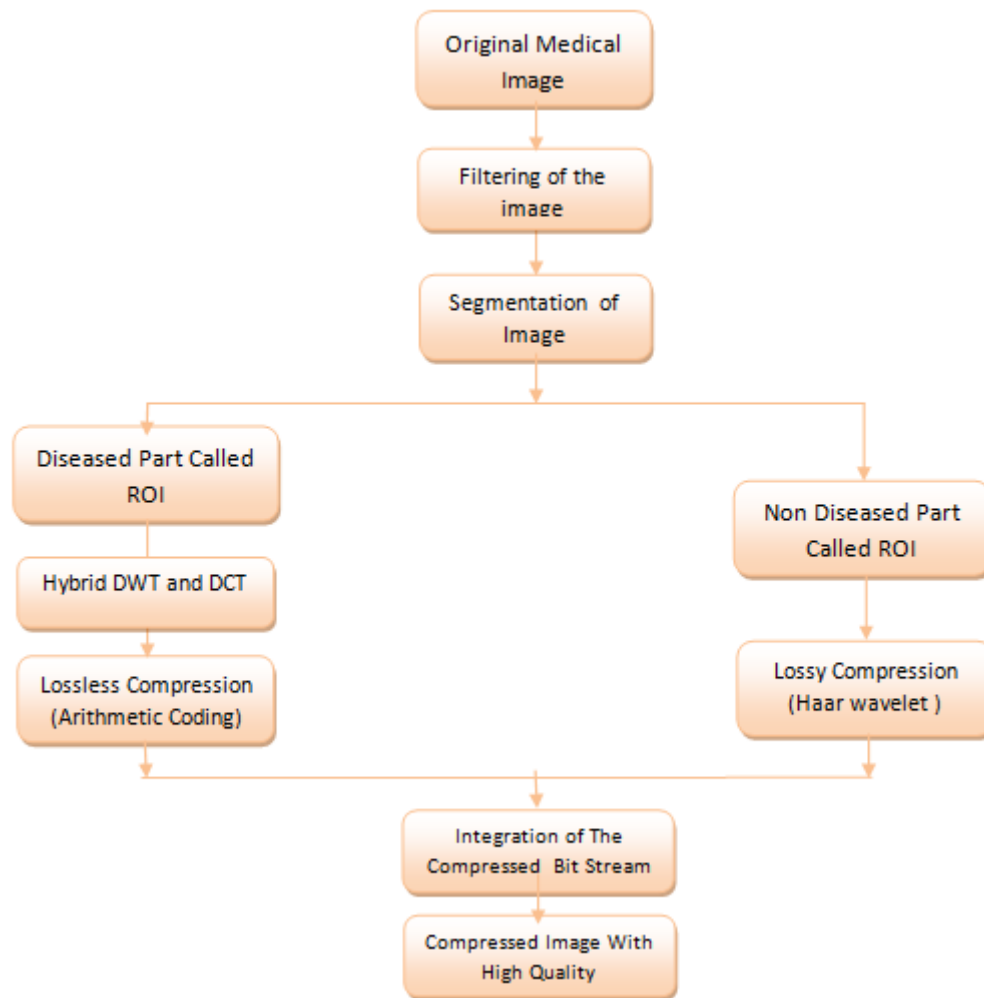

Figure 1: Block Diagram of Methodology

II. METHODOLOGY

1. FILTERING -

In image processing, it is often desirable to be able to perform some kind of noise reduction on an image so that image could be clearly visible. In this methodology median filter is used. The median filter is a non linear digital filtering technique, often used to remove noise. Such noise reduction is a typical preprocessing step to improve the results of later processing. Median filtering is very widely used in digital image processing because, under certain conditions, it preserves edges while removing noise. The main idea of the median filter is to run through the signal entry by entry, replacing each entry with the median of neighboring entries. The pattern of neighbors is called the "window", which slides, entry by entry; over the entire signal. For 2D (higher dimensional) signals such as images, more complex window patterns are possible (such as "box" or "cross" patterns). In this methodology a brain tumor image is considered as shown below:-

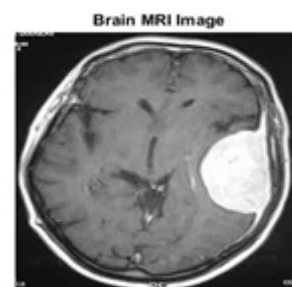

Figure 2: Brain Image with Tumor

2. SEGMENTATION OF ROI AND NROI-

In the proposed methodology Otsu's method is used for segmenting the image into ROI and NROI part. Otsu's method is used to automatically perform clustering-based image thresholding. Clustering based Image thresholding is a simple, yet effective, way of partitioning an image into a foreground and background. This image analysis technique is a type of image segmentation that isolates objects by converting grayscale images into binary images. Image thresholding [6] is most effective in images with high levels of

contrast. The simplest thresholding methods replace each pixel in an image with a black pixel if the image intensity is less than some fixed constant T (that is), or a white pixel if the image intensity is greater than that constant. In this method the ROI part is the tumor part in the brain having the intensity greater than the background part so tumor part is separated from the original brain image and further compressed for transmission.

A. DISCRETE COSINE TRANSFORM (DCT)-

DCT Attempts to decorrelate the image data after decorrelation each transform coefficient can be encoded without dropping off compression efficiency. The DCT and some of its important properties. The DCT for an N×N input sequence can be defined as where x=0, 1, …, n-1, is the list of length n given by:

$$D(i, j) = \frac{1}{\sqrt{2N}} B(i)B(j) \sum_{x=0}^{N-1} \sum_{y=0}^{N-1} M(x, y) \cdot \cos \left[\frac{(2x+1) \pi}{2n} \right] \cos \left[\frac{(2y+1) \pi}{2n} \right]$$

Where,

$$B(u) = \begin{cases} \frac{1}{\sqrt{2\pi}} & \text{if } u = 0 \\ 1 & \text{if } u \neq 0 \end{cases}$$

N is the size of the block that the DCT is applied on. The equation calculates one entry (i, jth) of the transformed image from the pixel values of the original image matrix. M(x,y) is the original data of size x* y.

B. DISCRETE WAVELET TRANSFORM (DWT)-

The DWT represents an image as a sum of wavelet functions, known as wavelets, with different location and scale. The DWT represents the image data into a set of high pass (detail) and low pass (approximate) coefficients. The image is first divided into blocks of 32×32. Each block is then passed through the two filters: the first level decomposition is performed to decompose the input data into an approximation and detail coefficients. After obtaining the transformed matrix, the detail and approximate coefficients are separated as LL,HL, LH, and HH coefficients. All the coefficients are discarded except the LL coefficients that are transformed into the second level. The coefficients are then passed through a constant scaling factor to achieve the desired compression ratio. An illustration is shown in Fig. 2. Here, x[n] is the input signal, d[n] is the high frequency component, and a[n] is the low frequency component. For data reconstruction, the coefficients are rescaled and padded with zeros, and passed through the wavelet filters.

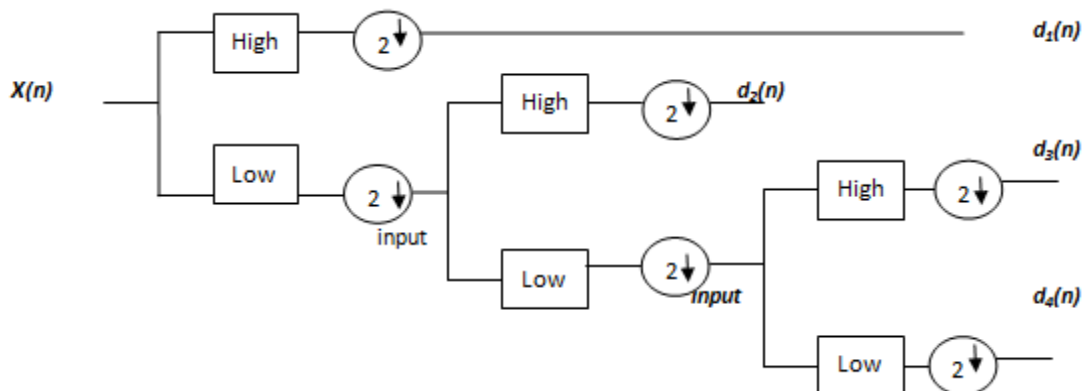
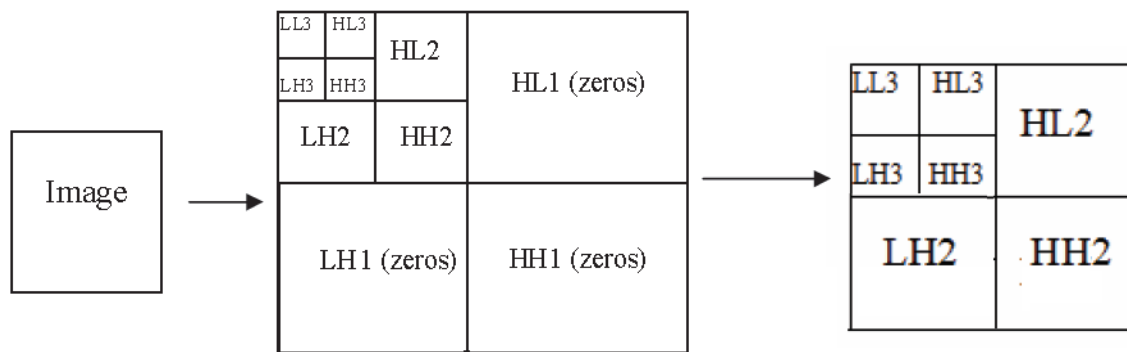

Fig. 2 Block diagram of the 2-level DWT scheme

C. PROPOSED HYBRID DWT- DCT ALGORITHMS:

The main objective of the presented hybrid DWT-DCT algorithm is to exploit the properties of both the DWT and the DCT. Giving consideration of the type of application, original image/frame of size 256×256 (or any resolution, provided divisible by 32) is first divided into blocks of N×N. Each block is then decomposed using the 2-D DWT. (9) Low-frequency coefficients (LL) are passed to the next stage where the high frequency coefficients (HL, LH, and HH) are discarded.



A) First step; Transform image by using three level Discrete Wavelet Transform

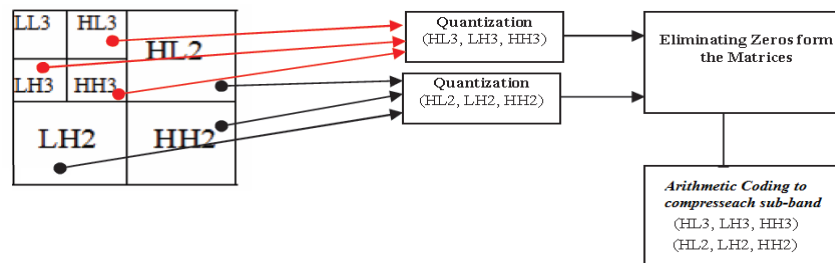

b) Second step; quantization and eliminate zeros from each sub-band, and then compress each sub-band by Arithmetic Coding

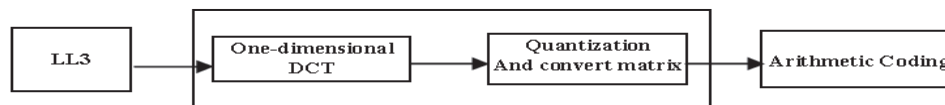

c) Third step; compress LL3 sub-band by using T-Matrix Coding.

Fig 3 - (a, b, c), complete steps for Hybrid DWT- DCT algorithms

The passed LL components are further decomposed using another 2-D DWT. The 8-point DCT is applied to these DWT coefficients. By discarding the majority of the high coefficients, we can achieve a high compression. To achieve further compression, a JPEG-like quantization is performed. In this stage, many of the higher frequency components are rounded to zero. The quantized coefficients are further scaled using scalar quantity known as scaling factor (SF). Each sub-band is to be quantized and the obtained zeros are to be eliminated. On applying 1-D DCT to each sub-band, it is converted to array by using quantization. This process is called T-MATRIX coding. This code is converted to binary data by Arithmetic coding.

III. ARITHMETIC CODING

It is a form of entropy encoding used in lossless data compression. Arithmetic coding is also known as variable length encoding technique. Arithmetic coding encodes the all

message or data into a single number. it is based on probability value. A sequence of input symbols is represented by an interval of real numbers between 0.0 and 1.0. The decision and context are generated by context formation and encoded in the arithmetic encoder. Probability interval is divided into two sub-intervals. If first probability is 1 then a more possible symbol (MPS), it is represented in a gray interval. And second probability is a less possible symbol (LPS). less possible symbol are represented in a white interval. The basic function of the arithmetic encoder is to returning the value of MPS and LPS according to the context and decision from context formation. The intervals of MPS and LPS are dynamically changed. If context and decision are equal to the value of MPS, then code of MPS, otherwise code LPS [8].

The haar wavelet can be applied on Non ROI region. It is performed both lossless and lossy image compression. It relies on averaging and differencing values in an image matrix

to produce a matrix which is sparse or nearly sparse. A sparse matrix is a matrix in which a large portion of its entries are 0. A sparse matrix can be stored in an efficient manner, leading to smaller file sizes. In these notes we will concentrate on grayscale images; however, RGB images can be handled by compressing each of the color layers separately. The basic method is to start with an image A, which can be regarded as an $m \times n$ matrix with values 0 to 255. In Matlab, this would be a matrix with unsigned 8-bit integer values. We then subdivide this image into 8×8 blocks, padding as necessary. It is these 8×8 blocks that we work with. In the proposed methodology the separated NROI part is compressed with the help of the Haar wavelet transform and then reconstructed at the receiver end.

IV. PERFORMANCE PARAMETER

COMPRESSION RATIO:-

Compression Ratio (CR) is defined as number of bit to represent the size of original image to the number of bit to represent the size of compressed image.

$$\text{Compression ratio } R = \frac{\text{no.of bit represent the size of original image}}{\text{no.of bit to represent the size of compressed image}}$$

PEAK SIGNAL TO NOISE RATIO (PSNR) :-

The PSNR is most commonly used as a measure of quality of reconstruction of image.

$$\text{PSNR} = 10 \cdot \text{Log}_{10} \left(\frac{\text{MAX}^2}{\text{MSE}} \right)$$

Here, MAX is the maximum possible pixel value of the image. When the pixels are represented using 8 bits per sample, this is 255.

V. CONCLUSION

At the final stage of the algorithm we have combined the ROI and NROI part and calculated the CR and PSNR value. This paper presented to provide solutions for efficient region based image compression for increasing the compression ratio with less mean square error at minimum processing time based on Hybrid DWT and DCT transform with arithmetic coding,. This hybrid approach was increased the CR and reduce the information loss. Here performance will be analyzed through determining the image quality after decompression, compression ratio, correlation and execution time. Hence we have obtained a satisfactory result and in future we would try to compress colored image.

REFERENCES

- [1] 2011, Salam Benchikh; Michael Corinthios, A Hybrid Image Compression Technique Based On DWT And DCT Transforms Advanced Infocom Technology 2011 (ICAIT 2011), International Conference on IEEE transactions
- [2] 2010, Aree Ali Mohammed; Jamal Ali Hussein Hybrid Transform Coding Scheme For Medical Image Application The 10th IEEE International Symposium On Signal Processing And Information Technology
- [3] 2015, Sharmin Afrose Sabrin Jahan; Anuva Chowdhury "hybrid SVD-DWT-DCT based method for image compression and quality measurement of the compressed image ", IEEE-International Conference on 2012 Third Asian Himalayas International Conference.
- [4] 2012, Smitha Joyce Pinto Jayanand P. Gawande "Performance analysis of medical image compression", IEEE International conference on image compression.
- [5] G. BUELA DIVYA , M. KRUPA SWAROOPA RANI, " Implementation of Image Compression Using Hybrid DWT- DCT Algorithms", International Journal of Modern Trends in Engineering and Research (IJMTER) Volume 02, Issue 07, [July– 2015]
- [6] Gaurav Kumar, Er. Sukhreet Singh Brar, Rajeev Kumar, Ashok Kumar " DWT-DCT Technique and Arithmetic-Huffman Coding based Image Compression", I.J. Engineering and Manufacturing, 2015, 3, 20-33
- [7] Md. Ahasan Kabir, M. A. Masud Khan, Md. Tajul Islam, Md. Liton Hossain, Abu Farzan Mitul Image Compression Using Lifting Based Wavelet Transform Coupled With SPIHT Algorithm ,978-1-4799-0400-6/13/\$31.00 ©2013 IEEE
- [8] M. Venkata Subbarao, N.Sayedu Khasim, Jagadeesh Thati and M. H. H.Sastry,Hybrid Image Compression using DWT and Neural Networks, International Journal of Engineering and Advanced Technology (IJEAT) ISSN: 2249 – 8958, Volume-1, Issue-5, June 2012 490
- [9] J. Papitha, G. Merlin Nancy and D. Nedumaran, Member, IEEE Compression Techniques on MR Image – A Comparative Study,International conference on Communication and Signal Processing, April 3-5, 2013, India,IEEE

- [10] A.M.Raid, W.M.Khedr, M. A. El-dosuky and Wesam Ahmed Jpeg Image Compression Using Discrete Cosine Transform - A Survey ,International Journal of Computer Science & Engineering Survey (IJCSES) Vol.5, April 2014
- [11] Piao Sathish Kumar.S 1, Ellappan.V 2 “MEDICAL IMAGE COMPRESSION BASED ON AUTOMATED ROI SELECTION FOR TELEMEDICINE APPLICATION International Journal Of Engineering And Computer Science ISSN:2319-7242 Volume 3 Issue 1, Jan 2014 Page No. 3638-3642
- [12] Amandeep kaur monika goyal, ROI based Image Compression of Medical Images International Journal of Advance Research in Computer Science and Management Studies2014
- [13] U. S. Mohammed1 and W. M. Abd-Elhafiez2, New Approaches for DCT-Based Image Compression Using Region of Interest Scheme. Applied Mathematics & Information Sciences – An International Journal 2011
- [14] D.VIJENDRA BAB1, Dr.N.R.ALAMELU Wavelet Based Medical Image Compression Using ROI EZW International Journal of Recent Trends in Engineering, Vol 1, No. 3, May 2009
- [15] 2012 Archana Deshlahra “ Analysis of Image Compression Methods Based On Transform and Fractal Coding”
- [16] Radhika Bansal Mrs.Rohini Sharma. Designing an Efficient Image Encryption-Compression System Using A New Haar Wavelet, International Journal of Latest Scientific Research and Technology 1(2), July - 2014, pp. 64-71 ISSN: 2348-9464