

Comparative Analysis of Buck Converter using PID/Fuzzy/Sliding Mode Controller

Nagulapati Kiran¹, E. Appanna²

^{1,2}Department of EEE

^{1,2} Anil Neerukonda Institute of Technology and Sciences, Visakhapatnam, India

Abstract- This paper presents comparative dynamic response of Closed Loop Buck Converter using PID, Fuzzy and Sliding mode control. Output Voltage is compared with a reference signal, which then is processed through a PID controller. The obtained signal is superimposed with a carrier signal and given to switching device used. To further optimize the performance of Buck Converter, Fuzzy controller and sliding mode controller is used. Here Suguno type Fuzzy is used.

Keywords- Buck Converter, PID Controller, Fuzzy Controller, Sliding Mode Controller, Pulse Width Modulation, Suguno

I. INTRODUCTION

Switch-mode power supplies (SMPS) are nonlinear and time-varying systems, and thus the design of a high-performance control is usually a challenging issue. In fact, control should ensure system stability in any operating condition and good static and dynamic performances in terms of rejection of input voltage disturbances and load changes. These characteristics, of course, should be maintained in spite of large input voltage, output current, and even parameter variations.

A classical control approach relies on the state space averaging method, which derives an equivalent model by circuit-averaging all the system variables in a switching period [3–5]. On the assumptions that the switching frequency is much greater than the natural frequency of system variables, low-frequency dynamics is preserved while high-frequency behavior is lost. From the average model, a suitable small signal model is then derived by perturbation and linearization around a precise operating point. Finally, the small-signal model is used to derive all the necessary converter transfer functions to design a linear control system by using classical control techniques. The design procedure is well known, but it is generally not easy to account for the wide variation of system parameters, because of the strong dependence of small-signal model parameters on the converter operating point. Multi-loop control techniques, such as current mode control, have greatly improved power converter dynamic behavior, but the control design remains difficult especially for high-order topologies.

The sliding-mode approach for variable structure systems (VSS) [1],[2] offers an alternative way to implement a control action that exploits the inherent variable structure nature of SMPS. In particular, the converter switches are driven as a function of the instantaneous values of the state variables to force the system trajectory to stay on a suitable selected surface on the phase space. This control technique offers several advantages in SMPS applications [6],[12],[19]: stability even for large supply and load variations, robustness, good dynamic response, and simple implementation. Its capabilities emerge especially in application to high-order converters, yielding improved performances as compared with classical control techniques.

II. BUCK CONVERTER

Figure 1 shows the basic circuit diagram of buck converter. The name “Buck Converter” itself indicates that the input voltage is bucked or attenuated and low voltage appears at the output. A buck converter or step down voltage regulator provides non isolated, switch mode dc-dc conversion with the advantage of simplicity and low cost.

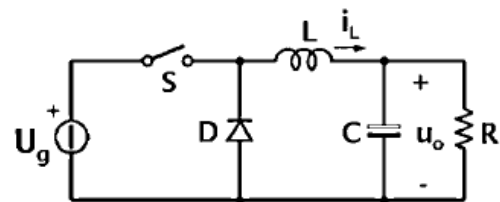

Fig.1 Buck Converter

The buck converter consists of main power switch, a diode, a low-pass filter (L and C) and a load. The basic buck converter operates in ON and OFF states. In ON state i.e. when the switch is closed the current to load is supplied from source voltage through inductor, where inductor gets charged to its peak level. Where as in OFF state i.e. when switch is open the inductor acts as source to the load.

Basic Operation of buck converter is depicted in its equivalent circuit during ON and OFF State.

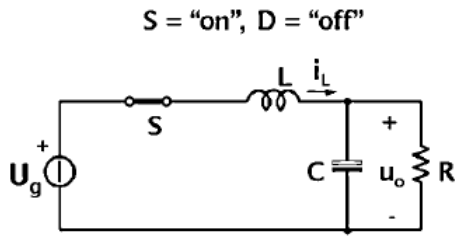

Figure 2. Equivalent Circuit during ON State

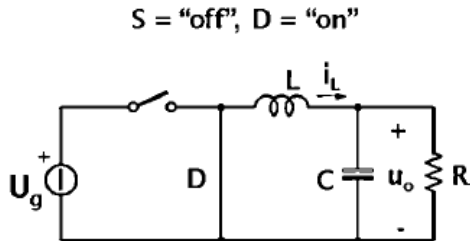

Figure 3. Equivalent Circuit during OFF State

For the buck converter:

$$(Vs - Vo)DT = Vo(1 - D)T \tag{1}$$

Where

V_s : Source Voltage

V_o : Load Voltage

T: Time Period

D: Duty Cycle

Hence the dc voltage transfer function can be defined as the ratio of the output voltage to the input voltage,

$$D = \frac{Vo}{Vs} \tag{2}$$

III. PID CONTROLLER

PID controllers are widely used in industry due to their simplicity and ease of re-tuning on-line. In the past four decades, there are numerous papers dealing with the tuning of PID controllers. A natural question arises: how can the PID settings obtained by different methods are compared? A simple answer is to use step responses of the closed-loop systems and compare the overshoot, rise time and settling time.

An alternative is to use the integral error as a performance index. However, these time domain performance measures do not address directly another important factor of a closed-loop system—robustness. It is a well-known fact that models used for controller tuning or design are often inaccurate, so a PID setting based on optimization assuming an accurate model will generally not be guaranteed to be robust. For a fair comparison of different PID settings, both

time domain performance and frequency domain robustness should be considered.

A PID controller consists of the sum of three control actions, namely, a control action proportional to the control error, a control action proportional to the integral of the control error, and a control action proportional to the first derivative of the control error. Proportional action implements the typical operation of increasing the control variable when the control error is large (with appropriate sign).

The integral action is related to the past values of the control error and allows the reduction to zero of the steady-state error when a step reference signal is applied or a constant load disturbance d occurs.

The derivative action is based on the predicted future values of the control error and has therefore a great potential in improving the control performance as it can anticipate an incorrect trend of the control error and counteract for it.

By "tuning" the three constants in the PID controller algorithm the PID can provide control action designed for specific process requirements. The response of the controller can be described in terms of the responsiveness of the controller to an error, the degree to which the controller overshoots the set point and the degree of system oscillation.

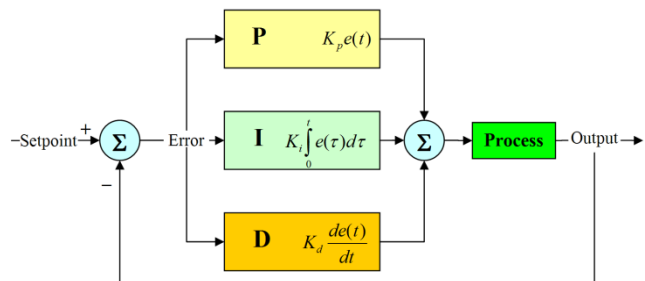

Figure 4. Block Diagram of a PID Controller

In its basic form, the control action can be expressed as

$$U(s) = E(s) \left[Kp + \frac{Ki}{s} + Kds \right] \tag{3}$$

Advantages of PID controllers:

- i. It is easy and simple to implement.
- ii. Easy to understand.
- iii. Reliable for linear systems.

Disadvantages of PID controllers:

- i. It does not reliable and satisfactorily in case of non-linear systems.
- ii. It shows longer rise time when overshoot in output voltage decreases.
- iii. It suffers from dynamic response and produces overshoot affecting the output voltage regulation of converter.
- iv. The dynamic performance is limited because a PI voltage control cannot react to disturbance until the effects have appeared in the converter output.

IV. FUZZY CONTROLLER

A fuzzy controller converts a linguistic control strategy into an automatic control strategy, and fuzzy rules are constructed by expert experience or knowledge database

First, set the error $e(t)$ and the error variation $de(t)$ of the angular velocity to be the input variables of the fuzzy logic controller. The control voltage $u(t)$ is the output variable of the fuzzy logic controller.

The linguistic variables are defined as {mf1, mf2, mf3, mf4, mf5, mf6, mf7}. The fuzzy rules are summarized in Table 3. The type of fuzzy inference engine is Sugano.

e(pu) ce(pu)	mf1	mf2	mf3	mf4	mf5	mf6	mf7
mf1	mf1	mf1	mf2	mf2	mf3	mf3	mf4
mf2	mf1	mf2	mf2	mf3	mf3	mf4	mf5
mf3	mf2	mf2	mf3	mf3	mf4	mf5	mf5
mf4	mf2	mf3	mf3	mf4	mf5	mf5	mf6
mf5	mf3	mf3	mf4	mf5	mf5	mf6	mf6
mf6	mf3	mf4	mf5	mf5	mf6	mf6	mf7
mf7	mf4	mf5	mf5	mf6	mf6	mf7	mf7

Figure 5. Fuzzy Rules

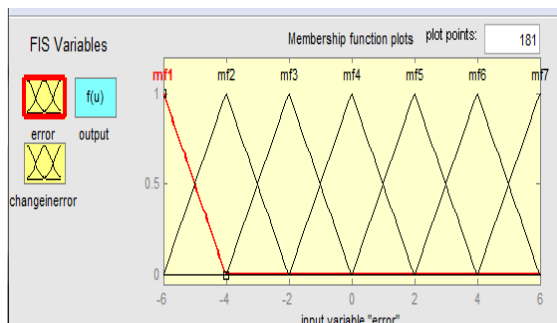

Figure 6. Membership functions for error normalized input

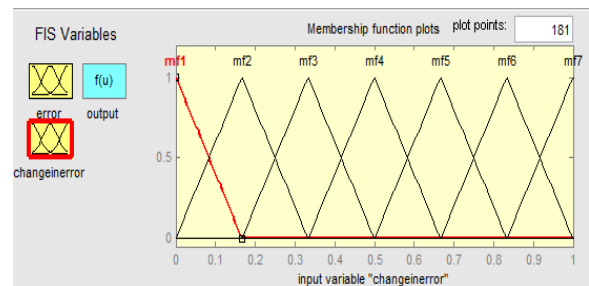

Figure 7. Membership functions for change in error normalized input

Among the various available membership functions, here triangular membership function is used.

IV. SLIDING MODE CONTROLLER

The Sliding Mode (SM) controller was introduced for controlling variable structure systems (VSS). Sliding Mode Controller, a widely used Non-Linear Controller remains vibrant in overcoming the issues of the linear controllers. Sliding mode controller is a variable structure system which operates based on the switching strategy apart from the feedback controllers. They are less sensitive to disturbance and parameter variations due to its binary nature adapting to the modern power switches.

This seems more naturally so since the design of conventional pulse width modulation (PWM) controllers in power electronics is small signal based and they often perform unsatisfactorily under large-signal operating condition. Sliding mode controllers are well known for their robustness and stability. Use of SM controllers can maintain a good regulation for a wider operating range. This has aroused a lot of interests in the use of SM controllers for DC-DC converters. Most of the previously proposed SM controllers for switching power converters are hysteresis modulation (HM) (or delta-modulation) based. Naturally, they inherit the typical disadvantages of having variable switching-frequency operation and being highly control sensitive to noise. Possible solutions are to incorporate constant timer circuits into the hysteretic SM controller to ensure constant switching frequency operation or to use adaptive hysteresis band that varies with parameter changes to control and fixate the switching frequency. However, these solutions require additional components and are unattractive for low cost voltage conversion applications.

An alternative solution to this is to change the modulation method of the SM controllers from HM to pulse-width modulation (PWM). The idea is based on the assumption that at a high switching frequency, the control action of a sliding mode controller is equivalent to the duty

cycle control action of a PWM controller. Hence, the migration of a sliding mode controller from being HM based to PWM based is made possible.

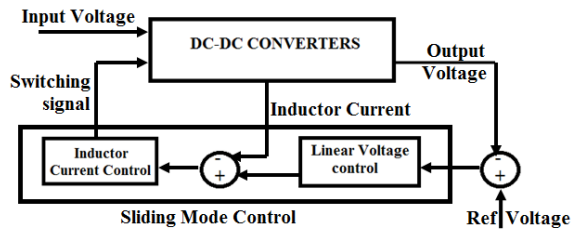

Figure. 8 Block Diagram of Sliding Mode Control

The basic principle behind the SMC controlled system is to drive the converter to the steady surface called the sliding surface and maintain the stability of the system thus giving the regulated output voltage for any variations in the load or switching frequency.

Sliding Mode control principle is graphically represented in figure-4.

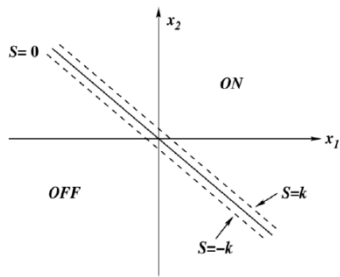

Figure 9. Sliding mode on x_1-x_2 phase plane

IV. SIMULATION RESULTS

The Closed Loop performance of Buck Converter using PID Controller, Fuzzy Controller and Sliding Mode Controller is simulated with MATLAB/SIMULINK. Dynamic Response of output voltage and output current of Buck Converter using PID Controller, Fuzzy Controller and Sliding Mode Controller is obtained.

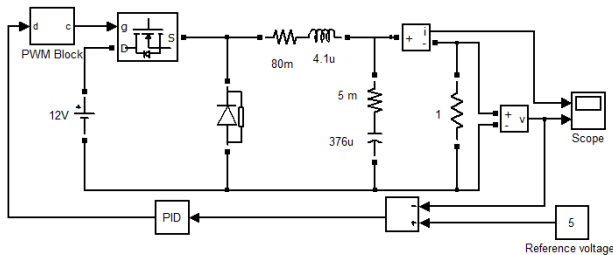

Figure 10. Simulink Model of Buck Converter using PI Controller

Figure 10 shows Simulink model of Closed Loop Buck Converter using PI Controller

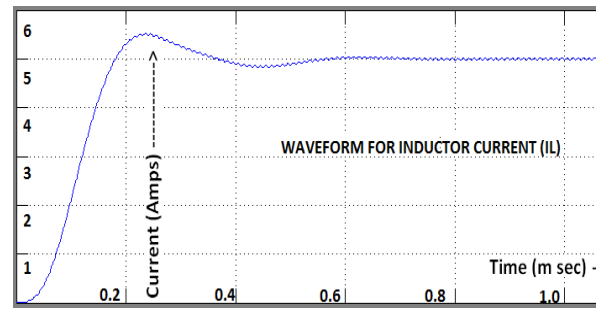

Figure 11. Output Current waveform of Buck Waveform using PID Controller

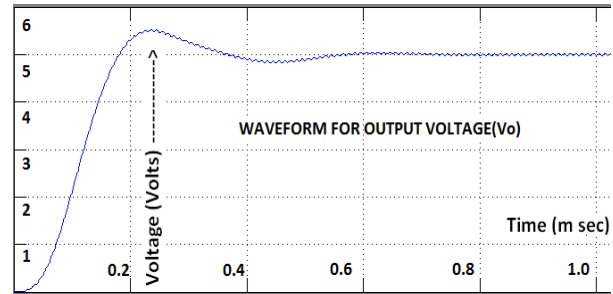

Figure. 12 Output Voltage waveform of Buck Waveform using PID Controller

Figures 11 and 12 shows the obtained waveforms for output current and output voltage respectively for Closed loop Buck Converter using PI Controller.

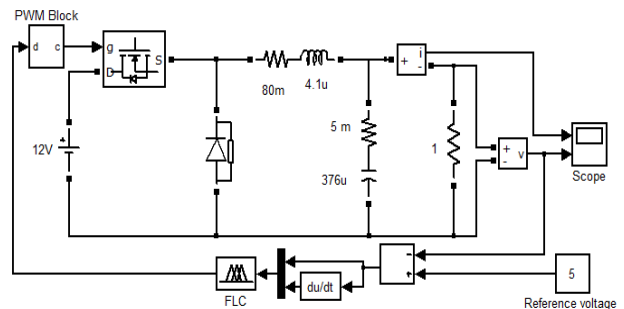

Figure. 13 Simulink Model of Buck Converter using Fuzzy Controller

Figure 13 shows Simulink model of Closed loop Buck Converter using Fuzzy Controller.

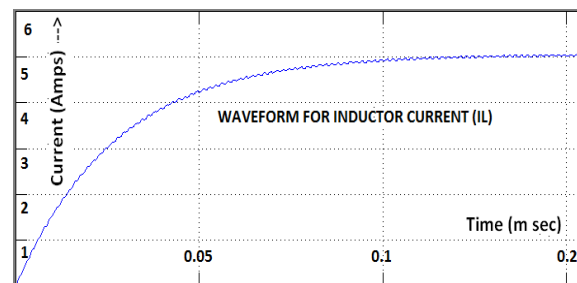

Figure. 14 Output Current waveform of Buck Waveform using Fuzzy Controller

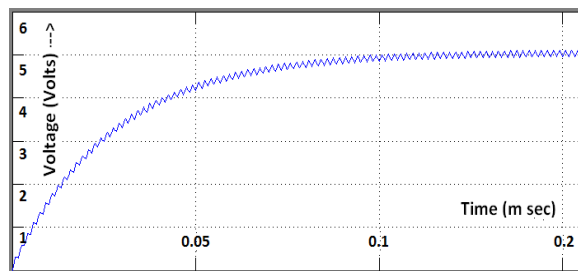

Figure. 15 Output Voltage waveform of Buck Converter using Fuzzy Controller

Figures 14 and 15 shows the obtained waveforms for output current and output voltage respectively for Closed loop Buck Converter using Fuzzy Controller.

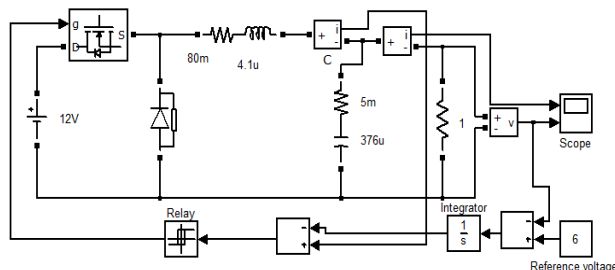

Figure. 16 Simulink Model of Buck Converter using Sliding Mode Controller

Figure 16 shows Simulink model of Closed Loop Buck Converter using Sliding Mode Controller

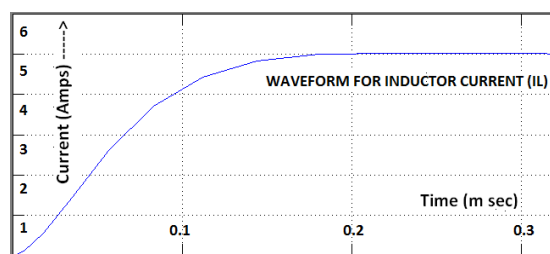

Figure. 17 Output Current waveform of Buck Converter using Sliding Mode Controller

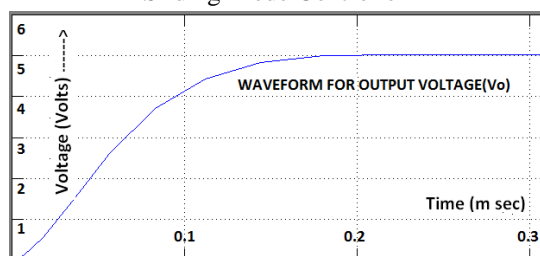

Figure. 18 Output Voltage waveform of Buck Converter using Sliding Mode Controller

Figures 17 and 18 shows the obtained waveforms for output current and output voltage respectively for Closed loop Buck Converter using Sliding Mode Controller.

V. CONCLUSION

The Closed Loop performance of Buck Converter using PID Controller, Fuzzy Controller and Sliding Mode Controller is simulated with MATLAB/SIMULINK. Dynamic Response of output voltage and output current of Buck Converter using PID Controller, Fuzzy Controller and Sliding Mode Controller is compared.

REFERENCES

- [1] V. I. Utkin, Sliding Modes and Their Application in Variable Structure Systems, MIR Publishers, Moscow, 1978.
- [2] U. Itkis, Control Systems of Variable Structure, John Wiley & Sons, New York, 1976.
- [3] R. D. Middlebrook and S. Cuk, Advances in Switched-Mode Power Conversion, Vol. I and II, TESLACO, Pasadena, CA, 1983, 73–89.
- [4] R. Redl and N. Sokal, Current-mode control, five different types, used with the three basic classes of power converters: small-signal AC and large-signal DC characterization, stability requirements, and implementation of practical circuits, in IEEE-PESC, 1985, 771–785.
- [5] J. G. Kassakian, M. F. Schlecht, and G. C. Verghese, Principles of Power Electronics, Addison-Wesley, Reading, MA, 1991.
- [6] R. Venkataramanan, A. Sabanovic, and S. Cúk, Sliding-mode control of DC-to-DC converters, in IECON Conf. Proc., 1985, 251–258.
- [7] B. Nicolas, M. Fadel, and Y. Chéron, Robust control of switched power converters via sliding mode, ETEP, 6(6), 413–418, 1996.
- [8] B. Nicolas, M. Fadel, and Y. Chéron, Sliding mode control of DC-to-DC converters with input filter based on Lyapunov-function approach, in EPE Conf. Proc., 1995, 1.338–1.343.
- [9] L. Malesani, L. Rossetto, G. Spiazzi, and P. Tenti, Performance optimization of Cúk converters by sliding-mode control, IEEE Trans. Power Electron., 10(3), 302–309, 1995.
- [10] P. Mattavelli, L. Rossetto, G. Spiazzi, and P. Tenti, General-purpose sliding-mode controller for DC/DC

- converter applications, in Proc. of IEEE Power Electronics Specialists Conf. (PESC), Seattle, June 1993, 609–615.
- [11] P. Mattavelli, L. Rossetto, G. Spiazzi, and P. Tenti, Sliding mode control of SEPIC converters, in Proc. of European Space Power Conf. (ESPC), Graz, August 1993, 173–178.
- [12] J. Fernando Silva and Sonia S. Paulo, Fixed frequency sliding mode modulator for current mode PWM inverters, in Power Electronics Specialists Conf. Proc. (PESC), 1993, 623–629.
- [13] P. Mattavelli, L. Rossetto, and G. Spiazzi, Small-signal analysis of DC-DC converters with sliding mode control, *IEEE Trans. Power Electron.*, 12(1), 79–86, 1997.
- [14] N. Sabanovic, A. Sabanovic, and K. Ohnishi, Sliding mode control of three-phase switching converters, in Proc. of Int. Conf. on Industrial Electronics, Control and Instrumentation (IECON), San Diego, 1992, 319–325.
- [15] N. Sabanovic-Behlilovic, A. Sabanovic, and T. Ninomiya, PWM in three-phase switching converters sliding mode solution, in Power Electronics Specialists Conference, PESC '94 Record, 25th Annual IEEE, Vol. 1, 1994, 560–565.
- [16] L. Rossetto, G. Spiazzi, B. Fabiano, and C. Licitra, Fast-response high-quality rectifier with sliding mode control, *IEEE Trans. Power Electron.*, 9(2), 146–152, 1994.
- [17] L. Malesani, L. Rossetto, G. Spiazzi, and A. Zuccato, An AC power supply with sliding-mode control, *IEEE Ind. Appl. Mag.*, 2(5), 32–38, 1996.
- [18] H. Pinheiro, A. S. Martins, and J. R. Pinheiro, A sliding mode controller in single phase voltage source inverters, in IEEE IECON '94, 1994, 394–398.
- [19] H. Sira-Ramirez and M. Rios-Bolivar, Sliding mode control of DC-to-DC power converters via extended linearization circuits and systems I: fundamental theory and applications, *IEEE Transactions on Circuits and Systems* 41(10), 652–661, 1994.
- [20] Muhammad Saad Rahman, “Buck Converter Design Issues,” Master thesis performed in division of Electronic Devices, Linkoping Institute of Technology, Linkoping, 2007. [21] D. Maksimovic, R. Zane, and R. Erickson, “Impact of digital control in power electronics,” in Proc. IEEE Int. Symp. Power Semicond. Devices ICs, 2004, pp. 13–22.
- [21] V. Utkin, J. Guldner, and J.X. Shi, Sliding Mode Control in Electromechanical Systems. London, U.K.: Taylor and Francis, 1999.
- [22] V. Utkin, Sliding Modes in Control Optimization. Berlin: Springer-Verlag, 1992.
- [23] C. Edwards and S.K. Spurgeron, Sliding Mode Control: Theory and Applications. London, U.K.: Taylor and Francis, 1998.
- [24] M. Castilla, L.C. de Vicuna, M. Lopez, O. Lopez, and J. Matas, “On the design of sliding mode control schemes for quantum resonant converters,” *IEEE Transactions on Power Electronics*, vol. 15 no. 15, pp. 960–973, Nov. 2000.
- [25] S.K. Mazumder, A.H. Nayfeh, A. Borojevic, P. Gaya, and O. L’opez, “Robust control of parallel DC–DC buck converters by combining integral-variable-structure and multiple-sliding-surface control schemes,” *IEEE Transactions on Power Electronics*, vol. 17, no. 3, pp. 428–437, May 2002.
- [26] M. L’opez, L.G. De-Vicu’na, M. Castilla, P. Gaya, and O. L’opez, “Current distribution control design for paralleled DC/DC converters using sliding-mode control,” *IEEE Transactions on Industrial Electronics*, vol. 45, no. 10, pp. 1091–1100, Apr. 2004.
- [27] S.K. Mazumder and S.L. Kamisetty, “Design and experimental validation of a multiphase VRM controller”, in Proceedings, IEE Electric Power Applications, vol. 152, no. 5, pp. 1076–1084, Sep. 2005.