

# Password Based Lock for Bike Security with Ignition Key Control System

K. Dinesh Kumar<sup>1</sup>, B. Sasidharan<sup>2</sup>, B. Sruthi Keerthana<sup>3</sup>, N. Tamil Selvan<sup>4</sup>, N. L. Sivasundharam<sup>5</sup>

<sup>1, 2, 3, 4, 5</sup> Department of CSE  
<sup>1, 2, 3, 4, 5</sup> K.S.R college of Engineering, Tiruchengode.

**Abstract-** Many times we hear the cases of bikes getting stolen from parking area or sometimes we forgot to remove the keys from bike by mistake. In these cases it is really difficult to get the bike back. This project is designed to solve this purpose. Main concept behind this project is of a bike security system using a password entered through keypad. This system turns on the Buzzer when wrong password is entered for 3 times. User can change this password anytime he/she wish using a keypad. It uses Microcontroller: This is the CPU (central processing unit) of our project. This project has GSM technology and Vehicle anti-theft system with vehicle ignition controlling technique. Whenever bike owner removes key from the ignition lock at that system is turned on. We have provided vibration sensor with this project, which is similar to piezoelectric sensor. When vibrations are detected, SMS is sent to the owner of the bike. When car owner sends back SMS to project then the engine is stopped. We have provided a Relay and a DC motor to show the demo of vehicle engine controlling system.

**Keywords-** GSM, Wireless Technology, Short Messaging Service, Mobile Phone.

## I. INTRODUCTION

In this system we place the chip in ignition system of the bike. Main concept behind this project is of a bike security system using a password entered through keypad. This project has GSM technology and Vehicle anti-theft system with vehicle ignition controlling technique.

## II. EXISTING SYSTEM

The removal of a vehicle that the owner or operator has left unattended with the keys visibly present, sometimes idling. Alternatively, some bikes offered for sale are stolen during a 'test drive'. A 'test drive' may also provide a potential thief with insight into where the vehicle keys are stored, so that the thief may return later to steal the vehicle.. Illegal acquisition of a vehicle from a seller through fraudulent transfer of funds that the seller will ultimately not receive (such as by identity theft or the use of a counterfeit cashier's check), or through the use of a loan obtained under false pretenses. Refers to the taking of a vehicle by force or threat

of force from its owner or operator. In most places, this is the most serious form of theft, since assault also occurs. In some carjacking's, the operators and passengers are forced from the vehicle while the thief drives it away him/herself, while in other incidents, the operator and/or passenger(s) are forced to remain in the vehicle as hostages. Some less common carjacking's result in the operator being forced to drive the assailant in accordance with the assailant's demands.

## III. PROPOSED SYSTEM

This proposed system is designed to solve this purpose. Main concept behind this project is of a bike security system using a password entered through keypad. This project has GSM technology and Vehicle anti-theft system with vehicle ignition controlling technique. We have provided vibration sensor with this project, which is similar to piezoelectric sensor. When vibrations are detected, SMS is sent to the owner of the vehicle. When vehicle owner sends back sms to project then the engine is stopped. Thus this proposed system is used to prevent the bike theft and identified the location of the vehicle.

## IV. CIRCUIT DIAGRAM

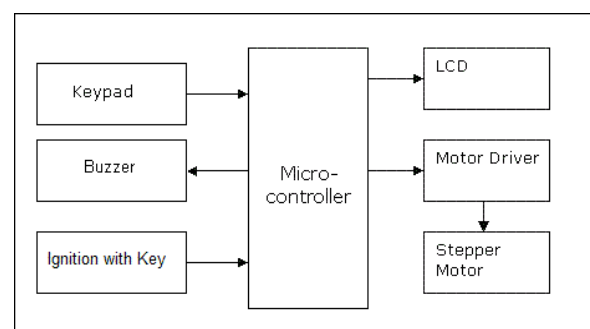

## V. HARDWARE DESCRIPTION

### 5.1 MICROCONTROLLER

Microcontroller PIC16F877A is one of the PIC Micro Family microcontroller which is popular at this moment, start from beginner until all professionals. Because it is very easy using PIC16F877A and use FLASH

Many vehicles stolen via fraud are resold quickly thereafter. The superiority this RISC Microcontroller compared to with other microcontroller 8-bit especially at a compression. PIC16F877A have 40 pin by 33 path of I/O. PIC16F877A perfectly fits many uses, from automotive industries and controlling home appliances to industrial instruments, remote sensors, electrical door locks and safety devices. It is also ideal for smart cards as well as for battery supplied devices because of its low consumption. EEPROM memory makes it easier to apply microcontrollers to devices where permanent storage of various parameters is needed (codes for transmitters, motor speed, receiver frequencies, etc.). Low cost, low consumption, easy handling and flexibility make PIC16F877A applicable even in areas where microcontrollers had not previously been considered (example: timer functions, interface replacement in larger systems, coprocessor applications, etc.). In System Programmability of this chip (along with using only two pins in data transfer) makes possible the flexibility of a product, after assembling and testing have been completed.

**5.1.1 ARCHITRCTURE OF 16F877A**

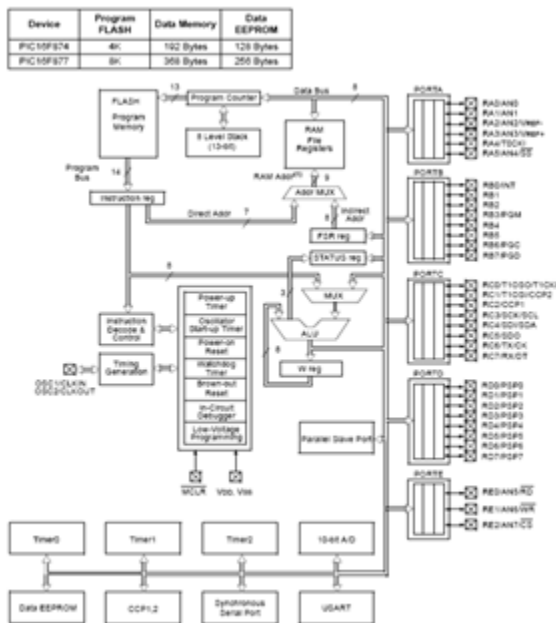

**5.1.2 MEMORY ORGANIZATION**

There are two memory blocks in Memory. Program memory and Data memory. Each block has its own bus, so that access to each block can occur during the same oscillator cycle. The data memory can further be broken down into General Purpose RAM and the Special Function Registers (SFRs). The operations of the SFRs that control the “core” are described here. The SFRs used to control the peripheral

modules are described in the section discussing each individual peripheral module.

**5.1.3 CIRCUIT DIAGRAM**

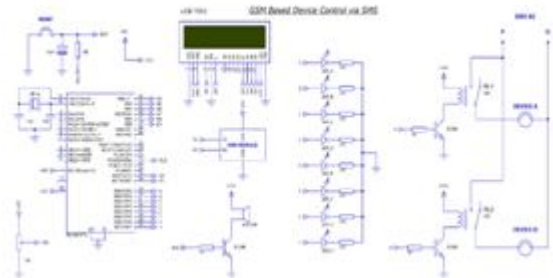

**5.2 POWER SUPPLY**

The ac voltage, typically 220V, is connected to a transformer, which steps that ac voltage down to the level of the desired dc output. A diode rectifier then provides a full-wave rectified voltage that is initially filtered by a simple capacitor filter to produce a dc voltage. This resulting dc voltage usually has some ripple or ac voltage variation.

**5.3 GSM MODEM**

A GSM modem is a wireless modem that works with a GSM wireless network. A wireless modem behaves like a dial-up modem. The main difference between them is that a dial-up modem sends and receives data through a fixed telephone line while a wireless modem sends and receives data through radio waves. A GSM modem can be an external device or a PC Card / PCMCIA Card. Typically, an external GSM modem is connected to a computer through a serial cable or a USB cable. A GSM modem in the form of a like a GSM mobile phone, a GSM modem requires a SIM card from a wireless carrier in order to operate. As mentioned in earlier sections of this SMS tutorial, computers use AT commands to control modems. Both GSM modems and dial-up modems support a common set of standard AT commands. You can use a GSM modem just like a dial-up modem. In addition to the standard AT commands, GSM modems support an extended set of AT commands. These extended AT commands are defined in the GSM standards. With the extended AT commands, you can do things like

- Reading, writing and deleting SMS messages.
- Sending SMS messages.
- Monitoring the signal strength.
- Monitoring the charging status and charge level of the battery.
- Reading, writing and searching phone book entries.

The number of SMS messages that can be processed by a GSM modem per minute is very low -- only about six to ten SMS messages per minute.

## 5.4 SMS

SMS stands for Short Message Service. It is a technology that enables the sending and receiving of messages between mobile phones. SMS first appeared in Europe in 1992. It was included in the GSM (Global System for Mobile Communications) standards right at the beginning. Later it was ported to wireless technologies like CDMA and TDMA. The GSM and SMS standards were originally developed by ETSI. ETSI Partnership Project) is responsible for the development and maintenance of the GSM and SMS standards.

As suggested by the name "Short Message Service", the data that can be held by an SMS message is very limited. One SMS message can contain at most 140 bytes (1120 bits) of data, so one SMS message can contain up to:

- 160 characters if 7-bit character encoding is used. (7-bit character encoding is suitable for encoding Latin characters like English alphabets.)
- 70 characters if 16-bit Unicode UCS2 character encoding is used. (SMS text messages containing non-Latin characters like Chinese characters should use 16-bit character encoding.)

SMS text messaging supports languages internationally. It works fine with all languages supported by Unicode, including Arabic, Chinese, Japanese and Korean. Besides text, SMS messages can also carry binary data. It is possible to send ringtones, pictures, operator logos, wallpapers, animations, business cards (e.g. VCards) and WAP configurations to a mobile phone with SMS messages. One major advantage of SMS is that it is supported by 100% GSM mobile phones. Almost all subscription plans provided by wireless carriers include inexpensive SMS messaging service. Unlike SMS, mobile technologies such as WAP and mobile Java are not supported on many old mobile phone models.

### 5.4.1 Concatenated SMS Messages / Long SMS Messages

One drawback of the SMS technology is that one SMS message can only carry a very limited amount of data. To overcome this drawback, an extension called concatenated SMS (also known as long SMS) was developed. A concatenated SMS text message can contain more than 160 English characters. Concatenated SMS works like this: The sender's mobile phone breaks down a long message into

smaller parts and sends each of them as a single SMS message. When these SMS messages reach the destination, the recipient mobile phone will combine them back to one long message.

### 5.4.2 EMS (Enhanced Messaging Service)

Besides the data size limitation, SMS has another major drawback -- an SMS message cannot include rich-media content such as pictures, is the abbreviation for European Telecommunications Standards Institute. Now the 3GPP(Third Generation animations and melodies. EMS (Enhanced Messaging Service) was developed in response to this. It is an application-level extension of SMS. An EMS message can include pictures, animations and melodies. Also, the formatting of the text inside an EMS message is changeable. For example, the message sender can specify whether the text in an EMS message should be displayed in bold or italic, with a large font or a small font.

The drawback of EMS is that it is less widely supported than SMS on wireless devices. Also, many EMS-enabled wireless devices only support a subset of the features defined in the EMS specification. A certain EMS feature may be supported on one wireless device but not on the other.

## VI. SOFTWARE DESCRIPTION

Software in the embedded system is implanted with either assembly language or any high level language. Now-a-days C and C++ has been the choice but language for the embedded software for the following reasons.

- C and C++ are machine independent language, so the programmer can concentrate only on the algorithms.
- C has the ability for direct hardware control and it can be interfaced to run any mechanical machine.

Any source code written in C and C++ or assembly must be converted into an executable image that can be loaded onto an EEPROM chip. The process of converting the source code representation of embedded software into an executable image involves three distinct steps and the system or computer on which these processes are executed is called host computer. There are some differences between conventional programming and embedded programming. Even if the processor architecture is the same, the I/O interfaces or sensors or activators may differ. Second, there is a difference in the development and debugging of applications. The Embedded system software comprise of building program that will run on the host. These tools are called Native tools. Some of them are

### 6.1.1 Cross-Compilers

The compiler that runs on the host system and produces the binary instructions that will be understood by the target microprocessor is called Cross-Compiler.

### 6.1.2 Cross-Assembler

A Cross assembler is the assembler that produce binary instruction.

### 6.1.3 Linker/Locator

Linker/Locator links all the object files produced by the cross compiler and assembler. The loader finds memory into load the program from the disk into the memory and may then do various other processing before starting the program.

## VII. SOFTWARE SPECIFICATION

### 7.1 FRONT END

#### 7.1.1 Zigbee Protocol Uses

ZigBee builds upon the physical layer and medium access control defined in for low-rate WPANs. The specification goes on to complete the standard by adding four main components: network layer, application layer, ZigBee device objects (ZDOs) and manufacturer-defined application objects which allow for customization and favor total integration. Besides adding two high-level network layers to the underlying structure, the most significant improvement is the introduction of ZDOs. These are responsible for a number of tasks, which include keeping of device roles, management of requests to join a network, device discovery and security. ZigBee is not intended to support power line networking but to interface with it at least for smart metering and smart appliance purposes. ZigBee protocols are intended for embedded applications requiring low data rates and low power consumption. The resulting network will use very small amounts of power — individual devices must have a battery life of at least two years to pass ZigBee certification.

### 7.2 BACK END

#### 7.2.1 Embedded C

Embedded systems have become increasing digital with a non-digital peripheral (analog power) and therefore both Hardware and software coding signs are relevant. Most embedded control product must special requirement, cost effectiveness, low power, small-footprint and a high level of

system integration. Typically, most embedded control systems are control system, that are designed around an MCU, which integrates on-chip program memory, data memory (RAM) and various peripheral functions, such as timer and serial communication. In addition, these systems usually require analog/interface devices, serial EEPROM display driver's keypads or small displays.

## VIII. PCB DESIGN

### 8.1 INTRODUCTION

Printed circuit boards, or PCBs, form the core of electronic equipment domestic and industrial. Some of the areas where PCBs are intensively used are computers, process control, telecommunications and instrumentation.

### 8.2 MANUFACTURING

The manufacturing process consists of two methods; print and etch, and print, plate and etch. The single sided PCBs are usually made using the print and etch method. The double sided plate through – hole (PTH) boards are made by the print plate and etch method. The production of multi-layer boards uses both the methods. The inner layers are printed and etch while the outer layers are produced by print, plate and etch after pressing the inner layers.

### 8.3 SOFTWARE

The software used in our project to obtain the schematic layout is MICROSIM.

### 8.4 PENALIZATION

Here the schematic transformed in to the working positive/negative films. The circuit is repeated conveniently to accommodate economically as many circuits as possible in a panel, which can be operated in every sequel of subsequent steps in the PCB process. This is called penalization. For the PTH boards, the next operation is drilling.

## IX. RESULT & CONCLUSION

This project may helpful to the people who are earning a very less salaries and the people who are richest, earning high salaries by keeping a powerful security on their own vehicles, they can move anywhere they want by parking the vehicle at unknown place. This may useful to each and every person in day to day life and they will never afraid of the vehicle thefters. By this project people come to existence that our country is developing and they move forward the leg

with full of dareness in their minds. In future we want to develop the same project but by adding a default user identifier and in future we can make this project very bright, by using a snapshot video camera whenever a thief ready for stealing the vehicle, as it records the total scenario happening and also it sends the message to the owner of the vehicle by using the GSM and GPRS technologies.



## REFERENCES

- [1] Design and Development of GPS Based vehicle tracking system for commercial intercity buses. Fleisher , Paul Benjamine; Nelson , Atso Yao; SowahRobert Adjetej; Bremang, Appah Department of computer engineering , university of ghana.. 2012 IEEE 4th International Conference on Adaptive Science &Technology (ICAST)
- [2] Active Target Tracking and Cooperative Localization for Teams of Aerial Vehicles Fabio Morbidi, Member, IEEE, and Gian Luca Mariottini, Member, IEEE,, IEEE TRANSACTIONS ON CONTROL SYSTEMS TECHNOLOGY, VOL. 21, NO. 5, SEPTEMBER 2013.
- [3] Probabilistic Long-Term Vehicle Motion Prediction and Tracking in Large Environments ,Mao Shan, Member, IEEE, Stewart Worrall, Member, IEEE, and Eduardo Nebot, Senior Member, IEEE, IEEE TRANSACTIONS ON INTELLIGENT TRANSPORTATION SYSTEMS, VOL. 14, NO. 2, JUNE 2013
- [4] Integrated Lane and Vehicle Detection, Localization, and Tracking: A Synergistic Approach SayananSivaraman, Student Member, IEEE, and Mohan Manubhai Trivedi, Fellow, IEEE,, IEEE TRANSACTIONS ON INTELLIGENT TRANSPORTATION SYSTEMS, VOL. 14, NO. 2, JUNE 2013
- [5] Front Sensor and GPS-Based Lateral, Control of Automated Vehicles, Jing Yang, Student Member, IEEE, Edwin Hou, Senior Member, IEEE, and MengChu Zhou, Fellow, IEEE TRANSACTIONS ON INTELLIGENT TRANSPORTATION SYSTEMS, VOL. 14, NO. 1, MARCH 2013.
- [6] R. K. Singh, “Crime in India 2011 -Statistics”, for National Crime Records Bureau 2011.
- [7] Karl Koscher, Alexei Czeskis, FranziskaRoesner, Shwetak Patel, Tadayoshi Kohno, Stephen Checkoway, Damon McCoy, Brian Kantor, Danny Anderson, HovavShacham, and Stefan Savage “Experimental Security Analysis of a Modern Automobile”, IEEE Symposium on Security and Privacy, 2010.
- [8] Pierre Kleberger, Tomas Olovsson, and ErlandJonsson, “Security Aspects of the In-Vehicle Network in the Connected Car”, IEEE Intelligent Vehicles Symposium (IV) Baden-Baden, Germany, June 5-9, 2011.
- [9] Vishal P. Patil, Dr. K.B. Khanchandani, “Design and Implementation of Automotive Security System using ARM Processor,” International Journal of Engineering Science and Innovative Technology (IJESIT) Volume 2, Issue 1, January 2013.
- [10] Montaser N. Ramadan, Mohammad A. Al-Khedher, “Intelligent Anti-Theft and Tracking System for Automobiles” International Journal of Machine Learning and Computing, Vol. 2, No. 1, February 2012
- [11] Jiwa Abdullah, “The Design of Mobile Control Car Security System”, IACSIT International Journal of Engineering and Technology, Vol.3, No.3, June 2011.
- [12] T. K. Kishore, T. S. Vardhan, and N. L. Narayana, “Vehicle Tracking Using a Reliable Embedded Data Acquisition Sysytem with GPS and GSM”, International Journal of Computer Science and Network Security, Vol. 10, No. 2, pp. 286-291, 2010.
- [13] University of Nebraska “Untangling the GPS Data String”, Institute of Agriculture and Natural Resources Cooperative Extension EC 01-157. [10] National Marine Electronics Association, “NMEA 0183 Standard for Interfacing Marine Electronic Devices,” Version 3.01, January 1, 2002.