

Autonomous Battery Fed LED Street Lighting System Using Boost Converter

Ramesh R¹, Ramji M², Rangasamy G³, Rohith R⁴

^{1,2,3,4} Department of EEE

^{1,2,3,4} Saranathan College of Engineering, Trichy, Tamilnadu, India

Abstract- In this paper the design and the development of a battery powered LED street lighting system which can be used in areas where, utility power supply is not available is explained. Boost converter, a DC – DC converter is used to step up the battery terminal voltage to meet the load voltage. PWM signals to turn the switch ON and OFF is generated by Arduino microcontroller. The voltage across the load is maintained constant by varying duty cycle through microcontroller. Autonomous turn ON and OFF of the system is carried out through LDR based on the ambient light.

Keywords- LED, PWM, Arduino, DC-DC converter.

I. INTRODUCTION

In India, providing public lighting is one important function that urban league bodies (ULB), commonly known as municipalities, fulfill. Street lighting provides an important function; keeping pedestrians, drivers, and other roadway users safe, while promoting use of public spaces. Studies have shown that proper street lighting can substantially reduce fatalities and crashes with pedestrians and lighted intersections and highways have fewer crashes than their unlit counterparts. However, public lighting is costly for local governments. Street lights have high hours-of-use (they are ON for over 4,000 hours per year) and thus are large consumers of energy. The Clinton Climate Initiative indicated that municipal street lighting can represent from 5% to over 60% of a municipal government's electric bill, depending on the municipality's size, the services it offers, and the efficiency of its public lighting. Despite the considerable expense and electricity use of public lighting, underserved areas exist throughout India as street lighting in Indian towns and cities is sometimes ill-maintained. In a 2010 report, the United States Agency for International Development (USAID) and the Bureau of Energy Efficiency in India (BEE) published guidelines to increase awareness of the BIS standards. They provided basic information on design, procurement, operations and maintenance, and measurement and verification options for street lighting projects in India and they are:

- Selection of inefficient luminaires
- Stocking problem (due to lack of storage space and poor

storage conditions)

- Poor design and installation
- Poor power quality
- Poor operation and maintenance practices
- They determined that tremendous potential exists to improve lighting quality, by improved operations and maintenance practices.

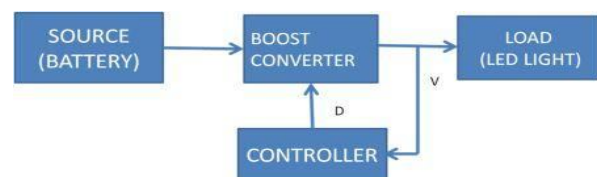

Fig 1.1 Overall Operation

The block diagram shown in fig 1.1 shows the overall operation of Battery fed LED lighting system using Boost converter. Here the battery acts as the source of the system and LED street light acts as the load. BOOST converter, a DC-DC converter steps up the battery terminal voltage to required load voltage. Thus it acts as a driver circuit to the load. The feedback system is to maintain the voltage constant at the load. The output voltage across the BOOST converter is fed to the controller and by varying the duty cycle, the voltage across the converter is kept constant

II. AUTONOMOUS OPERATION

The block diagram shown in fig 1.2 shows the autonomous operation of the battery fed LED lighting system using Boost converter. The system makes use of LDR. A Light Dependent Resistor which makes the LED lighting system to switch ON automatically based on the resistor value ambient light. A predetermined battery terminal voltage is set in the controller. When the battery attains that predetermined voltage the controller makes the LED light to turn OFF.

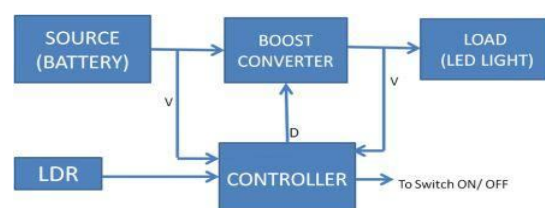

Fig 2.1 Autonomous Operation Block Diagram

III. CHARGE MANAGEMENT OF LEAD ACID BATTERIES

Over-discharge leads to sulfation and the battery is ruined. The reaction becomes irreversible when the size of the Lead-sulphate formations become too large. Overcharging causes other undesirable reactions to occur Electrolysis of water and generation of hydrogen gas. Electrolysis of other compounds in electrodes and electrolyte, which can generate poisonous gases. Bulging and deformation of cases of sealed batteries. Battery charge management to extend life of battery: limit depth of discharge. When charged but not used, employ —float mode to prevent leakage currents from discharging battery. Pulsing to break up chunks of lead sulphate. Trickle charging to equalize charges of series-connected cells. So, it is necessary to prevent deep discharge of battery. we use LED light for street lightening with proper charge management of the battery

A LED device consists of cathode, anode, LED chip, wire bond, epoxy lens and reflectors. It comes in several colors which are predetermined by the semiconductor material used in manufacturing. The most common specification that comes with a small LED is its voltage and current rating. A forward voltage is required to initially drive the LED on and the maximum forward current rating limits the amount of current that can flow through it without damaging the LED. Another type of current rating can be given along with the LED that gives the value at which the LED will be brightest. However we should remember that the LED current is dependent on the ambient temperature and any change in voltage. A small change in voltage can lead to big change in current thus damaging the circuitry and the overall lighting system. To avoid this problem LEDs, with a DC power supply, require a driver circuit which will be discussed later in this section. For evading short circuit issues the LEDs are connected in series with a resistor. The calculation for the resistance is shown below:

$$R = (V_s - V_{LED}) / I_{LED}$$

V_{LED} and I_{LED} will be given by the rating on the LED lamp and the V_s which is power supply will be controlled by the driver circuit. A complete LED lighting system consists of LEDs, optical system, thermal system and electrical system. This integrated successfully can provide good illumination besides being energy efficient and economically viable. LED produces directive light thus to fit it according to our purpose it might need several optical considerations and systems such as lens, reflectors etc. The performance of an LED is highly altered by the effect of its junction temperature, which in turn influences the LED current, light output and leads to a shorter life. A very good

heat sink should be used to minimize the temperature. As mentioned earlier, a small fluctuation in voltage can lead to a huge change in LED current; we require a driver circuit to maintain a stable current all throughout. For this project we are taking into account a DC to DC converter (Switching regulator type).

Since we only want to limit the voltage to the maximum voltage supply in accordance with the LED current, temperature and light intensity required, a buck type converter is suitable. This type always yields a lower output voltage than the input and through pulse width modulation from a microcontroller, the on time of the voltage can be varied to achieve different intensities.

3.1 BOOST CONVERTER

There has been an incredible development in the field of electrical components in recent years. The competition is to make things portable and flexible so that the usage will be more with less effort. As stated for electrical components to run, the power consumption is the major factor. For the optimum usage of electronic components, dc to dc converter plays a major role. The dc to dc converter can be used for many electronic components and it is widely used in telephone components and many other electronic devices. The purpose of dc to dc converter is to convert (i.e. to step up) the voltage from one value to the other and to perform regulation for the electronic circuit. In general the boost converter is the simplest way to increase the voltage of a DC supply which is not possible with the help of the transformers and promises high efficiency. Consider the linear regulator as shown in Figure 1. Here, the source voltage V_s is which is to be step down to voltage V_L across the resistor R_1 which means the voltage across R_L must be dropped which intern results in waste of power in the form of heat. This problem can be overcome by using Boost Converter as it uses switch (Diode) to operate in ON and OFF state

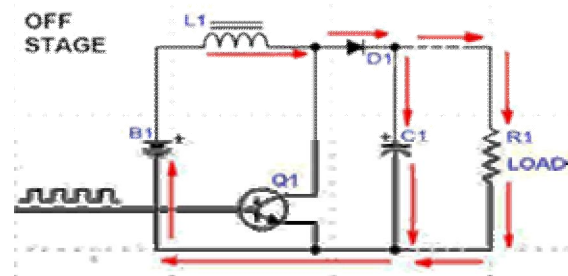

The dc-dc boost converter topology is most widely used power management and microprocessor voltage-regulator applications. These applications require high frequency and transient response over a wide load current range. They can

convert high voltage into low regulated voltage. Boost converter can be used in computers, where we need voltage to be stepped down. Boost converter provides long battery life for mobile phones which spend most of the time in stand-by state. When the switch is ON the inductor gets charged to its maximum level, because of its flexibility of ON and OFF states it can be switched to OFF state when inductor charges to its maximum capacity. With this feature the usage of heat sinks and cooling agents can be avoided. Hence, because of its advantage we opt for buck converter rather than a linear regulator.

The name “Boost Converter” itself indicates that the input voltage is boosted or increased and high voltage appears at the output. A boost converter or step up voltage regulator provides non isolated, switch mode dc-dc conversion with the advantage of simplicity and low cost. Figure 2, shows a simplified dc-dc boost converter that accepts a dc input and uses pulse width modulation of switching frequency to control the output voltage. The buck converter consists of Source Voltage ‘ V_s ’, Diode, Inductor ‘ L ’, Inductor Resistance ‘ R_L ’, Capacitor ‘ C ’, and Capacitive Resistance ‘ R_c ’ all connected to a Load.

Switch mode power supply is generally used to provide the output voltage which is higher than the input voltage to the load from an intermediate DC input voltage bus or a battery source. A simplified boost converter point of load which has power supply from a switch mode buck converter is shown in Figure.3. The buck converter consists of main power switch, a diode, a low-pass filter (L and C) and a load. The basic boost converter operates in ON and OFF states. In ON state i.e. when the switch is closed the current flows through inductor from the voltage source, where inductor gets charged to its peak level. Where as in OFF state i.e. when switch is open the inductor acts as additional voltage source to the supply thus boosting its voltage to the load.

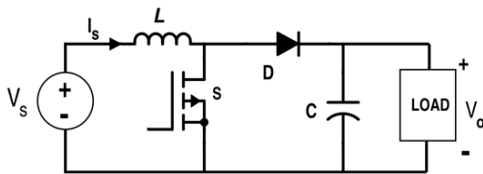

Fig 2.2 Boost Converter

3.2 MOSFET DRIVER CIRCUIT (TLP 250)

It is used to amplify the gate pulse voltage to MOSFET. Threshold needs by pushpull amplification. The schematic of TLP250 is shown below. It should be noted that the V_{cc} must be between 12V to 24 V which is the operating range of the driver. A capacitor is connected across the supply

pins to filter the ripples in the supply .Pin 2 and 3 forms the input. Pin 6 is output which is connected to the gate of the MOSFET.

Pin Configuration (top view)

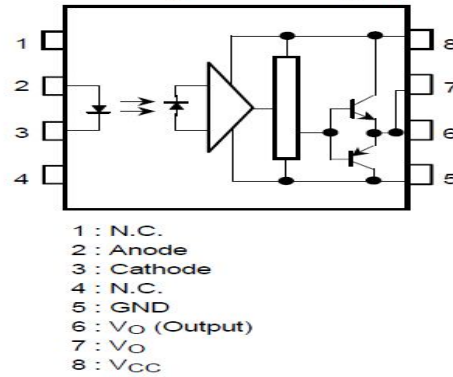

IV. CONCLUSION

The Battery can be charged by Solar power. It was constructed such that the conventional need for inverter or utility power source is eliminated. As known due to prior knowledge that the street light system needs a charge controller to prevent the battery from damage and also a sensor to help in the automatic switching, the equipment was fabricated along with a switching circuit which activates and deactivate the system as well as a charge controller unit that prevents the battery from overcharging. The system was also built to conserve energy with the use of a light emitting diode lamp (LED lamp) to replace other lamps such as the fluorescent lamp which might reduce the efficiency of the battery. Also, the use of an inverter was eliminated since the solar panel supply direct current (dc) necessary to charge the battery without the need for a conversion to an alternating current (ac). The main improvement of this project has been the elimination of a dc to ac inverter unit.

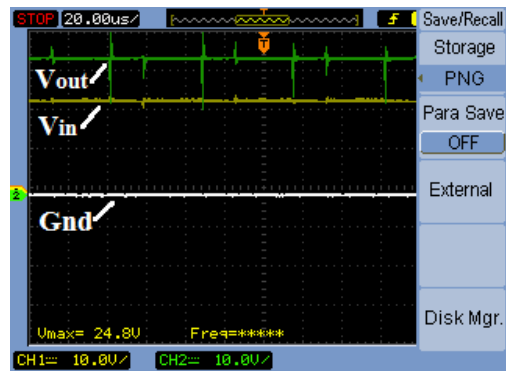

ACKNOWLEDGMENT

The experiment work for this paper was done at Saranathan College Of Engineering.

REFERENCES

- [1] Chetan Singh Solanki, Solar photovoltaics-Fundamentals, Technologies and applications , PHI learning private limited,2015.
- [2] H.Uang,B.J,Hsu.p.c , "A high performance stand alone solar PV power system for LED light " , IEEE 35th photovoltaic specialist conference(PVSC),2010,pp. 2346-2348
- [3] M.A.Dallacosta,L.Schuch , "Autonomous street lighting system based on solar energy and LEDs " , IEEE 35th photovoltaic specialist conference(PVSC),2010,pp. 1143-1148.