

# Analysis of Fatigue Performance of Single Cylinder IC Engine-A Review

Prof. S. V. Wankhede<sup>1</sup>, S. Rothe<sup>2</sup>, K. Kulkarni<sup>3</sup>, B. Shinde<sup>4</sup>, S. Patil<sup>5</sup>

<sup>1, 2, 3, 4, 5</sup> Department of Mechanical Engineering

<sup>1, 2, 3, 4, 5</sup> Sinhgad Institute of Technology, Kusgaon (Bk), Lonavala,

**Abstract-** The crankshaft is a component which is of prime importance to an engine. The function of crankshaft is to convert the reciprocating displacement of the piston into a rotary motion. The major cause of failure of crankshaft is fatigue resulting into cracks on the surface of crankshaft and effect of residual stresses. The crankpin is subjected to several types of stresses but the more common causes are cyclic stresses and torsional stresses. In this paper, the fatigue analysis of single cylinder petrol engine crankshafts of engine is reviewed by analytical method and finite element method. The 3D models of crankshafts were developed in CREO 1.0. Fatigue Performance of a single cylinder petrol engine depends upon various parameters such as material, manufacturing process, number of stress cycles, vibrations, and engine capacities.

**Keywords-** Crankpin, Fatigue failure, FEM, Stress analysis.

## I. INTRODUCTION

Crankshaft is a crucial component in any type of IC-engine. It converts reciprocating motion of piston into rotary motion. Generally the materials used for crankshaft is steel and its alloys. It undergoes the continuous fluctuating loads due to reciprocating motion of piston. It is connected to the connecting rod by using crankpin, so the design of crankshaft and crankpin affects largely on reliability and life of engine. Crankshaft is commonly designed according to number of pistons and the firing order of engine. The most common cause of crankshaft failure is fatigue phenomenon, hence designing the crankshaft and crankpin to reduce fatigue failure and improve its fatigue life is important. Various modelling platforms are used for designing the crankshaft such as creo-parametric 1.0 for modelling and ANSYS workbench 14.5 for fatigue and structural analysis. These tools reduce the testing cost of components and also provide very accurate results for fatigue analysis without use of any experimental setup.

## II. LITERATURE REVIEW

Bhumesh J. Bagde et al (2013) had described the methodology for modelling, analysis and effect of stresses on selection of proper material for the crankshaft of single

cylinder engine. In this paper the author emphasises on the modelling of crankshaft using PRO-E Wildfire 4.0 and finite element method for the analysis of crankshaft. The five different materials used for analysis of crankshaft are EN9, SAE 1045, SAE 1137, SAE 3140, and Nickel Cast Iron so as to find optimal material which gives good results and better fatigue properties. <sup>[1]</sup>

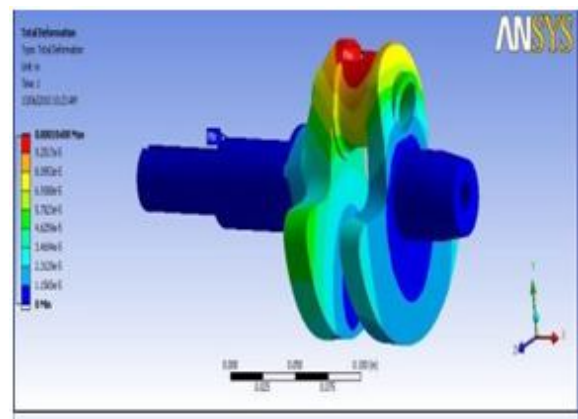

Fig 1. Structural Analysis of crank shaft (Deformation)

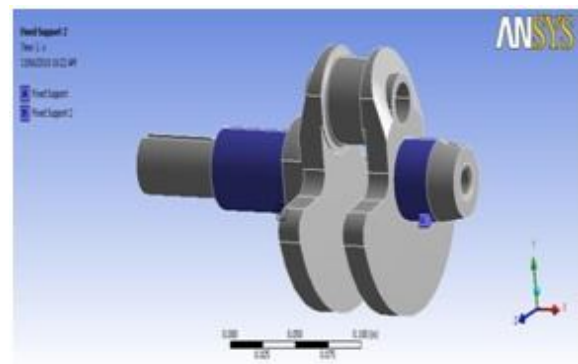

Fig 2: Boundary conditions applied on Crankshaft

M. Senthilkumar et al (2014) focused on study of crankpin failure in IC engine. The author carried out the stress analysis of crankpin using ANSYS software. The maximum stress value is obtained at the points where the crankpin makes the contact with connecting rod. The region near to lubrication hole is having maximum stress concentration. Later the experimental testing of crankpin is done and the variation in

chemical composition is found in failed and un-failed components. [2]

ShwetaAmbadasNaik (2015) emphasises on the review of failure analysis of the crankshaft by finite element analysis method. The stress analysis and model analysis of 4-cylinder engine is discussed. In this study she found all the crankshaft failed from the same region, that first failure of crankpin occurs then flywheel and other components fails.

The various forces acting on the shaft but failure takes place in two positions, bending and twisting. Firstly, failure may occur at the position of maximum bending; this may be at the center of the crank or at either end. In such a condition the failure is due to bending and the pressure in the cylinder is maximal. Second, the crank may fail due to twisting, so the connecting rod needs to be checked for shear at the position of maximal twisting. The pressure at this position is the maximum pressure, but only a fraction of maximal pressure.

Majority of steel crankshaft failure occurs due to fatigue failure, which may originate at the change of cross-section such as at the lip of oil hole bored in the crankpin. Vibration is one of the causes of failure of crankshaft. If the engine is running with heavy vibration especially torsional vibration, it may lead to crack in the crankpin and journal. One of the reasons to fail the crankshaft due to insufficient lubricant. If the lubrication of bearing in the crankshaft is starved, it may lead to wipe out of the bearing and failure of the crankshaft takes place.

Due to extreme pressure, the crankshaft may slip or even bent. Cracks can develop at the fillet between the journal and the web, particularly between the position corresponding to 10 o'clock and 2 o'clock when the piston is at T.D.C. [3]

Osman Asi (2006) had described failure analysis of a crankshaft made from ductile cast iron. In which he studied the failure analysis of a petrol engine crankshaft used in a truck, which is made from ductile cast iron. The crankshaft was found to break into two pieces at the crankpin portion before completion of warranty period. The crankshaft was induction hardened. [4]

S.M.Sorte et al (2013) had described the stress analysis and design optimization of single cylinder crankpin of TVS Scooter. Three dimensional models of crankshaft and crankpin is designed by using PRO-E and then imported into ANSYS to analyse stress on crankpin. By performing analytical calculation it is concluded that the value of

maximum bending stress and maximum shear stress is more than allowable stress values which causes failure. [5]

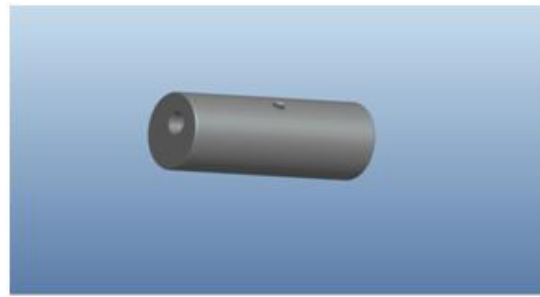

Fig.3 Model of crank pin

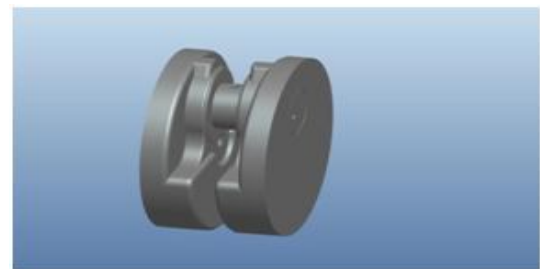

Fig.4 Model of crankshaft assembly



Fig.5 Crankshaft of TVS pep

F.H. Montazersadgh et al experimentally found there are two different load sources in an engine; inertia and combustion. These two load source cause both bending and torsional load on the crankshaft. The maximum load of 3.5 bar occurs at the crank angle of 355 degrees for this specific engine. At this angle only bending load is applied to the crankshaft. Considering torsional load in the overall dynamic loading conditions has no effect on von Mises stress at the critically stressed location. The effect of torsion on the stress range is also relatively small at other locations undergoing torsional load. Therefore, the crankshaft analysis could be simplified to applying only bending load. Superposition of FEM analysis results from two perpendicular loads is an efficient and simple method of achieving stresses at different loading conditions according to forces applied to the crankshaft in dynamic analysis. Experimental and FEA results showed close agreement, within 7% difference. These results indicate non-symmetric bending stresses on the crankpin

bearing, whereas using analytical method predicts bending stresses to be symmetric at this location. The lack of symmetry is a geometry deformation effect, indicating the need for FEA. [9]

JaiminBrahmbhatt and Prof. Abhishekchoubey carried out the design and analysis of crankshaft for single cylinder 4-stroke diesel engine. In this paper a dynamic simulation is conducted on a crankshaft from a single cylinder 4- stroke diesel engine. This analysis is done for finding critical location in crankshaft, stress variation over the engine cycle and the effect of torsion and bending load. Von-mises stress is calculated using theoretically and FEA software ANSYS. The relationship between the frequency and the vibration modal is explained by the modal and harmonic analysis of crankshaft using FEA software ANSYS. Fig-5 shows the crankshaft model in ANSYS and Fig-6 shows meshed model of crankshaft. Tetrahedrons element is used for meshing Define boundary condition for analysis, after applying the Load, Run the analysis. Vonmises stresses are calculated. [11]

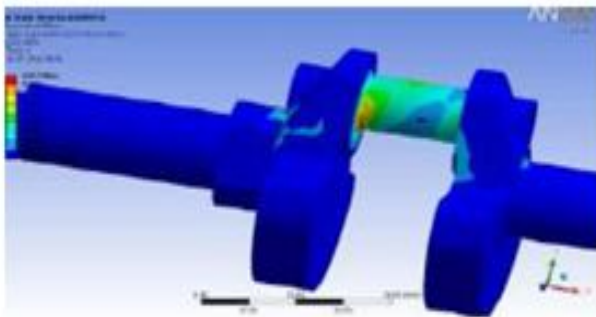
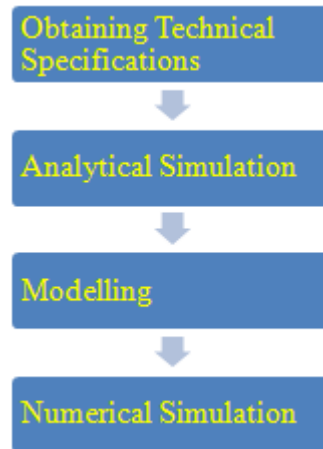

Fig.6 von-Mises stresses

### III.METHODOLOGY

This paper aims to stress analysis of crankshaft of single cylinder Internal Combustion engine. Initially the dimensional analysis is carried out which is followed by the detail modeling of crankshaft using creo-parametric 11.0 modeling software. Later on the analytical calculation are carried out for finding gas force, max. Bending moment, section modulus and von Mises stresses. The finite element analysis is performed using ANSYS Workbench 14.5

The following methodology could be adopted:



### IV. ANALYTICAL METHOD

#### THEORY

Here formulas are shown in order to obtain values for Gas Force, Bending Moment, Section Modulus and Torque. Finally all these values are used in order to calculate the Von Misses Stresses.

- 1) Gas Force acting on the Piston,  

$$F_p = p \times A$$
- 2) Maximum Bending Moment on the Crankpin:  

$$M_{\max} = (F_p/2) \times (l_c/2)$$

By the given dimensions of the crankpin,  
 $D_c =$  Diameter of the crankpin  
 $L_c =$  Length of the crankpin
- 3) Section Modulus of Crankpin:

$$Z = \pi/32 \times d_c^3$$

- 4) Torque Obtained At Maximum Power Of Given Engine:

$$P = (2 \times \pi \times N \times T) / 60$$

- 5) Von Misses Stresses Induced:  
 Let,

$$K_b = 1$$

$$K_t = 1$$

Equivalent Bending Moment:

$$M_{ev} = \sqrt{(K_b \times M_{\max})^2 + (\frac{3}{4} \times (K_t \times T)^2)}$$

$$\sigma_{von} = M_{ev} / Z$$

- 6) Deformation:

$$\text{As Strain } \epsilon = \sigma / E$$

Here stress =

$$\sigma = F_p / A_c$$

Surface Area of crankpin

$$A_c = \pi \times d_c \times l_c$$

Deformation

$$\delta = \epsilon \times l_c$$

## V. CONCLUSION

Above all researchers gives the idea about designing of the Crankshaft. They explained about the various causes of failure of crankshaft and sources of damage the journal also, Most of the researchers used the Pro/E software, PTC creo 1.0 and solidworks for the modeling and ANSYS Workbench software for analysis. These can be used for designing and analysis of crankshaft in Automobile. In some paper, dynamic simulation is conducted on crankshaft. The stress analysis and modal analysis of crankshaft are discussed using FEM. The results would provide a valuable theoretical foundation for the optimization and improvement of engine design. These when put to further use would lead to improvement in the design parameters and fatigue performance of engines

## VI. FUTURE SCOPE

The methods involved in this paper can utilized for further studies. Fatigue analysis of single cylinder petrol engines can be carried out using these methods to determine the relative fatigue lives and to derive a critical engine capacity which will have max. Fatigue life as well as appropriate power for a specific power range.

This procedure could be adopted to more to perform relative studies for various parameters. One such study could involve varying of parameters like crankpin length, diameter of crankpin, material of crankpin, engine capacity, and manufacturing processed so as to determine the relative performances.

## REFERENCES

- [1] Bhumesh J. Bagde<sup>1</sup>, Laukik P. Raut “Finite element analysis of single cylinder engine crank shaft”, International Journal of Advances in Engineering & Technology, May 2013. ©IJAET ISSN: 2231-1963 981
- [2] M. SenthilKumar\*, Dr.S.Ragunathan, M.Suresh, V.R.Srinivashan, “A Study of Crankpin Failure in I.C.Engine”, Mechanical Engineering: An international journal (MEIJ), Vol. 1, No. 3, November 2014.
- [3] Ms.ShwetaAmbadasNaik, “Failure analysis of crankshaft by finite element method-a review”, International Journal of Engineering Trends and Technology (IJETT) – Volume 19 Number 5 – Jan 2015.
- [4] Osman Asi, “Failure analysis of a crankshaft made from ductile cast iron engineering failure analysis”, Vol.No. – 13 (2006), Page No- 1260–1267
- [5] S.M.Sorte, S.M.Sheikh, “Stress analysis and design optimization of crankpin”, International Journal of Scienceand Modern Engineering (IJISME) ISSN: 2319-6386, Volume-1, Issue-4, March 2013.
- [6] M. Fonte\* et al, “Crankshaft failure analysis of a motor vehicle”, Engineering Failure Analysis, Vol. No. – 35(2013), Page No- 147–152.
- [7] Mr. Anant B. Khandkule\*, Prof. Prasad D. Kulkarni, “Fatigue Phenomenon in Single CylinderEngine Crankshaft”, IJSART - Volume 1 Issue 10 –OCTOBER 2015 ISSN [ONLINE]: 2395-1052.
- [8] M. Senthil Kumar\*, Dr.S.Ragunathan, M.Suresh, “Fatigue analysis of coated i.c. Engine crankshaft”, international journal of research in aeronautical and mechanical engineering ISSN (online): 2321-3051, vol.2issue. 9, September 2014.
- [9] F. H. Montazersadghand A. Fatemi, “Dynamic load and stress analysis of a crankshaft” 2007-01-0258, theuniversity of Toledo.
- [10] J. Brahmhbhatt and Prof. AbhishekChoubey, “Design and analysis of crankshaft for single cylinder 4-strokediesel engine,” international journal of advanced engineering research and studies, e-issn2249–8974.
- [11] M. Jian, L. Yong-qi, L. Rui-xiang, Z. Bin, (2010), “Intension analysis of 3-d finite element analysis on 380diesel crankshaft” International Conference on Computational and Information Sciences, pp 1269-1272.
- [12] M.K.Paswan and A.K.Goel, (2008) “Fatigue testing procedure of 6 cylinder diesel engine crankshafts,”ARISER Vol.4 No.3 (2008) 144-151.