

Reducing Major defects in Radiators Manufacturing

Kumar P.¹, Sonawane B.S.², Sontakke R.R.³, Surve S.B.⁴, Wasnik A.R.⁵

^{1, 2, 3, 4, 5} Department of Mechanical Engineering

^{1, 2, 3, 4, 5} Sinhgad Institute of Technology, Lonavala, Maharashtra-410401, India.

Abstract- Radiators are heat exchangers used to transfer thermal energy from one medium to another for the purpose of cooling and heating. While manufacturing many defects occurs. The aim of this paper is to apply the quality tools to find out the root causes of the quality problems related to manufacturing of Radiator. The modes of defects on production line are investigated through direct observation on the production line and statistical tools like Check sheets, Histogram, Pareto analysis, Cause and Effect diagram are used in enhancing the process by continuous monitoring through inspection of the sample an always change for betterment. The work shows utility of quality tools to find the root causes of the problems and eliminate them.

Keywords- Radiator, Manufacturing Process, Seven QC Tools, Fishbone Diagram, FTR Percentage.

I. INTRODUCTION

Radiators are heat exchangers used to transfer thermal energy from one medium to another for the purpose of cooling and heating. The radiator is always a source of heat to its environment, although this may be for either the purpose of heating this environment, or for cooling the fluid or coolant supplied to it, as for engine cooling.

Radiator assembly consists of three main parts core, inlet tank and outlet tank. Core has two sets of passage, a set of tubes and a set of fins. Coolant flows through tubes and air flows between fins. The hot coolant sends heat through tubes to fins. Outside air passing between fins pickups and carries away heat. Performance of cooling system is influenced by factors like air and coolant mass flow rate, air inlet temperature, coolant fluid, fin type, fin pitch, tube type and tube pitch etc. The problems arising in the manufacture of radiator are fin bond failure, Clinching open, internal deposit, fin damage, cracked plastic tank, Nail tank, Tank broken, flux and dust on header plate, blown tank to header seal, & loose side piece. Heat transfer is commonly encountered in engineering systems and other aspects of life. Many ordinary household appliances are designed, in whole or in part, by using the principles of heat transfer. Some examples include the electric or gas range, the heating and air-conditioning system, the refrigerator and freezer, the water heater, the iron, and even the computer, the TV, and the DVD player. Of course, energy-efficient homes are designed on the basis of

minimizing heat loss in winter and heat gain in summer. Heat transfer plays a major role in the design of many other devices, such as radiators, solar collectors, various components of power plants, and even spacecraft. One of the important device used for heat transfer is “Radiators”[3].

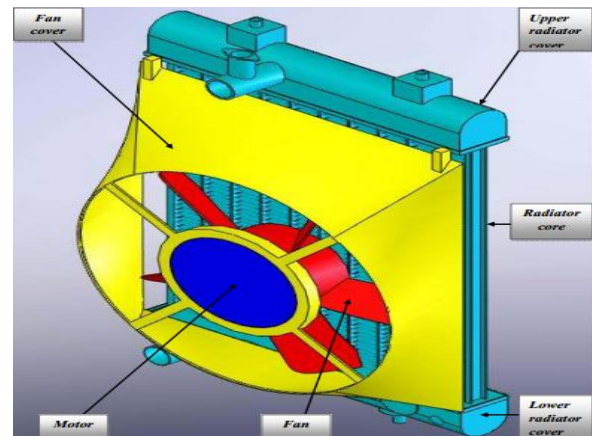

Fig 1: Radiator Assembly

II. PRODUCTION PROCESSES OF RADIATOR

- Tube mill forming-In this process small radiator tubes are form as per requirements of radiators.
- Press machining for header plate.
- Fin form machine.
- Radiator core assembly-In RCA assembly of header plate fins and tube are takes place. In this process mainly H/P tube joint defects are form.
- Brazing-In brazing Flux on H/P, adherence NG defects are form.
- Clinching-In clinching Tank Broken and nail cut form.
- Air/Water leak testing.

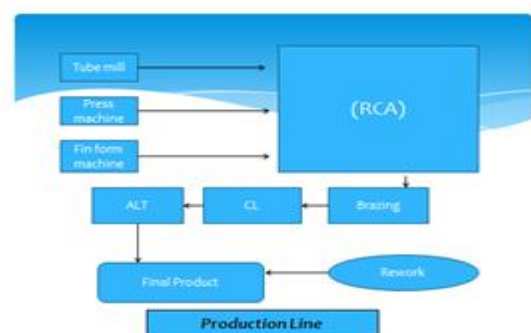

Fig. 2: Production Line Diagram

III. MAJOR DEFECT OCCURS IN RADIATOR

A. Tube Radiator Leakage:-

Radiator leakage is the defects occur during brazing between fins and header plate.



Fig. 3: Radiator leakage

B. Flux on header plate: -

The flux was applied on substrate by dipping, and then dried with blowing warm air. An improper amount of flux can produced brazing joint with high porosity and flux residue, therefore appropriate flux must be given.



Fig. 4: Flux on H/P

C. Clinching open:-

These defects occur due to improper fixing between header plate nails and radiator tank.

IV. SEVEN QUALITY TOOLS

Continuous quality improvement process assumes, and even demands that team of experts in field as well as company leadership actively use quality tools in their improvement activities and decision making process. Quality tools can be used in all phases of production process, from the beginning of product development up to product marketing and customer support. At the moment there are a significant number of quality assurance and quality management tools on disposal to quality experts and managers, so the selection of most appropriated one is not always an easy task. In the

conducted research it is investigated possibilities of successful application of 7QC tools in several companies in power generating and process industry as well as government, tourism and health services. The seven analyzed quality tools are:

- Flow chart
- Cause-and-Effect diagram
- Check sheet
- Pareto diagram
- Histogram
- Scatter plot
- Control charts

Furthermore, as a part of the research is analysis of possibilities of systematic use of quality tools in process industry, what is show in this paper on simple example.

V. FISHBONE DIAGRAM

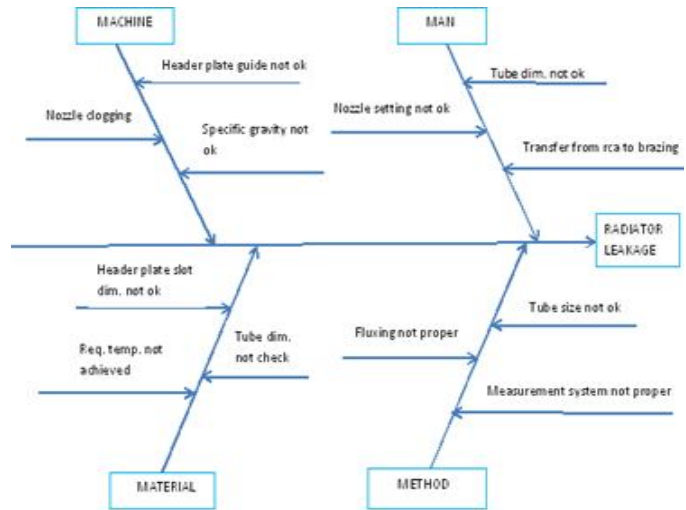

Fig. 5: Fishbone Diagram for Radiator leakage

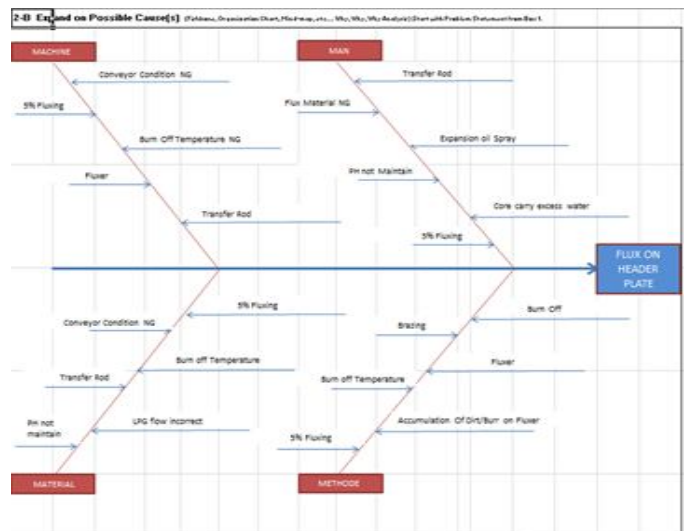

Fig.6: Fishbone Diagram of Flux on H/P

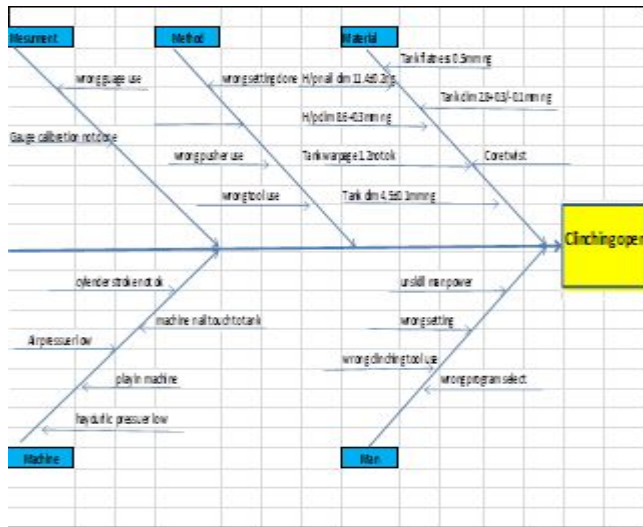

Fig.7:Fishbone dig. for cinching open

VI.SOLUTION FORPROBLEMS ENCOUNTERED IN DIFFERENT PARAMETERS

A. Radiator Leakage:-

The big problem in radiator is the leakage to minimize this we have to focus specially on H/P and tube joint in brazing process.In this work an attempt is made to find out the temp-displacement analysis of a radiator tubeelement from temp. range 35°C- 620°C of a Brazing process to prevent the leakage as it start from brazing area temperature and just before the melting point of material as around 650°C, which is the major problem facing in the heat exchanger at header and tube joints. A temp-displacement analysis is carried out to find out the temperature and thermal expansion of radiator tubes (consider 5different tube dimensions).

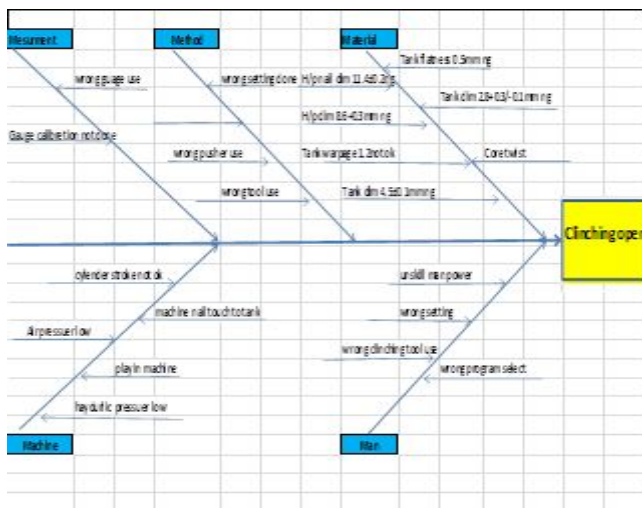

Fig.8:Tube Dimension

Aluminium radiator cores are brazed in a furnace to join the tubes, fin, and headers. This brazing process is

commonly referred to as CAB (Controlled Atmosphere Brazing). Priority to brazing the cores must be cleaned and fluxed. The most common way to apply the flux is to mix the flux with water and spray it onto the core. A flux machine typically has multiple zones including a spray application zone, and dryer section. Tube forming is the process of forming the flat sheet metals into rectangular cross sectioned tubes, this tube forming will be performed in tube mill machine and According to a preferred embodiment the header is formed in a single sheet of metal by an expensive stamping operation[8].

Brazing-

Brazing is a metal-joining process whereby a filler metal is heated above melting point and distributed between two or more close- fitting parts by capillary action. The filler metal is brought slightly above its melting temperature while protected by a suitable atmosphere, usually a flux. It is similar to soldering, except the temperatures used to melt the filler metal are higher. According to before analysis, the perfect brazing gap for header joints and tubes is 0.03 to 0.08 mm.or it should not be greater than 0.08 mm.In this project we are concentrating on the leakage occurring between radiator header and tube joint. If the gap between the header and tube joint was perfectly made than there won't be any leakage between header and tube. The perfect gap required between header and tube is 0.03mm to 0.08. This is the good brazing gap required. If the gap is 0.03 to 0.08mm between the header and tube joint will get the perfect brazed together.



Fig.9:Gap size location

Material and Properties-

For doing this analysis we chosen the properties of A3003 material are listed below:

Thermal conductivity = 237 w/mk

Density = 2700 kg/m3

Poisons ratio = 0.35

Coefficient of thermal expansion = 0.000023 (m/m°C)

Then with the help of formulation the change in length can be calculated as-

$$dl = L_0 \alpha (t_1 - t_0)$$

For dim.1.83mm-

$$dl=1.83*0.001*0.000023*(620-35)=0.02mm.$$

Above expansion length is same for all the dimension approximately. In this analysis process we are finding expansion of the based on the temperature variation from 35°c to 620° c.That’s why we selected the module temp-displacement study state. Which helps out to find the expansion of the tube based on the temperature varies from 35°c to 620° c.By analysing the tube cross section with 5 different iterations we got the perfect tube size is 1.89 to 1.95mm.Co efficient of thermal expansion = 0.000025 μ/m k In this analysis process we are finding expansion based on the temperature variation from 35°c to 620° c. also depend on inserting dimension. This perfect tube dimension forms good joint with header slot when the tolerances are minimum (1.97mm) or maximum (2.07mm).

By using iteration i.e trial method, on the 5 different dimensions we found out the perfect tube size which makes perfect joint with the header slot. The analysed tolerance results were listed below:-

Dimension 1.83 mm-

When we consider the minimum tolerance (1.97mm) of the header slot dimension, then the gap/ side coming 0.06mm, and this is the good brazing gap/side for the particular material (A3003). When we consider the maximum tolerance (2.07mm) of the header slot dimension, then the gap/ side coming 0.11 mm, and this gap was beyond the good brazing gap/side for the particular material (A3003).

Table 1:-Analysis of Tube Dimension

Analysis Report					
Sr. No.	Major Axis Tube Dim.	After Expand	H/P Slot dim.	Gap	Result
1)	1.83	1.83+0.02=1.85	2.07-1.85=0.22 1.97-1.85=0.12	0.11 0.06	Not Ok Ok
2)	1.87	1.89	0.18 0.08	0.09 0.04	Not Ok Ok
3)	1.89	1.91	0.16 0.06	0.08 0.03	Ok Ok
4)	1.90	1.92	0.15 0.05	0.075 0.025	Ok Ok
5)	1.91	1.93	0.14 0.04	0.07 0.02	Ok Ok

From above analysis acceptable tube size is at no. 3,4 and 5 so we can conclude from above analysis,one we can directly make tube size from above 1.89mm as its major axis, also can make jig in range of 1.89 to 1.95mm for to reduce cycle time or second make expansion tool for expansion for range from lower value of tube size to between 1.89 - 1.95mm for brazing gap 0.03-0.08mm..so we can use this tubes for brazing operation to avoid leakage of radiator and mainly to reduce rejection percentage which directly affect the cost.Below table shows approximately analysis of rejection and cycle time how it has affect that showed but in the ratio and by considering anyone model of radiator.So by above analysis we can make revision of tube tolerance limit as approximately 1.92±0.03mmto reduce leakage in radiator or can make expansion tool as for range 1.89-1.95mm.

Table 2:-Analysis of Rejection and Manufacturing Cycle-time

Rejection			
Sr.No.	First FTR%-	Second FTR%-	Change-
1)	Overall 60 % (Supposed.) approx.	Overall 65% approx.	Approx. 5%
Cycle Time			
Sr No.	Cycle Time Ratio-		
1)	5:4.		

VII.CONCLUSION

In this paper we studies all the process for manufacturing of a radiator and the problems in their manufacturing process specially radiator leakageandimproved them by qualitative and trial i.e iteration method asconsidering perfect brazing gap from 0.03 to 0.08mm between the header and tube joint.From that we have setted new tolerance limit as 1.92±0.03mm.So as defect in radiator decrease, rejection rate also reduced and also the cycle time.

ACKNOWLEDGMENT

It is our privilege to acknowledge with deep sense of gratitude to our Project Stage-I guide, Prof. A.R. Wasnikfor their valuable suggestions and guidance throughout our course of study and timely help given to us in the completion of Project Stage-I.

We’re highly obliged to Dr. V.V. Shinde, Head of Department, Dr. M. S. Gaikwad, Principal, Sinhgad Institute of Technology,and entire staff of Mechanical Engineering department for their kind cooperation and help. We also take this opportunity to thank“TATA TOYO RADIATOR LTD.”and our guideMr.ManishsinghS.Dixit,Operation Manager,TATA Toyo Radiator

Ltd.,Mr.AmitkumarC.Mehta,Mr.ArifJ.Shaikhwho backed our interest by giving suggestions and all possible help.

REFERENCES

- [1] Shabtay Y.L., Ainali M., Lea A., "New brazing processes using anneal-resistant copper and brass alloys", *Materials and Design* 25 (2004), 14 (2004), pp 83–89.
- [2] W. Fu W. , Song X.G. , Hu S.P., Chai J.H. , " Brazing copper and alumina metallized with Ti-containing Sn0.3Ag0.7 Cu metal powder", *Materials and Design* , 87 (2015) , pp 579–585 .
- [3] Prof.G.Paliska,Prof.D.Palvetic,"Quality tools systematic use in process industry" *Journal of achievement in materials and manufacturing industry*,pp 101-110.
- [4] Oliet C., Oliva A., Castro J., " Parametric studies on automotive radiators" , *Applied Thermal Engineering*, 27 (2007) ,pp. 2033–2043.
- [5] Qina G., Leib Z., Sua Y., Fua B., "Large spot laser assisted GMA brazing–fusion welding of aluminum alloy to galvanized steel", *Journal of Materials Processing Technology* , 214 (2014) ,pp. 2684–2692.
- [6] Hasap A., Noraphaiphaks N. , Kanchanomai C.," Torsional strength and failure of copper alloy brazing joint", *Engineering Failure Analysis*, 48 (2015),pp. 174–184.
- [7] Taheri-Garavand A., Ahmadi H., " An intelligent approach for cooling radiator fault diagnosis based on infrared thermal image processing technique", *Applied Thermal Engineering* ,87 (2015) ,pp. 434-443 .
- [8] Prof.A.Munniapan"Design Modification and analysis of header tube joint in heat exchanger" *International journal of innovative research in science, engineering*,pp.100-115.
- [9] Glembinl J., Büttner C., , "Thermal Storage Tanks in High Efficiency Heat Pump Systems – Optimized Installation and Operation Parameters" *Energy Procedia* ,73 (2015) pp 331 – 340.
- [10] Wang, C.,Kam H., Cheong W." Effect of tool eccentricity on the joint strength in mechanical clinching process" *ProcediaEngineering* , 81 (2014) ,pp 2062 – 2067.
- [11] Hea X.,Zhang Y., Cun H., "Vibration Measurements of Clinched Joints" *Procedia CIRP* 26 (2015) ,pp 208 – 211.
- [12] Prof..Solanki J.,Prof.Acharya H. "Optimization of Defects in Encountered manufacturing of radiator" *International journal of advance engineering and Resesarch Development* ,scientific journal of impact factor, pp 134-139.
- [13] Myhren J., Holmberg S.," Improving the thermal performance of ventilation radiators : The role of internal convection fins" *International Journal of Thermal Sciences* ,50 (2011) , pp 115-123 .