

# Automatic Solar Tracking System to Maximize Power Extraction

Dr. P. Prem Kumar<sup>1</sup>, P. Harish Kumar<sup>2</sup>, M. Indhu Priyanga<sup>3</sup>, B. Saranya<sup>4</sup>, M.Rahul<sup>5</sup>

<sup>1, 2, 3, 4, 5</sup> Department of EIE

<sup>1, 2, 3, 4</sup> K.S.Rangasamy college of Technology, Thiruchengode, Tamilnadu

**Abstract-** *In this technological world the need for renewable energy resources has been very essential rather than non-renewable resources, because cost of the non-renewable resources sums to be a larger one and it will not provide an eco-friendly environment. So, in this concept we introduce the Parabolic Solar Tracking System instead of the flat solar tracking system which is very common in our day today life. By implementing parabolic solar tracking system, which uses the multi-junction solar cells with parabolic mirror reflectors the efficiency can be improved up to 39.2% compared to the single-junction cells. This enhanced feature is due to the infinite number of junction in the multi-junction solar cell and the shape of the reflectors that is designed. The dual-axis tracking system is controlled by PIC 18F4550 microcontroller depending upon the control signal given by LDR.*

**Keywords-** Renewable energy, Eco-friendly, Parabolic reflector, LDR.

## I. INTRODUCTION

The main motive to work on this project is to provide a clean environment where the life of the people on the earth should not be disturbed by the surroundings they live in and to replace the carbon based energy resources like oil, gas and coal which leads to global warming. One of the major problem which is faced mostly by Indians in their day-to-day life is demand for electricity without it they can't lead their life. The development in technology had put them into the situation because everything around them is technology which needs power supply to run them.

It is a free, non-polluting, inexhaustible energy, solar energy is ideal for generating electricity. Currently, generating electricity by solar energy is inefficient and also the cost of solar panel is considerably high. So our project focuses on improvement of solar cell's efficiency by introducing a multi-junction PV cell. A solar cell receives the sun light when it is perpendicular to the sun's rays, but the sunlight direction changes regularly with changing seasons and weather. The solar tracking system is designed in such a way in order to increase the unit area illumination of sunlight on solar cell. The design mechanism holds the glass fiber reflector along with solar cells and allows the reflector to perform a dual axis

rotation to track the sun's movement during the day time and improve the overall electricity generation. This system can achieve the maximum illumination and energy concentration by using a multi-junction solar cell, therefore, it has great significance for research and development.

Solar energy, radiant light and heat from the sun, has been harnessed by humans since ancient times using a range of ever-evolving technologies. Solar radiation, along with secondary solar power resources such as wind and wave power, hydro-electricity and biomass, account for most of the available renewable energy on earth only a fraction of the available solar energy is used.

Normally, solar energy is generated by using either solar tracking system or flat solar panel system which uses large number of cells. The proposed system uses concentrated cell which harvests maximum solar energy by using a minimum number of cell.

## II. METHODOLOGY

### A. Block diagram

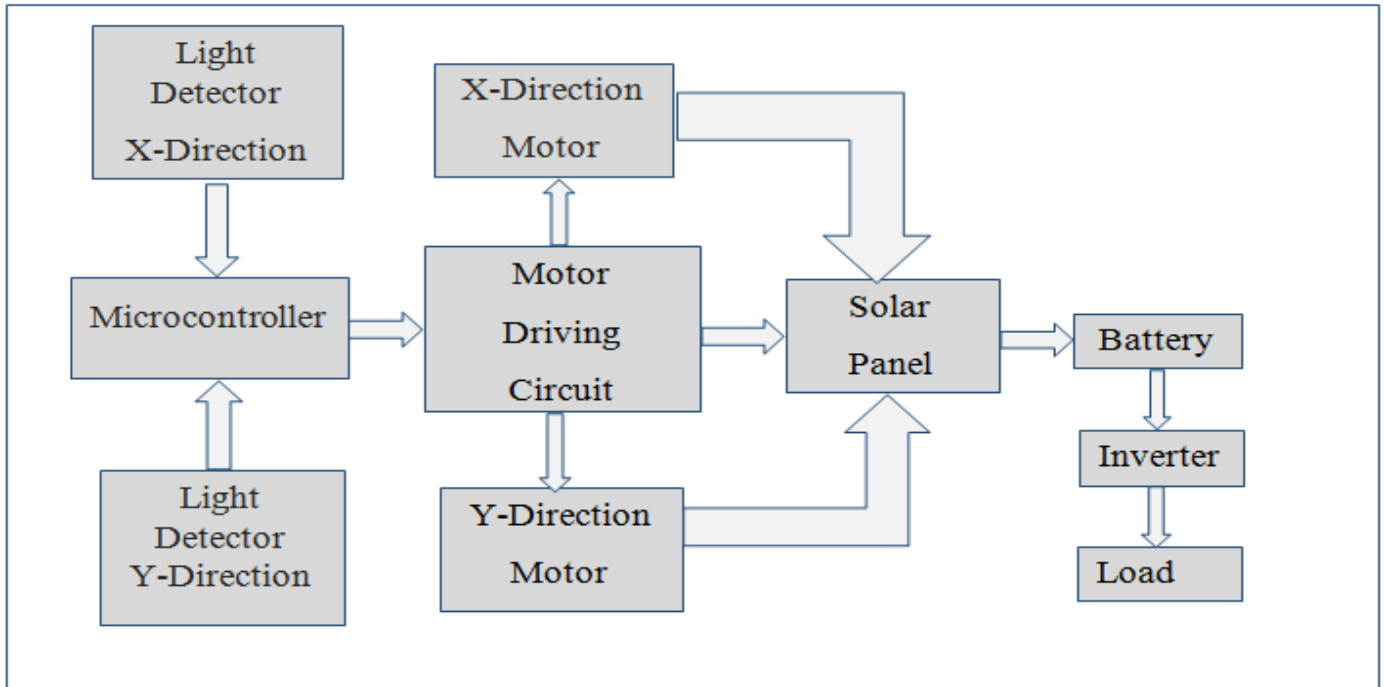

### B. Model of our project

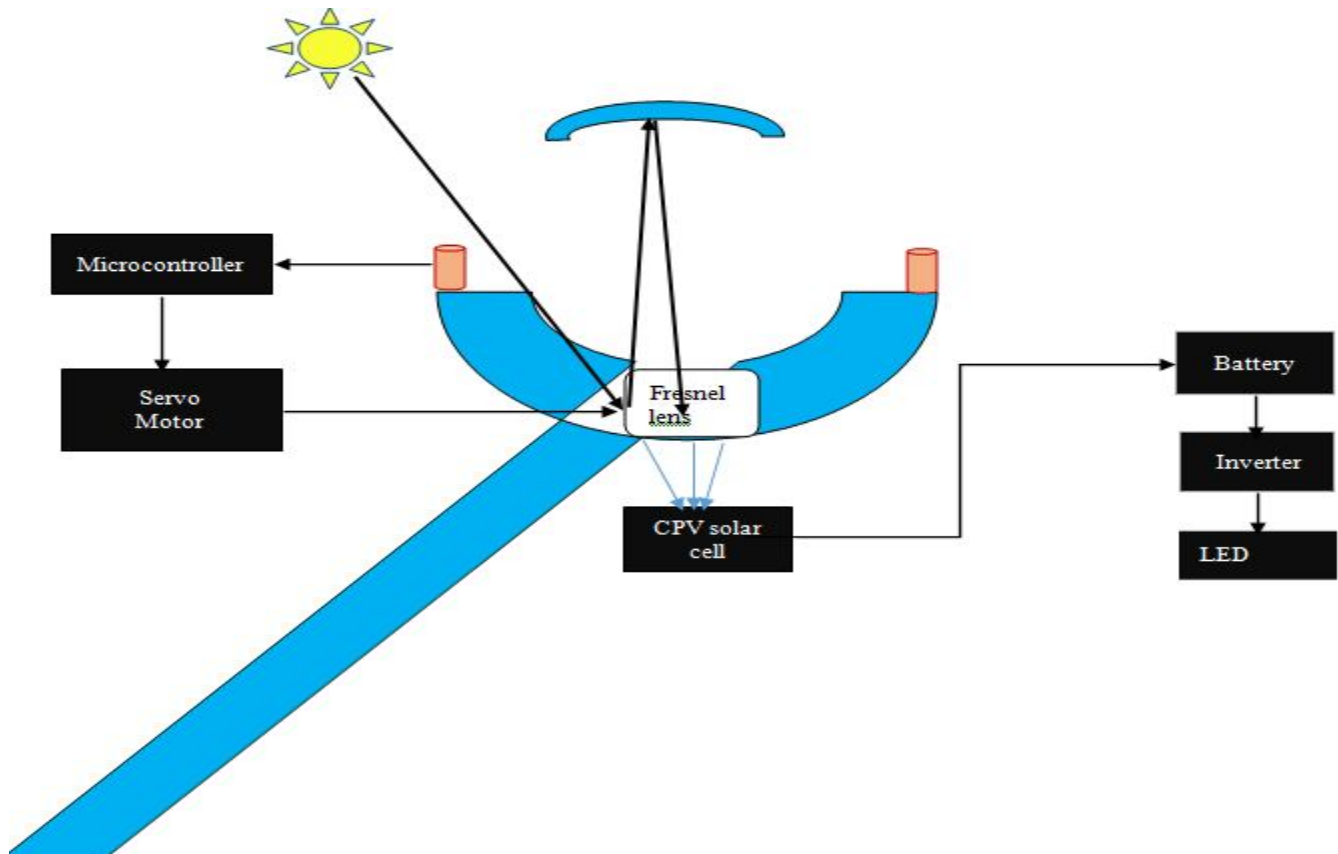

### C. Construction

The basic design of the solar tracking system is parabolic, in which the reflective glass mirror 1 is placed over it which is used to reflect the incident sun radiation and on the top, the reflective mirror 2 is placed which is used to reflect the reflected radiation from the mirror 1. The LDR (Light Dependent Resistor) is placed on the four sides of the parabolic mirror reflector 1. The PIC 18F4550 microcontroller which uses the LDR output and tracks the reflector to the sun's direction by using the DC servo motor. The Fresnel lens is used to concentrate the incident radiation and focuses it into the

Concentrated photovoltaic cell (CPV) and the generated electricity from the CPV is stored in a battery. Since, the charge from solar is DC the inverter is used to convert it into AC. The current generated from the solar can be used to run the load of 12V.

## III. PROJECT DESCRIPTION

### A. Sensing Module:

The photo resistor or LDR is a device whose resistivity is the function of incident electromagnetic radiation. LDR is used to sense the solar radiation from the sun light through which the tracking system is enable

### B. Tracking Module:

The DC servo motor tracks the parabolic dish in a direction parallel to the radiation of the sun, according to the control signal from the PIC microcontroller.

### C. Extraction Module:

In this the radiation is focused into the multi-junction solar cell by using the fresnel lens as a concentrator. The multi-junction cell converts the incident solar energy into electrical energy by photovoltaic principle.

### D. Output Module:

The energy that is extracted is stored in the battery for future use. The energy that is produced can be used to glow an LED light of 10 X 10 feet room.

## IV. SOFTWARE DESCRIPTION

The system is controlled by microcontrollers which act as a main processor of the tracking system. The Micro Pro

for PIC tool is used to communicate with the microcontroller where the required instructions are specified to control the parabolic dish to the direction where the radiation is maximum. The Micro PIC is a real time communication tool with high computational power and has the capability to take dynamic decision at any instant. It is small and reasonably simpler to learn, understand, program and debug. It has the advantage of processor independence i.e. it is independent of the kind of controller or processors used, and is not specific to any particular microprocessor/ microcontroller or any system. When the intensity of the radiation is low, then the control signals are given from the microcontroller to track the dish to the direction where the sunlight is maximum.

## V. FUTURE WORK

The heat that is generated during this process sums to a large amount which is wasted by the process of vaporization. So, we had planned to convert this waste resource into useful one by using the thermal generator. The thermal generator is a one which converts the heat energy directly into an electrical form. By implementing this technique we can further improve the efficiency.

## VI. CONCLUSION

Thus, by the implementation of this tracking system which uses the parabolic dish and concentrated solar cell we can improve the efficiency to a few percent compared to the normal method which uses the single junction cell. Further, we can save the material consumption when the concentrated cells are used and provide a clean environment for the future generation.

## REFERENCES

- [1] Ahad Ali, Eklas Hossain and RizaMuhida Member, IEEE "Efficiency Improvement of Solar Cell Using Compound Parabolic Concentrator and Sun Tracking System" IEEE Electrical Power & Energy Conference, 978-1-4244-2895-3/08/\$25.00 ©2008 IEEE.
- [2] Ahmad FarisDzulkipli, Eklas Hossain, KhairulAzizi Abdul Rahman, and RizaMuhida, "Solar Cell Efficiency Improvement Using Compound Parabolic Concentrator and an Implementation of Sun Tracking System" in 1-4244-2136-7/08/\$20.00 ©2008 IEEE.
- [3] Balasubramanian K and Koyuncu B, "A Microprocessor Controlled Automatic Sun Tracker", in Contributed Paper Manuscript received August 5, 1991, 0098 3063/91 \$01.00 ID 1991 IEEE.

- [4] Hui Yang, Jingfeng Mao, JupingGu, LaiwuLuo, Yinxiang Cao,” A Photovoltaic Generation Heating System Based On Double Parabolic Reflector Focusing and Hybrid Tracking Technology”, in 978-1-4244-8165-1/11/\$26.00 ©2011 IEEE.
- [5] Kassem and Hamad M,” A Microcontroller-Based Multi-Function Solar Tracking System”,978-1-4244-9493-4/11/\$26.00 ©2011 IEEE.
- [6] Michael A. Soderstrand, Peter Chung, Sung Baek Lee, “Mini-Dish Based Hybrid Concentrated Solar Power (CSP) System for Home Use”, 978-1-4799-0066-4/13/\$31.00 ©2013 IEEE.
- [7] Nang KaythiHlaing, LwinLwinOo, “Microcontroller-Based Two-Axis Solar Tracking System”, in 978-0-7695-4043-6/10 \$26.00 © 2010 IEEE.
- [8] Nitesh Malhotri, Priyanjan Sharma,” Solar Tracking System Microcontroller”, in Proceedings of2014 1st International Conference on Non-Conventional Energy (ICONCE 2014), 978-1-4799-3340-2/14/\$31.00 ©2014 IEEE.