

Photovoltaic Maximum Power Tracking with Battery Charging Application using SEPIC Converter

S. Nesa Priya¹, B. Preethi², V. Sangavi³, P. Sharmila Mary⁴

^{1, 2, 3, 4} Department of EEE

^{1, 2, 3, 4} Saranathan College of Engineering, Trichy, Tamilnadu, India

Abstract- The solar energy is a renewable source of energy the output of the Photovoltaic panel has nonlinear I-V characteristics that vary with solar insolation. This paper describes a technique for tracking of the Maximum Power Point (MPPT) of a solar panel and charging a lead acid battery. An MPPT (Maximum Power Point Tracking) charger plays an important role in photovoltaic Systems because it maximizes the power output of the photovoltaic panel array for different levels of irradiation and panel temperature leading to more energy harvested .A SEPIC converter is used where the duty cycle is varied to attain the desired MPPT level. An algorithm to obtain the MPP is built using ATmega328 microcontroller and tested to charges a 14 Ah lead acid battery with a 40W solar panel.

Keywords- Photovoltaic, Insolation, SEPIC, MPPT.

I. INTRODUCTION

The output of the solar panel depends upon the light radiation on the solar panel. The maximum power is extracted from the panel by using constant voltage MPPT algorithm by varying the duty cycle of the converter as shown in fig 1.1. That PV array output power is used directly to the SEPIC (dc-dc converter).The SEPIC converter converts topology and provides a regulated output voltage that varies above or below the input voltage .

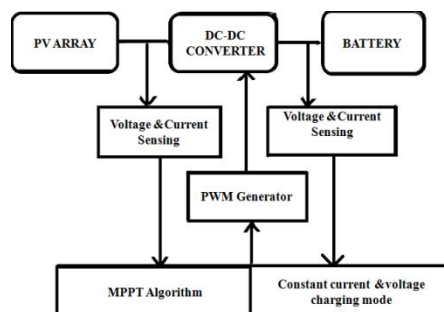

Figure 1.1 Block diagram of the entire process

The load controller (ATMEGA 328) is used to connect or disconnect the battery from the panel depending upon the terminal voltage of the panel and the current drawn by the battery .The resulting system has high efficiency, low cost and easy implementation

II. MAXIMUM POWER POINT TRACKING

MPPT-Maximum Power Point Tracking is to charge battery in an more efficient manner, The PV array is operated at a point where the PV output power is maximum. The output power of the PV array changes with the change in voltage across it. To extract maximum power from the PV array, a DC to DC converter is used between the PV array and the battery. The duty cycle of the DC to DC converter is controlled to impose optimum voltage across the PV array which corresponds to maximum power point. The charge controller looks at the output of the panels, and compares it to the battery voltage. It then figures out what is the best power that the panel can put out to charge the battery. It takes this and converts it to best voltage to get maximum AMPS into the battery

2.1. Solar Panel Characteristic

Solar cells convert the electromagnetic radiation directly into electrical current. Series and/or parallel connection are made between these cells in order to achieve desired output voltage and current for the solar panel. Each solar panel is designed to produce a certain power (voltage, current) under specific conditions. Typically, the solar panel manufacturers provide the following electrical characteristics as shown in table 2.1.1

(Table 2.1.1): Electrical characteristics of single crystal silicon photovoltaic module with 40 w maximum Power.

Electrical characteristics	
Type of cell	Monocrystalline – sharp silicon solar cells
Open circuit voltage	21.37 V
Short circuit current	2.50 A
Maximum power voltage	17.18 V
Maximum power current	2.33 A

These electrical characteristics are given for the standard test conditions (STC) but the maximum power point of a solar panel is changing in accordance with changes in the solar irradiation intensity, angle and panel temperature.

The current and power versus voltage characteristics of this 40w panel under irradiation of 850 Lux is shown in figures 2.1.1 and fig 2.1.2 respectively

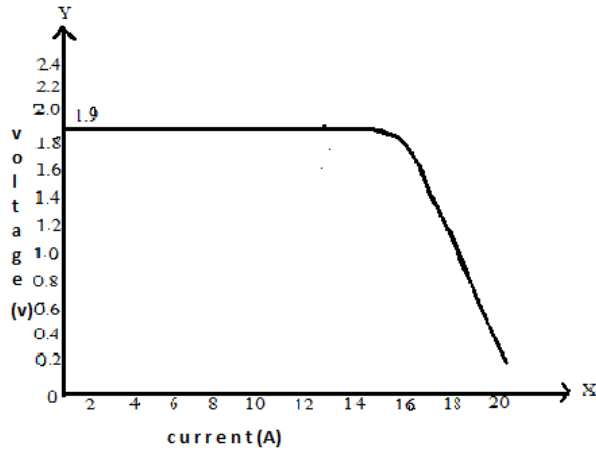

Fig. 2.1.1 Voltage V, current characteristic at an irradiation of 850lux

Fig. 2.1.1 illustrates the operating characteristics of the solar panel under 850 lux solar irradiation level. It consists of two regions: one is the current source region, and the other one is the voltage source region. In the voltage source region, the internal impedance of the panel is low. That region is the right side of the current-voltage curve. The current source region, in which the internal impedance of the panel is high, is at the left side of the current-voltage curve. The maximum power point of the panel is located at the knee of the current-voltage curve.

According to the maximum power transfer theory, the power delivered to the load is maximum when the source internal impedance matches the load impedance. Thus, the impedance seen from the converter input side needs to match the internal impedance of the solar panel. If the system operates on the voltage source region (namely low impedance region) of panel characteristic curve, The panel terminal voltage will collapse. It can be observed that curve (fig 2.1.2) have a maximum power point, which is the optimal point for the efficient use of the panel. This point depends on the values of solar irradiation intensity and working temperature.

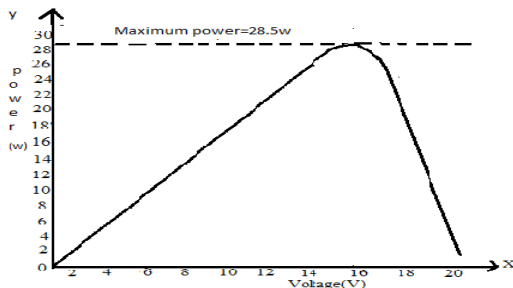

Fig. 2.1.2 power vs voltage curve for irradiation of 850 lux

Thus, a DC/DC converter will be used to match the source internal impedance with the load impedance achieving the MPP

2.2. Constant Voltage MPPT Method

The constant voltage method is based on the observation from I-V curves that the ratio of the array’s maximum power voltage V_{mp} to its open-circuit voltage V_{oc} is approximately constant:

$$V_{mp}/V_{oc}=K < 1 \dots\dots \text{equation}(2.2.1)$$

The solar array is temporarily isolated from the MPPT and a V_{oc} measurement is taken. Next, the MPPT calculates the correct operating point using equation 2.2.1 and the preset value of K , and adjusts the array’s voltage until the calculated V_{mp} is reached. This operation is repeated periodically to track the position of the MPP. The literature reports success with K values ranging from 73 to 80%., Constant voltage control is normally favored because of the relative ease of measuring voltages, and because open-circuiting the array is simple to accomplish, but it is not practically possible to short-circuit the array and still make a current measurement. The constant voltage method is implemented using the flowchart shown in Fig 2.2.1.

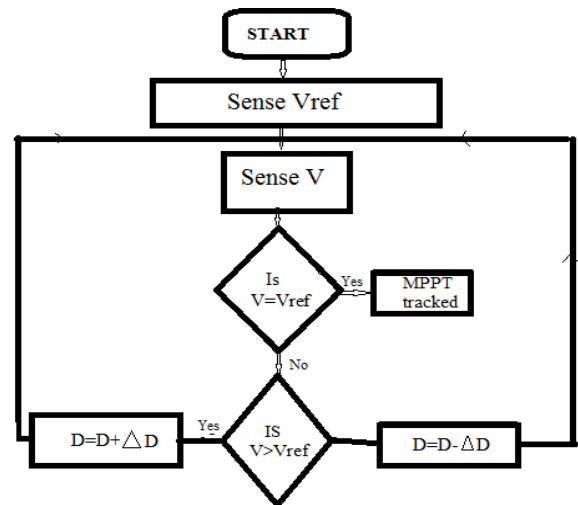

Figure 2.2.1 flowchart of constant voltage MPPT algorithm

2.3 Implementation

This method is based on the observation that MPP voltage (V_{mp}) has almost a linear relation with open-circuit voltage (V_{oc}) of the PV panel.

$$V_{mp} = K * V_{oc} \dots\dots \text{equ}(2.3.1)$$

where K called the voltage factor is equal to 0.71 for the silicon panel and has different values for different solar panels ranging from 71% to 86%.

The PV panel is locked at the reference voltage given by equation 2.3.1. The open-circuit voltage required to determine the MPP voltage is measured by disconnecting load from the PV panel after regular intervals. The measured value of V_{oc} and K are stored and used for determination of the PV panel voltage V. To operate the panel at MPP, the actual PV panel voltage V is compared with the reference voltage V_{ref} , which corresponds to the MPP voltage V_{mp} . The error signal is processed to make $V = V_{ref}$. The error signal is used to change the duty cycle of a dc-dc converter, interfaced between the PV panel and the load, so as to make the PV panel voltage equal to the MPP voltage.

III. SEPIC CONVERTER

3.1 MOSFET DRIVER CIRCUIT (TLP 250)

It is used to amplify the gate pulse voltage to MOSFET. Threshold needs by pushpull amplification. The schematic of TLP250 is shown below. It should be noted that the V_{cc} must be between 12V to 24 V which is the operating range of the driver. A capacitor is connected across the supply pins to filter the ripples in the supply. Pin 2 and 3 forms the input. Pin 6 is output which is connected to the gate of the MOSFET.

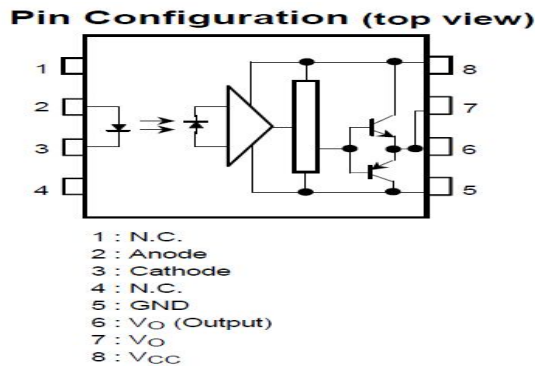

3.2 Principle

The Single Ended Primary-Inductance Converter is a DC to DC converter .It provides a positive regulated output voltage from an input voltage that varies from above to below the output voltage .The SEPIC converter is difficult to understand and requires two inductors , power supply is quite large.

3.3 OPERATION OF SEPIC

SEPIC converter, consisting of a coupling capacitor (C_p), output capacitor (C_{out}), inductors L_1 and L_2 , power FET Q_1 , diode D_1 . To understand the voltages at the various circuit nodes ,it is important to analyze the circuit at DC when S is off and not switching. During steady state continuous conduction mode, Pulse-Width-Modulation (PWM) operation and neglecting ripple voltage, capacitor C_p is charged to the input voltage V_{in} . When S is off the voltage across L_1 must be V_{out} . Since C_1 is charged to V_{in} , the voltage across S, When S is off is $V_{in}+V_{out}$, so the voltage across L_1 is V_{out} . With S1 open current through L_1 (blue) and current through L_2 (red).

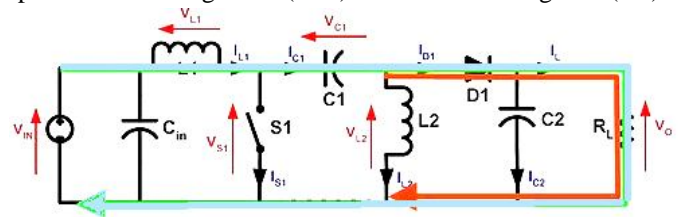

Figure 3.1 Operation of SEPIC when switch is OFF

When S is on, capacitor C_1 , charged to V_{in} , is connected in parallel with L_1 , so the voltage across L_1 is $-V_{in}$. And energy is being stored in L_1 from the input and in L_1 from C_p . When S turns off , L_1 's current continues to flow through C_1 and D_1 , and into C_2 and the load. Both C_2 and C_1 get recharged so that they can provide the load current and charge L_1 respectively, when Q_1 turns back on. With S1 closed current increases through L_1 (blue) and C_1 discharges increasing current in L_2 (red)

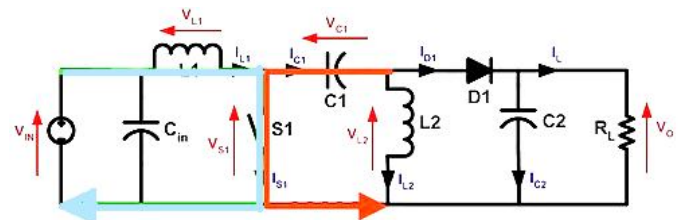

Figure 3.2 Operation of SEPIC when switch is ON

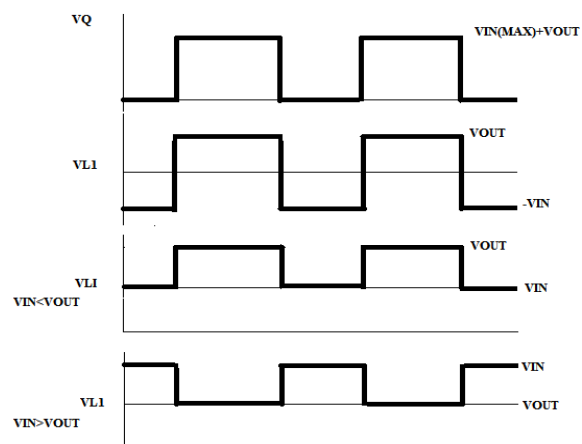

Figure 3.3 SEPIC Component voltages during CCM

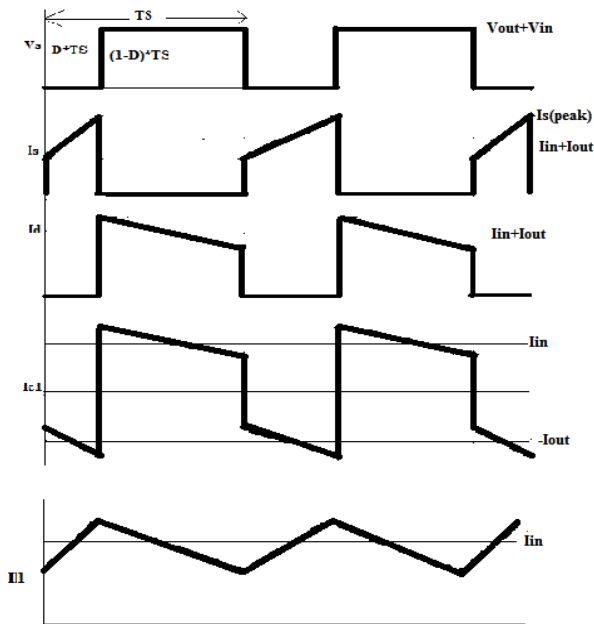

Figure 3.4 SEPIC Component current during CCM

IV. BATTERY CHARGING STAGES

The lead acid battery uses the Constant Current Constant (CC/CV) charge method. A regulated current raises the terminal voltage until the upper charge voltage limit is reached, at which point the current drops due to saturation. With higher charge currents and multi-stage charge methods, the charge time can be reduced to 8-10 hours.

$$C_{RATE} = (\text{capacity of battery in Ah}) / (\text{Total charging hours})$$

$$= 14/10 = 1.4 \text{ A/hr.}$$

Lead acid batteries should be charged in three stages, which are [1] constant-current charge, [2] topping charge and [3] float charge

4.1 Constant Current Stage

The constant current stage applies bulk of the charge. It takes half of the total charging time in our case it takes 5-6 hours. The voltage applied is increased till the current reaches the saturation point. The battery is charged to 70 percent during this stage.

4.2 Topping Charge Stage

The switch from Stage 1 to 2 occurs seamlessly and happens when the battery reaches the set voltage limit. The current begins to drop as the battery starts to saturate; full charge is reached when the current decreases to 3 to 5 percent of the Ah rating. when the battery reaches its saturation limit. The current decreases on further increase in the voltage this

implies that there is no potential difference between the applied voltage and the battery voltage and the battery is fully charged in this stage and the voltage remains constant during this stage. The charging time is around 7 to 10 hours.

The topping charge is essential for the well being of the battery. If continually deprived, the battery will eventually lose the ability to accept a full charge and the performance will decrease due to sulfation. The float charge in the third stage maintains the battery at full charge. Figure 4.1 illustrates these three stages.

4.3 Float Charge Stage

The float charge in the third stage maintains the battery at full charge. The voltage is lowered to a float charge level.

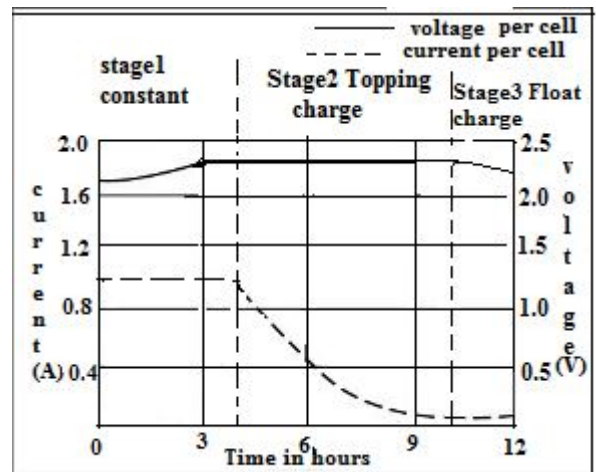

Figure 4.1 Battery Charging Stages

V. CONCLUSION

For the Illumination of 850 Lux the maximum power of 29.8634 Watts is obtained by varying the duty cycle to 44%.for the input voltage of 17.18 V

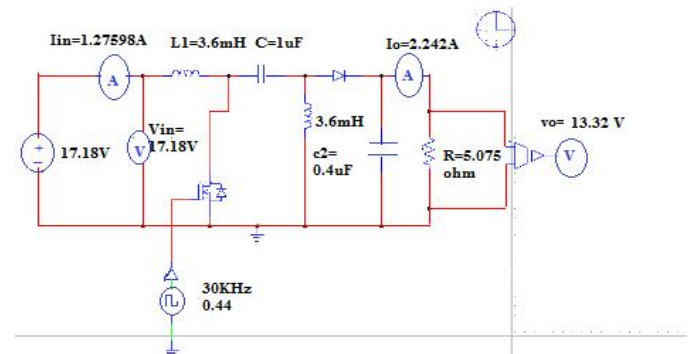
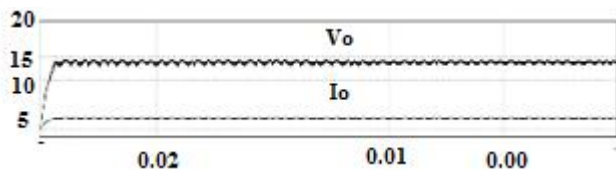

Figure 5 1 SEPIC converter output with duty cycle Of 44% where MPPT is tracked in PSIM simulation environment

The circuit diagram(fig 5.1) is the SEPIC converter design for the Maximum power of 40W but power obtained was only 30W due to poor insolation. The output current from the SEPIC converter is used to charge the battery for a period of 6 hours using timer. Then the battery is charged using constant voltage output of the converter for 4 hours. Then the input voltage to battery is reduced to float charge level to keep battery at full charge. The waveforms of the output voltage and output current is shown below,

It is difficult to track the constant voltage from Panel by the same time we have to charge the battery using constant current algorithm. A comprise is made to charge the battery.

Output Voltage V_o and Output current I_o



Input Voltage V_{in} and Input current I_{in}



LEGEND

Time From	1.688000e-006
Time To	9.999333e-002
I_o	2.197367e+000
V_o	1.3348763e+001
I_{in}	1.7336270e+000
V_{in}	1.71700080e+001

ACKNOWLEDGMENT

The experiment work for this paper was done at Saranathan College Of Engineering.

REFERENCES

[1] Ja-Kyung Koo "Controller Design for Battery Energy Storage System Using Linearised Battery Model",2013 International Conference On connected vehicles and Expo(ICCVE).

[2] DanijelPavkovic,Member, IEEE, Michael Lobrovic, Mario Hrgetic, Ante Komljenovic,and Viktor Smetko "Battery Current and Voltage Control System Design with Charging Application", IEEE Conference on Control Applications(CCA) Part of 2014 IEEE Multi-Conference on Systems and Control,October 8-10,2014.

[3] Trishaw Efram L. and Patrick Chapman L. (2007), 'Comparison of Photovoltaic Array Maximum Power Point Tracking techniques', IEEE Transactions on energy Conversion , Vol 22, pp.439-449.

[4] W. Xiao, N. Ozog, and W. G. Dunford, "Topology Study of Photovoltaic Interface for Maximum Power Point Tracking," IEEE Transactions on Industrial Electronics 54, no. 3 (June 2007): 1696- 1704.

[5] E. Koutroulis, K. Kalaitzakis, and N. C. Voulgaris, "Development of a Microcontroller-Based Photovoltaic Maximum Power Point Tracking Control System", IEEE Transaction on Power Electronics, January 2001 Volume. 16, Issue. 1

[6] M. Veerachary, T. Senjyu, and K. Uezato, "Voltage-based maximum power point tracking control of PV system", IEEE Transactions on Aerospace and Electronic Systems, Jan 2002 Volume: 38, Issue: 1 on page(s): 262-270 [4] Yan Hong Lim, and D.C. Hamill, "Simple maximum power point tracker for photovoltaic arrays", in IET Electronics Letters, May 2000 Volume: 36, Issue: 11 On pages: 997- 999