

# Smart Infinity-Run Hybrid Rider

Prof. R. K. Sarawale<sup>1</sup>, Bhushan Lohar<sup>2</sup>, Shweta Sahu<sup>3</sup>, Sudhanshu Shukla<sup>4</sup>

<sup>1, 2, 3, 4</sup> Department of E&TC

<sup>1, 2, 3, 4</sup> Imperial College of Engineering and Research, Wagholi, Pune

**Abstract-** *Global warming is a major concern all around and to save our Earth, there are several policies, promises and pledges. With the ever increasing emission of greenhouse gases, there is an increased fear of environment pollution at every step. With modern technology and innovation, transportation and communication have undergone a paradigm shift.*

*Along with this, we are also experiencing the negative effects of industrialization in the form of global warming. Under these circumstances, when there are traffic jams, when you need to run an errand at an odd hour of the day, when you need to go to workplace quickly, you stumble and fumble as there are so many vehicles emitting soot and CO<sub>2</sub> polluting the air incessantly. With increased number of fossil-fuel dependent vehicles, they not only add to greater level of pollution but are also leading to depletion of fuel resource. It is here that automobile companies felt the need to innovate motorized vehicle that will get battery operated and will not be depending on fossil fuels. This led to expansion of eco-friendly initiatives and many automobile manufacturing companies invested in research and development to bring forth electric bikes that will help people save a few bucks by reducing consumption of already spiraling fuel price, besides fighting global warming. Most electric bikes are emission-free bikes of the company's manufacturing them in these days of global warming. These electric bikes will not make pollution worse and that makes e bikes environmentally safe vehicle. It can be charged with the help of inverter and generator too. It also makes no noise while under operation. The best part of electric vehicles is that they can be run with no registration and license.*

**Keywords-** Solar System, GSM Module, GPS Module, Relay, Dynamo.

## I. INTRODUCTION

One of the major problems that we face on day to day life is Energy Crisis. Our project is one of the solutions for energy crisis. The system we implemented is a hybrid electric bike. The project has a number of benefits to all the team members as well as external benefits through increasing awareness of alternative transportation modes. Despite the environmental friendliness of the project or the projected benefits of more people relying on non-polluting modes of

transport, the main reason we selected the project was for the level of interaction between us, the engineers, and our project. Designing a transportation vehicle requires consideration of mechanical objectives, electrical objectives, safety criteria, comfort, user friendliness as well as an array of other objectives which may conflict under various circumstances. We hoped that through navigating our way through this vast set of criteria the satisfaction of completing the project would be much greater than other projects we could have selected.

## II. LITERATURE SURVEY

**Literature study into health effects:** It is known that regular cycling (commuting) reduces the risks of various chronic diseases and positively affects some risk factors for cardiovascular diseases. On the basis of the existing literature it is not yet possible to state whether these health effects will also be achieved by using electric bicycles. Two exploratory studies did demonstrate that electric cycling is likely to be sufficiently intensive to yield fitness and health benefits. Possible health benefits as in habitual commuting on conventional bicycles might therefore also occur when cycling electrically. On the basis of the existing literature it is also not possible to make pronouncements on the reasons why electric bikes are used.

**Market research** (Reference 3, Year: 2012): The increased sensibility for environmental problems and the growth of oil price brought scientist and companies to invest significant resources on exploiting different energy sources and means of transport with more than one source of power. Particularly automotive field dragged an increasing interest in vehicle electrification. Moreover in urban area environmental and traffic issues lead to enforce strict normative and to create new paradigm for urban mobility (e.g. car and bike sharing), in order to decrease pollutant emissions. In this urban context, Light Electric Vehicles (LEVs) are receiving great attention, particularly Electrically Power.

**Mobility effects** (Reference 1, year 2010): This paper is originated after studying the electric bikes and electric cars manufactured by the small scale industries in India. The frequent problems faced by the manufacturers are effective speed control of the system, the provision to recharge the battery while running and the efficiency of the system in terms

of mileage, torque and load handling capacity. With this as a base, this project was started to solve the above real time problems existing in electric cars and in electric bikes.

**Environmental effects** (Reference 2, Year: 2013): Energy prices and environmental considerations have increased the interest on Light Electric Vehicle (LEV). Strict regulations and new paradigms for urban mobility (e.g. bike and car sharing) have been developed in urban areas in order to tackle traffic issues and pollution. In this urban context, Electrically Power Assisted Cycles (EPACs) are receiving a great deal of attention. EPACs have great potential to improve urban mobility. EPACs reduce the physical fatigue associated with cycling and thus enlarge the use basin. However, as all electric vehicles, they still suffer from some disadvantages limited range, increased weight compared to a normal bicycle and long recharging time. This work further develops the concept of the novel full hybrid electric bike (HEB), already presented in, by developing a charge sustaining strategy. The HEB is configured as a parallel hybrid vehicle and its main characteristics are:

- Self-sustenance (the bike is grid-independent and does not need to be recharged);
- Small added weight (the HEB needs a smaller battery pack);
- The HEB helps cyclists during power peaks and is recharged by pedalling during cruising.

This work stems from previous research. In the rationale has been presented and validated on a cycling track following a specific protocol, *i.e.* speed profile, showing a reduction of 30% of the consumed oxygen (an *indication* of metabolic efficiency). In this work a casual charge sustaining strategy that does not require *a priori* knowledge of the speed profile is designed and validated. The effects of the proposed strategy are discussed using an causal charge sustaining strategy as benchmark and available results on the load-dependent efficiency of cyclists.

### III. BLOCK DIAGRAM OF THE SYSTEM

Basic Idea of this electrical bike is that this bike will operate on two batteries. One battery will be charged when second one is discharging and vice versa. Switching of these batteries will be automatic with the use of microcontroller and relays. Voltage sensors will be used to find charging level of battery and to take decision based on that.

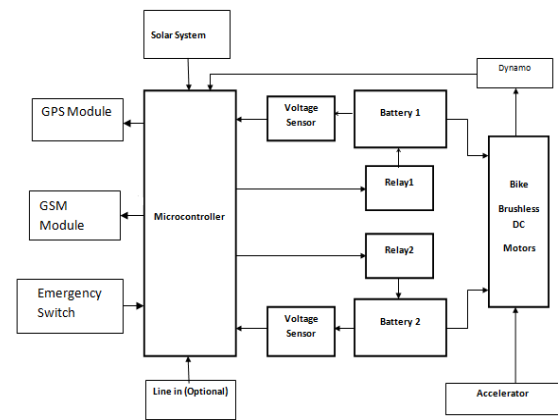

Figure 1 : Block Diagram of Hybrid Rider

Charging of both the batteries through dynamo, also we are adopting solar system to boost the charging of the batteries and the optional external 'line in' for charging the batteries if main charging system fails. If one of the batteries fails then it will alert us and the working battery will automatically charging through 'solar system' or 'line in' when bike will be steady. Accelerators are used for accelerating the bike.

The GPS module is used to automatically send our exact location to our friends or relatives if accident occurs on unknown area by pressing emergency switch.

### IV. SOFTWARE DEVELOPMENT

Proteus 8 is a single application with many service modules offering different functionality (schematic capture, PCB layout, etc.). The wrapper that enables all of the various tools to communicate with each other consists of three main parts.

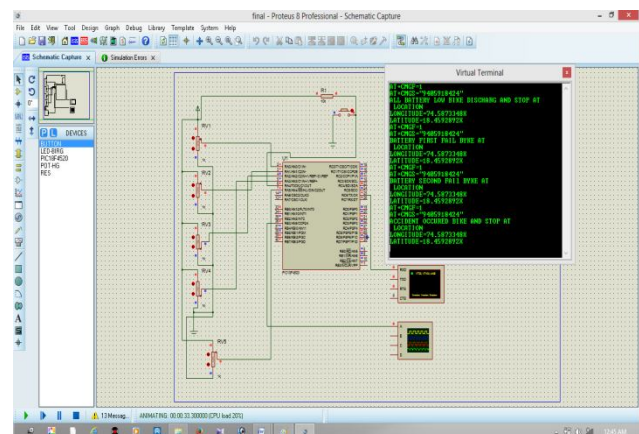

Figure 2 : Simulation Result

## V. RESULTS

Sr. no	Time(Hrs)	Charging Level (V)	Discharging Level (V)
1	1	2	10.3
2	2	5	7.8
3	3	8	4.4
4	4	12	2.7

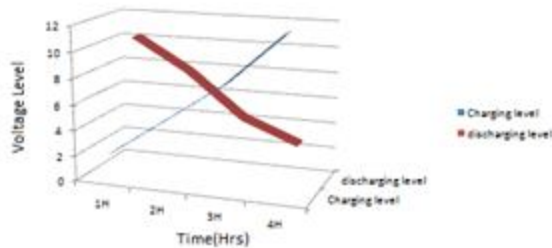
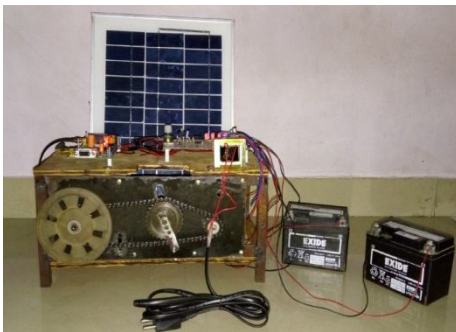

Figure 3: Graph of System Analysis

As shown in Figure charging of batteries is up to 12V. Both charging and discharging are simultaneous processes. In first Hr battery 1 charges to 2V. Along with this battery 2 discharges to 10.8v. During operation of system same process is carried out. The above graph indicate overall system analysis with variation of parameters.

## VI. DEVELOPED SYSTEM



## VII. ACKNOWLEDGEMENT

It is a great pleasure for us to present a project “Smart Infinity-Run Hybrid Rider” where guidance plays an invaluable key and provides concrete platform for completion of the project.

The hard work and perseverance of our mentor will always be embedded in our memory. Project execution would

not have been possible for us without the continued assistance of certain people. We take this opportunity to express our deepest gratitude for all the heartfelt assistance rendered.

We thank Prof. R.K.Sarawale our project guide who was responsible for coordinating all efforts and sincerely grateful to him for helping to achieve high standards of performance.

We are very grateful to Prof. P.R Badadapure HOD of ICOER, Wagholi for making available all the facilities required for the successful completion of the project.

## VIII. CONCLUSION

The hybrid bike can be powered by dual source such as dynamo and solar system. Compared to ordinary bikes this hybrid bike is more efficient and economic. This hybrid bike will be a new innovation in automotive area, it is more eco-friendly as it does not produce the severe pollution like the traditional bikes. The hybrid bike is a better solution for hiking fuel cost day to day.

## REFERENCES

- [1] "Hybrid electric bike with three speed transmission system an energy efficient bike for next generation" Nagendran, R. ; Kumar, K.S. , Computer Engineering and Technology (ICCET), 2010 2nd International Conference on Volume: 7 DOI: 10.1109/ICCET.2010.5485320 Publication Year: 2010 , Page(s): V7-133 - V7-135
- [2] "Self-sustaining strategy for a hybrid electric bike" Spagnol, P. ; Corno, M. ; Mura, R. ; Savaresi, S.M. American Control Conference (ACC), 2013 DOI:10.1109/ACC.2013.6580369 Publication Year: 2013 , Page(s): 3479 – 3484
- [3] "A full hybrid electric bike: How to increase human efficiency" Spagnol, P. ; Alli, G. ; Spelta, C. ; Lisanti, P. ; Todeschini, F. ; Savaresi, S.M. ; Morelli, A. American Control Conference (ACC), 2012 DOI: 10.1109/ACC.2012.6314871 Publication Year: 2012 , Page(s): 2761 – 2766.
- [4] “Easy rider” Schneider, D. Spectrum, IEEE Volume: 46, Issue: 9 DOI: 10.1109/MPESC.2009.5210037 Publication Year: 2009, Page(s):26-27