

Bank Locker Security System Using Gsm

Mule Sonali¹, Sarane Gurudevi², Shinde Shalaka³, More Vaishali⁴, Assistant Prof. Ghodake Y.S⁵

^{1, 2, 3, 4, 5} Department of Electronics and Telecommunication

^{1, 2, 3, 4, 5} Karmayogi Engineering College Shelve, Pandharpur

Abstract- In most of the offices and banks lockers are used to secure valuable documents or any valuable thing so Locker security is becoming an important issue in recent days. Nowadays there is demand for more efficient security systems to avoid access of unauthorized persons. This paper will show the design and construction of GSM based bank locker security system. Most of resent system a unique password is set to open locker, which is only known to authorize person. The user uses this password again and again so somebody can hack that password and also if password leaks then it affect security of system. The most of locker systems are based on only mechanical key operations; if key is misplaced or stolen then again it is difficult to maintain security of that locker.

Keywords- Lcd, GSM Module, Microcontroller, Keypad, DC Motor

I. INTRODUCTION

In most of the offices and banks lockers are used to secure valuable documents or any valuable thing so Locker security is becoming an important issue in recent days. Nowadays there is demand for more efficient security systems to avoid access of unauthorized persons. In resent system a unique password is set to open locker, which is only known to authorize person. The user uses this password again and again so somebody can hack that password and also if password leaks then it affect security of system. The most of locker systems are based on only mechanical key operations; if key is misplaced or stolen then again it is difficult to maintain security of that locker. The GSM technology is used to send the password to the authorized person's mobile phone via SMS. The tag password request sent to authorized person, if the person send the password to the microcontroller, which will verify the passwords entered by the key board and received from authenticated mobile phone. If these two passwords are matched the locker will be opened otherwise it will be remain in locked position. Now a recent days the locker security is very important problem of employed. In security systems in various sectors such as banks, offices, houses etc. are mechanical Key method or single password method. These traditional methods are not fully secure due to robbery of keys or knowledge of password. The proposed technique is implemented for bank locker security. For long, lockers have been the first choice to safeguard valuables for most people and they continue to be the safest option. Bank locker security is most important for the safety of the

valuables. Present day bank security systems deploy mechanical key method wherein a user possesses one of the two keys whereas an authorized bank official possesses the other.

The user has to tag the bank official along with him/her to access his/her locker. The user key along with the bank official's key can provide access to the user. The conventional method has many drawbacks such as –

- Both the bank employees must have to present with the keys to open the locker.
- There is possibility of losing the key which makes the system insecure. The system is unable to match with today fast pacing digital world.
- The keys can be duplicated

Due to the above mentioned drawbacks, a need has arose to develop a more secure, reliable and faster technique which would overcome the drawbacks and provide full security to the customer. . Hence, we have proposed a more secure system which employs SMS based and GSM technologies. The proposed technique activates, authenticates and validates the user and then unlocks the locker. We have tried to solve the above problem through our project by bank locker security using GSM.

II. METHODOLOGY OF BANK LOCKER SECURITY SYSTEM USING GSM

Three parts have included under this topic completed this study. Design architecture is the main function for the proposed design. While, the hardware specification will detail out the components involved in this design from the sensor components until the controller selection. Software development based on the proposed design will be detail out in software part where the flow of the system operation will be detailed out elaborated.

A. DESIGN ARCHITECTURE

The system development is start with the design architecture of the proposed design. Transparent block diagram has been used to outline the proposed design as shown in Figure 1. We use Keypad, GSM modem, PIC16F877A, PIR sensor, DC motor, LCD display, Buzzer.

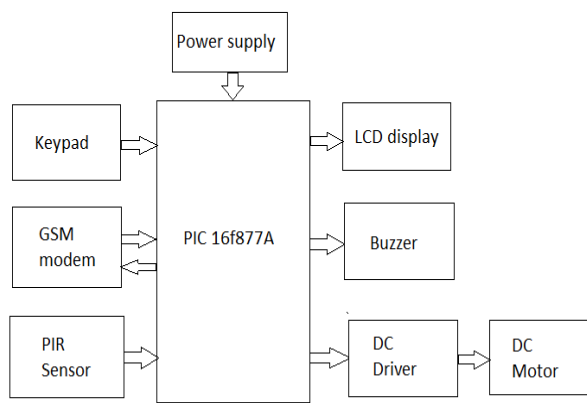

Fig.1. Block Diagram

The Main concept behind this project is of a bank locker latch opening using two passwords which are entered through SMS and keypad. Each bank locker will have a GSM modem connected to it. When owner of the bank locker wants to open the locker then he/she has to sends a password through SMS. Then microcontroller connected to GSM modem reads the contents of password. If contents are correct then it will enable the keypad to enter second password. Now user has to enter second password using Keypad. If second password is correct then system allows user to access locker. We have provided a DC motor which will operate when both passwords are correct. We use Buzzer will be turned on if any one of two passwords is wrong. Microcontroller sends SMS to user for wrong password as well as for correct password. We have also provided a PIR sensor in this project. PIR sensor will be triggered when some person is standing in front of Locker. Then system will send SMS to the owner. This is low warning message as, "Some person is standing in front of your bank locker". PIR sensor will be turned off when user send first password through SMS.

B. HARDWARE SPECIFICATION

In hardware specification, the components for the proposed system have been classified based on the components group; in hardware system there are total SEVEN parts.

1. KEYPAD,
2. GSM modem,
3. PIC 16F877A,
4. PIR SENSOR,
5. DC MOTOR,
6. LCD DISPLAY,
7. BUZZER.

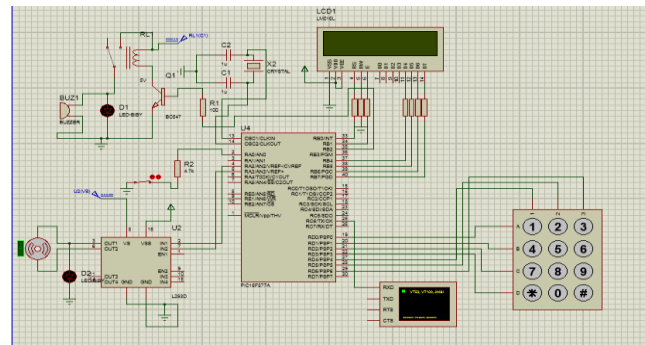

Fig.2. complete schematic diagram for the proposed design.

Fig. 2 shows the overall system schematic circuit that has been designed in this paper to Bank locker security system using PIC microcontroller and GSM module.

C. SOFTWARE DEVELOPMENT

The PIC microcontroller required a program to operate and execute the process associated with the proposed design. Fig.3 shows the flow chart of our system.

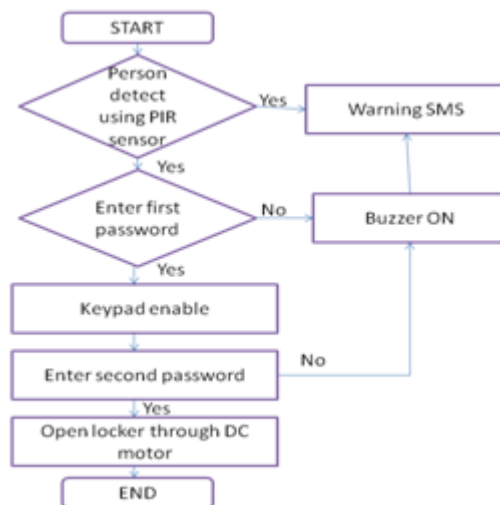

Fig.3 Flow Chart

III. RESULT AND DISSCUSION

This system tested on the latest technology available in Smartphone which gives a proper result. This system is easy to use and very simple. The model can be installed with a economical cost. The GSM technology gives a good response after received a message of particular action from microcontroller. SMS received time to Bank locker owner is basically depend on the signal strength range that you have got through mobile tower. We have developed and tested the model using C language further the same model can be enhanced with the help of some high end language and which would be more portable.Fig.4 shows prototype of bank locker system.



Fig.4 Prototype of Bank Locker Security System



Fig.5 receiving message facility

IV. CONCLUSION

The GSM based Bank locker security system has been designed and tested with the mobile network. The user can get alerts anywhere through the GSM technology thus making the system location independent. A flexible way to control and explore the services of the mobile, AT commands is used in the system. The communication of bank locker security is only through the SMS which has been tested with the mobile networks and is working on authenticated mobile number.

REFERENCES

- [1] Bhavesh chaudhari “smart locker security system ”IEEE international journal 2014.
- [2] Shweta S. joshi “bank locker security system based on GSM and random password” international journal of advanced research.
- [3] Muhammad ali mazidi janice gillispie mazidi rolin d.Mckinlay.