

Voltage Sag Mitigation by PB-AVQR

Mr. Pramod V. Chaudhary¹, Prof. Alka Thakur²

^{1,2} Department of Electrical Engineering

¹ SSSUTMS, Bhopal, Madhya Pradesh, India.

² HOD, SSSUTMS, Bhopal, Madhya Pradesh, India.

Abstract- Voltage sags have always been a huge threat to sensitive industrial and commercial electrical consumers, and deep sags with long duration time are usually more intolerable. In this paper, a new topology of series-connected compensator is presented to mitigate long duration deep sags, and the compensation ability is highly improved with a unique shunt converter structure acting as a parasitic boost circuit that has been theoretically analyzed. Additionally, the proposed active voltage quality regulator is a cost-effective solution for long duration sags that are lower than 50% of the nominal voltage as it is transformer less compared with the traditional dynamic voltage restorer. High operation efficiency is ensured by applying the dc-link voltage adaptive control method. Analysis, along with simulation and experimental results, is presented to verify the feasibility and effectiveness of the proposed topology

Keywords- Dynamic Sag Correction, Long Duration Deep Sag, Parasitic Boost Circuit, Voltage sag.

I. INTRODUCTION

The requirement of the industries and critical loads were possible only because the modern industries were able to find innovative technologies that have successfully become technological developments. There are variety of voltage fluctuations that cause problems including momentarily disturbances, harmonic distortion, voltage sag, surges and spikes. Voltage sag are most significant power quality problem facing industrial customers today. Internal source and external sources are mainly two sources of voltage sag. Storms are most common external source of sag. Start up large loads, animals, ice loading these are other sources of external sag. Grounding of wiring problems and start up of large loads are the internal sources of sag.

Following are some electrical conditions that affect both side utility and customer

1. Phase Outage
2. Voltage sags
3. Voltage Unbalance
4. Disturbances due to capacitor switching, Non-linear loads
5. Presence of harmonics

Due to disturbances there is burn out of motors, unnecessary downtime, increased maintenance cost and burning of core material in industries take place mostly in plastic industries, paper mill and semiconductor plants. There are two types of devices in order to solve above problems as given below.

- a) Utility based solutions
- b) Customer based solutions

The example of those two type solutions are custom power devices and FACT devices that are based on solid state power electronic components. Custom power devices are controlled by customers whereas FACT devices are controlled by utility itself and installed at the customer premises. In order to find cost effective solution for mitigating deep voltage sag obtained novel topology called transformer less active voltage quality regulator with parasitic boost circuits. It is able to eliminate long duration deep sag without increasing cost, volume and complexity. In this paper Principle of working of proposed topology presented along with parasitic boost model and theoretical analysis is provided

II. TOPOLOGY AND PRINCIPLE

As shown in Fig. 1, the PB-AVQR topology is mainly consists of five parts, including a static bypass switch (VT1, VT2), a half-bridge inverter (V1, V2), a shunt converter (VT3, VT4), a storage module (C1, C2), and a low-pass filter (Lf, Cf). The operating mode and applied control strategies are similar to DySC. Under normal operating conditions, the static bypass switch is controlled to switch on and the normal grid voltage is delivered directly to the load side via this bypass switch. When an abnormal condition is detected, the static bypass switch will be switched OFF and the inverter will be controlled to inject a desired missing voltage in series with the supply voltage to ensure the power supply of sensitive loads. There are totally two different kinds of control strategies in the proposed PB-AVQR system. When the grid voltage is lower than the rated voltage, an in-phase control strategy will be adopted and a phase-shift control strategy will be applied when the supply voltage is higher than the nominal voltage.

Working principle of the PB-AVQR is different compared with that of the DySC due to its unique shunt

converter structure. When the proposed configuration is analyzed, both the operating states of the switches (V1, V2) and the trigger angles of the thyristors (VT1, VT2) should be taken into consideration. So, a simplified PB-AVQR (SPB-AVQR) circuit shown in Fig. 2 where two thyristors (VT3, VT4) in the proposed PB-AVQR are replaced by two diodes (D1, D2), is firstly introduced to better explain its working principles. The following analysis will be based on the SPB-AVQR which can be regarded as a special type of PB-AVQR.

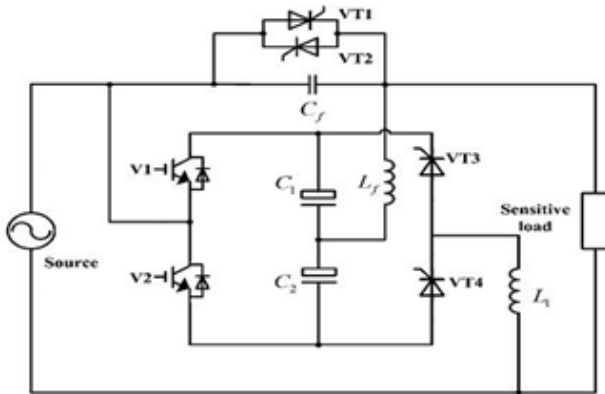

Fig.1.Proposed PB-AVQR topology

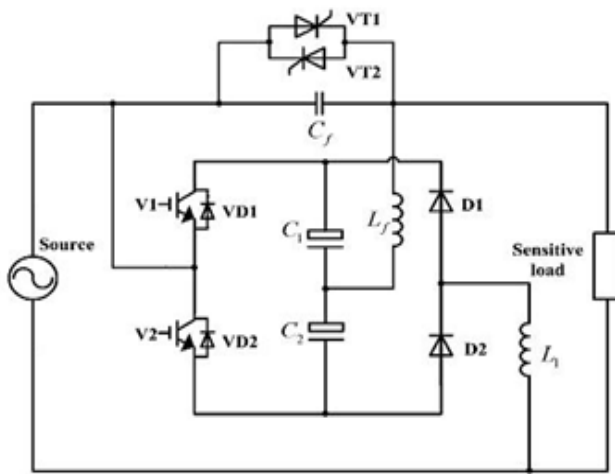
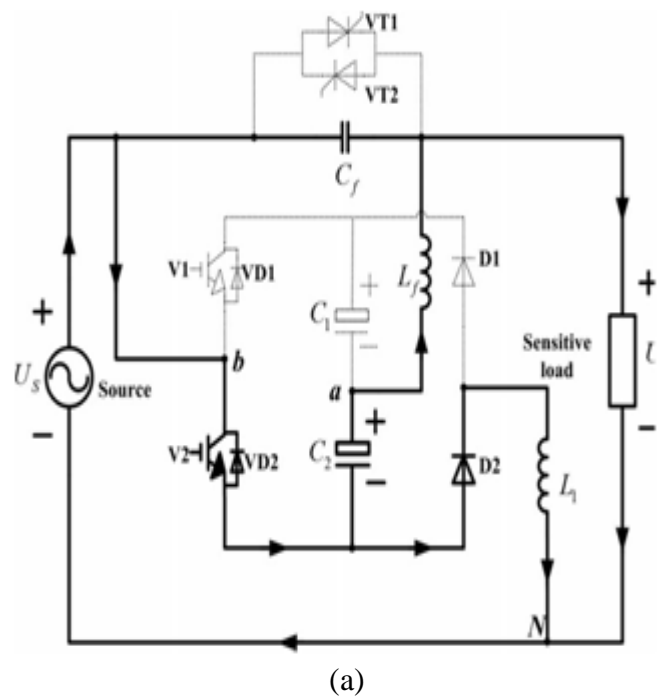

Fig.2.SPB-AVQR topology.

The only difference between these two configurations is that the shunt converter of the PB-AVQR is controllable while the shunt converter of the SPB-AVQR is uncontrollable. That is to say, the dc-link voltage of the SPBAVQR represents the upper limit of the dc-link voltage in the PB-AVQR structure. So, theoretical conclusions drawn with the SPB-AVQR are basically applicable to the PB-AVQR. As shown in Fig. 2, switches V1 and V2 are now also parts of the parallel circuit, which means that the dc-link voltage will be affected by the on/off status of the switches. So, the turn on and turn off conditions of the compensation process should be considered to understand the working principles about the parasitic boost circuit of the SPB-AVQR. Figs. 3 and 4

illustrate four different operating conditions of the SPB-AVQR within one switching cycle during the positive and negative half-cycle of the sinusoidal supply voltage separately. Both the compensation process and charging process can be explained based on these operating conditions.

In Figs. 3 and 4, the solid line means that there is current flowing through and arrows depict directions. Operating conditions during the positive half-cycle are illustrated in Fig. 3. When V2 is switched on, as shown in Fig. 3(a), the grid charges the inductor L1 via the diode D2 and the capacitor C2 discharges to maintain the load voltage. When V2 is switched off, as shown in Fig. 3. (b), the energy stored in the inductor during previous period is released to dc-link capacitors C1 and C2 through VD1 which is the anti parallel diode of V1. Operating conditions during the negative half-cycle are given in Fig. 4. When V1 is switched on, as shown in Fig.4 (a), the inductor L1 is charged via the diode D1, and the load is compensated by the capacitor C1. When V1 is switched off, as shown in Fig. 4(b), the energy stored in L1 is released through VD2, which is the anti parallel diode of V2, to capacitors C1 and C2. So, in each half-cycle of the grid, one capacitor of the dc-link discharges to provide the energy needed for the compensation, and this energy is actually obtained from the supply source via the charging process described earlier. Apparently, the charging circuit of the proposed configuration works exactly like a boost circuit and the dc-link voltage in this situation is controlled by the duty ratio of the two switches.



(a)

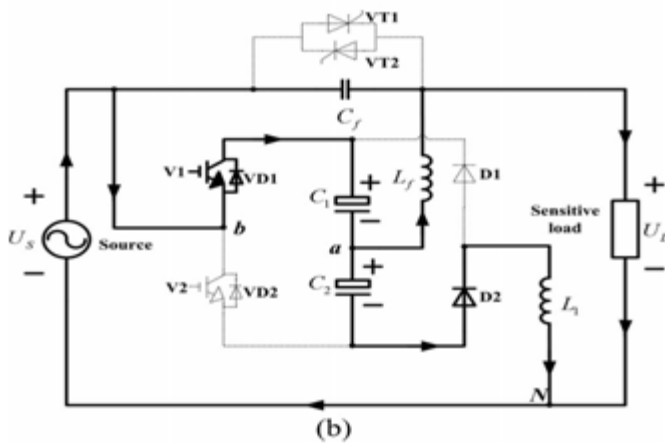
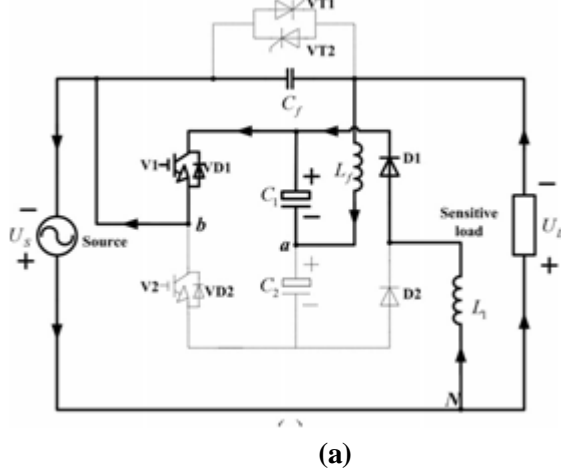
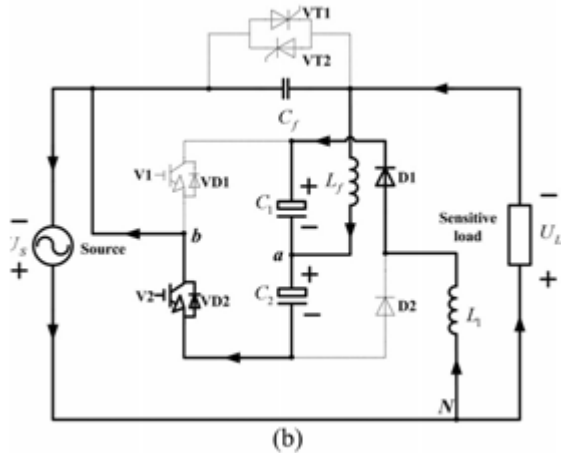

Fig.3. Operating conditions during positive half-cycle. (a) V2 switched on.(b) V2 switched off.



(a)



(b)

Fig. 4. Operating conditions during negative half-cycle.(a) V1 switched on. (b) V1 switched off.

So, the compensation ability of the SPB-AVQR is theoretically unlimited as long as the grid is strong enough to provide the needed power. However, as the boost circuit is parasitic on the series inverter, and the two switches are actually controlled according to the missing voltage, there still exist some restrictions. The relationships between the dc-link voltage and other system parameters will be discussed in the

next section. In Figs. 3 and 4, two endpoints of the inverter are marked as a and b. Parts of the waveforms obtained at the inverter side and load side under four operating conditions can be drawn. So, the load voltage will be maintained at its rated value if the inverter is properly controlled according to the required missing voltage during sags.

III. MODELING AND THEORETICAL ANALYSIS

DC-link voltage is a key parameter to evaluate the compensation ability about a series compensation device since it decides the maximum value of the injected compensation voltage. In this section, in order to evaluate the compensation ability of the proposed topology and verify its feasibility in mitigating long duration deep sags, relationships between the dc-link voltage and other system parameters will be derived based on the circuit model of the aforementioned operating conditions. As can be seen from Figs.3 and 4, working principles during the positive and negative half-cycle of the supply voltage are the same, so the following analysis will be focused on the situation in the positive half-cycle. The control strategy applied for voltage sags is in-phase compensation, so the energy needed to maintain the load voltage in one half-cycle can be expressed as follows

$$E_0 = \frac{T_0 \Delta V}{2V_{ref}} P_0$$

Where T_0 is the grid voltage period time, V_{ref} is the rated rms value of the load voltage, P_0 is the rated load power, and ΔV is the rms value of the missing voltage. In steady-state compensation, the energy needed for the compensation should completely be provided by the residential grid which is also the charging energy through the parasitic boost circuit in this case.

IV. MATLAB/SIMULINK RESULTS

In order to show the validity of the proposed PB-AVQR, simulation results are presented in this section. The simulation results are based on the MATLAB. There are mainly four parameters need to be designed, namely the dc-link capacitor C_1 / C_2 , the filter inductor L_f , the filter capacitor C_f , and the charging inductor L_1 . During the steady-state compensation, one capacitor discharges at the switched-on position and two capacitors are both charged at the switched-off position in each switching cycle.

Furthermore, C_1 and C_2 discharge, respectively, in the negative and positive half-cycle of the supply. So, if the two capacitors are treated equally during the charging process,

the energy-balance equation that required for the capacitors can be written as

$$\frac{T_0 \Delta V}{4V_{ref}} P_0 = \frac{1}{2} C_{1(2)} V_{dc}^2 - \frac{1}{2} C_{1(2)} (V_{dc} - v_{dc})^2$$

Where as v_{dc} is the fluctuation voltage of V_{dc} . In the theoretical analysis, the dc-link voltage is assumed to be a constant, so v_{dc}/V_{dc} here is limited within 5% at the voltage drop of 50% to minimize the overall dc-link voltage ripple. In this way, the estimated minimum value of C_1 / C_2 can be calculated with V_{dc} substituted by the dc-link set value V_{dc-set} . How to set the dc-link value it is given as

$$V_{dc-set} = \begin{cases} 1.2 \times \sqrt{2}(V_{ref} - V_S) + 40 & V_S < V_{ref} \\ 1.5 \times \sqrt{2}(V_S^2 - V_{ref}^2) + 40 & V_S > V_{ref} \end{cases}$$

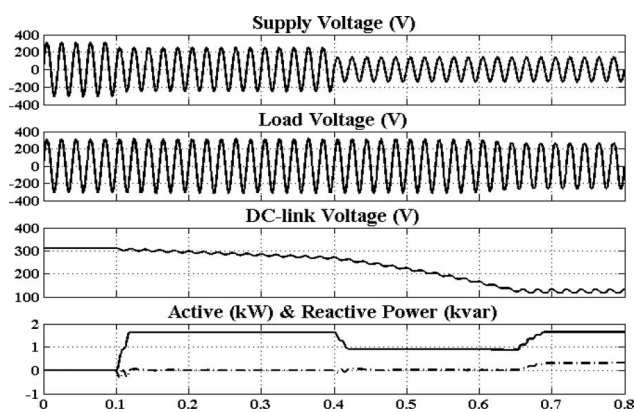

Fig. 5. Simulation result of the DySC.

Higher dc link voltage will be obtained with smaller L_1 , but peak value of the charging current will get larger at the same time. So, charging inductance L_1 is designed as a result of the compromise between the compensation ability and the charging current peak value. The main function of the output LC filter in the proposed structure is to eliminate the harmonic components of the injected compensation voltage. The value of L_f and C_f are designed according to its natural frequency and several other criterions which are given as follows:

$$\begin{cases} \frac{1}{2\pi\sqrt{L_f C_f}} = \chi f_s \\ L_f < \frac{v_L}{\omega_0 I_{Lmax}} \\ C_f < \frac{I_{ripple}(\chi^2 + 1)}{8V_{dc} f_s} \end{cases}$$

Where f_s is the switching frequency, v_L is the voltage drop across the inductor L_f at I_{Lmax} , I_{Lmax} is the maximum value of the load current, I_{ripple} is the maximum ripple current of the filter and χ is the coefficient between the

switching frequency and the filter's natural frequency. Generally, χ ranges from 0.05 to 0.2.

Fig 5 shows the simulation results of the DySC topology with different supply voltages. In the simulation, the supply voltage drops to 180 V at 0.1 s and then falls to 100 V at 0.4 s. As shown in Fig.5, when the supply voltage is 180V, the DySC can effectively compensate for the voltage sag; however, when the supply voltage drops to 100 V, the load voltage becomes not sinusoidal as the maximum injected compensation voltage is limited by the low steady-state dc-link voltage. Fig. 5 also indicates that the DySC can only mitigate deep sags for a few line cycles depending on the energy stored in dc-link capacitors as its steady-state dc-link voltage is always lower than the peak value of the supply voltage. The graphics of the active and reactive power are also included in Fig. 5. When the supply voltage is 180 V, the dc-link voltage does not reach its steady state value with limited simulation time, so the active power of the supply is lower than the load power and its value is about 1.6 kW. When the dc-link voltage reaches its steady-state value with 100 V supply voltage, the active power of the supply is about 1.65 kW which means that the load voltage is no longer maintained.

The simulation results of the proposed PB-AVQR topology under the same condition is shown in Fig.6

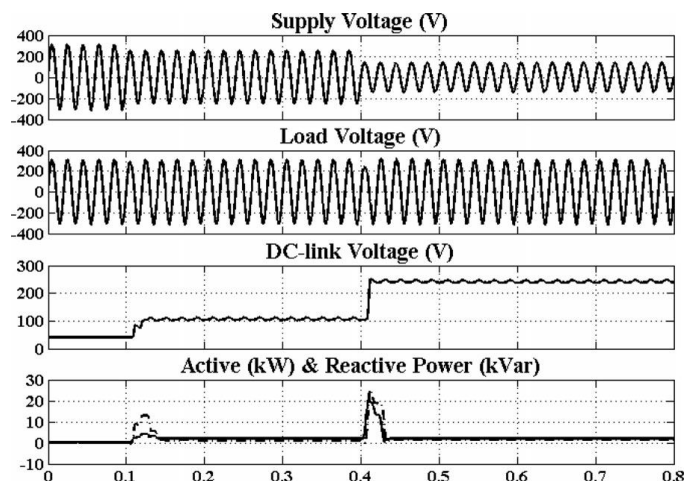

Fig 6 Simulation result of the PB-AVQR

As shown in Fig 6 when supply voltage changes, the dc-link voltage precisely tracks V_{dc-set} . Fig.6 also indicates that the transient response here is not very good, but this can be improved by increasing the set value for dc-link voltage. The active power of the supply during the steady-state compensation is 2 kW, and it is the same as the load power which means that the load voltage is effectively ensured. The reactive power during the steady-state compensation is about

1.1 kvar with 180 V supply and is about 1.4 kvar with 100 V supply. The reactive power of the proposed PB-AVQR is higher than that of the DySC due to the dc-link voltage adaptive control method. Additionally, the instantaneous value of the active and reactive power can be suppressed by properly designing V_{dc} -set and the charging time of the capacitors.

V. CONCLUSION

The proposed topology is derived from DySC circuit and compensation ability highly improved without increasing cost, weight, complexity and volume. For long duration deep sag PB-AVQR is cost effective solution compared with traditional DVR with load side connected shunt converter as series transformer no longer needed. The PB-AVQR is considered to be an efficient solution due to its relatively low cost and small size, also it has a fast dynamic response. Principle of working of PB-AVQR and circuit equations are given through theoretical analysis. To verify feasibility and effectiveness of proposed topology for the compensation of long duration deep sag that are lower than half of its rated voltage simulation result are presented by using the Dc link voltage adaptive control technique the operating efficiency of PB-AVQR system also remain at high level. Hence the PB-AVQR topology provides novel solution with great reliability and compensation performance for deep voltage sag.

VI. ACKNOWLEDGEMENT

I am greatly indebted forever to my guide, to my HOD and all teaching and non teaching staff those who support directly and indirectly to complete my project in time. I sincerely thank to my principal for their continuous encouragement and active interest in my progress that they gave throughout the work.

I am grateful to have my masters degree (EPS) from Matsyodari Shikshan Sanstha 's college of engineering and technology. JALNA, MAHARASHTRA.

REFERENCES

- [1] Tarek I El-Shennawy, Abdel-Mon'em Moussa, Mahmoud A El-Gammal and Amr Y Abou-Ghazala "A Dynamic Voltage Restorer for Voltage Sag Mitigation in a Refinery with Induction Motors Loads" 2010 Science Publications
- [2] Chellali Benchaiba, Brahim Ferdi "Voltage Quality Improvement Using DVR" Electrical Power Quality and Utilization, Journal Vol. XIV no. 1, 2008
- [3] Y. H. Chen, C. Y. Lin, J. M. Chen, and P. T. Cheng, "An inrush mitigation technique of load transformers for the series voltage sag compensator," IEEE Trans. Power Electron., vol. 25, no. 8, pp. 2211–2221, Aug. 2010.
- [4] M. F. McGranaghan, D. R. Mueller, and M. J. Samotyj, "Voltage sags in industrial systems," IEEE Trans. Ind. Appl., vol. 29, no. 2, pp. 397–403, Mar./Apr. 1993.
- [5] A. Bendre, D. Divan, W. Kranz, and W. Brumsickle, "Equipment failures caused by power quality disturbances," in Proc. IEEE IAS Conf. Record, 2004, pp. 482–489.
- [6] M. F. Alves and T. N. Ribeiro, "Voltage sag: an overview of IEC and IEEE standards and application criteria," in Proc. IEEE Transmiss. Distrib. Conf., 1999, vol. 2, pp. 585–589.
- [7] Shairul Wizmar Wahab and Alia Mohd Yusof "Voltage Sag and mitigation Using Dynamic Voltage Restorer (DVR) System" Faculty of Electrical Engg, University Of Malaysia