

# Design of Line Impedance Stabilization Network Based on CISPR Standard

A. Backia Abinaya<sup>1</sup>, S. Arokia Magdaline<sup>2</sup>

<sup>1,2</sup>Department of ECE

<sup>1,2</sup>Parisutham Institute of Technology and Science, N.H.64.Ring Road, Kamaraj Nagar, N.K, Thanjavur

**Abstract-** *The aim of this paper is to design a Line Impedance Stabilization Network based on CISPR Standard to diagnose the EMI level in the equipment. The details will be described how to design and stabilize the impedance of LISN at frequency range 30 MHz. As a practical measure to ensure EMC, a variety of equipment design and performance standards have evolved and been published by different agencies from time to time. These standards aim to set reasonable and rational limits for electromagnetic emission levels by different equipment, as well as immunity levels for such equipment. LISN is an device which used in conducted and radiated radio-frequency emission according to various Electromagnetic compatibility (EMC)/EMI test standard like CISPR,MIL-STD,FCC.*

**Keywords-** EMI, EMC, LISN, CISPR, FCC, RF.

## I. INTRODUCTION

EMI can be defined as electromagnetic energy which affects the functioning of an electronic device. Sources of EMI can sometimes be naturally occurring environmental events, such as electrical storms and solar radiation; but more often than not, the EMI source is another electronic device or electrical system. While EMI can be generated from any electronic device, certain equipment and components – such as cellphones, welders, motors and LED screens – are more likely to create disturbances than others. Because it is rare for electronics to operate in isolation, products are generally engineered to function in the presence of some amount of EMI. This is particularly important in military-grade and avionics equipment, as well as devices requiring superior reliability in all situations.

EMC is a measure of a device's ability to operate as intended in its shared operating environment while, at the same time, not affecting the ability of other equipment within the same environment to operate as intended. Evaluating how a device will react when exposed to electromagnetic energy is one component of this, known as immunity (or susceptibility) testing. Measuring the amount of EMI generated by the device's internal electrical systems – a process known as emissions testing – is another.

Both aspects of EMC are important design and engineering considerations in any system. Failing to properly anticipate the EMC of a device can have a number of negative consequences, including safety risks, product failure and data loss. As a result, a wide range of testing equipment for EMC and EMI has been developed to give engineers a clearer picture of how a device will operate in real-world conditions.

Emission testing requires the use of EMI measurement equipment such as receiving antennas, amplifiers and spectrum analyzers. Working together, these tools provide an accurate measurement of the amount and type of noise generated by a device. This can be done either on an open area test site or in a shielded, anechoic (or semi-anechoic), test chamber.

Susceptibility testing involves determining the ability of a device to tolerate noise from external sources. In order to do this, it is necessary to have tools that can simulate and measure electromagnetic energy specific frequencies. EMC testing equipment may be used to subject a device to electromagnetic noise at various frequencies, to simulate a power surge or to assess the effectiveness of a device's power supply. Ultimately, the nature of the device, its intended application and any regulatory requirements will determine which type of testing equipment is required.

## II. EMC

### A. Objective of EMC

A system is electromagnetically compatible with its environment if it satisfies three criteria:

1. It does not cause interference with other systems.
2. It is not susceptible to emissions from other systems.
3. It does not cause interference with itself.

### B. EMC Standard

In this topic, we present an account of the EMI/EMC standards. This treatment is not an exhaustive and complete description of any one specific standard, or of instrumentation

for test and measurement as given in a particular standard. Instead, the objective is to familiarize the reader with several practical aspects of EMC standards, and some major published standards in this field.

### C. CISPR Standard

The Europe-based Comite International Special des Perturbations Radioelectrique (CISPR) has been actively engaged since the 1930s in developing international standards concerning EMI/EMC, and that these have been published by the International Electro technical Commission (IEC). The CISPR/IEC effort is an international effort involving not only European nations but also non-European nations such as Australia, Canada, India, Japan, Korea, and the United States.

As with ANSI/IEEE standards, the IEC/CISPR documentation and standards are recommendations only. It is left to the participating nation and other nations to determine what part of these recommendations will be implemented in their countries and how they will be implemented. The test beds and the test procedures described generally enable compliance testing with corresponding IEC/CISPR standards.

## III. CONTROLLING MEASURES

Different controlling measures are available to prevent the equipment from EMI and also it is used to enhance the performance of the equipment. The sources of electromagnetic interference (EMI) are many. These may be from individual circuit design, engineering, or layout. Electromagnetic radiations and consequent interactions, or conducted interferences from one part of a circuit, equipment, or system to another, also result in EMI.

### A. Shielding

Electromagnetic shielding is the technique that reduces or prevents coupling of undesired radiated electromagnetic energy into equipment, so to enable it to operate compatibly in its electromagnetic environment. Electromagnetic shielding is effective in varying degrees over a large part of the electromagnetic spectrum from DC to microwave frequencies.

Shielding problems are difficult to handle because perfect shielding integrity is not possible because of the presence of intentional discontinuities in shielding walls. Such as shielding panel joints, ventilation holes, visual access windows, or switches. This section presents a discussion and analysis of shielding including these problems.

### B. Grounding

EMC ground is a zero impedance plane for voltage reference of signals. In practice, because of the finite conductivity of the ground plane, stray ground current through the common impedance between two ground points produces conductively coupled interference between two circuits as shown in Figure The purposes of EMC grounding are (1) realization of the signal, power, and electrical safety paths necessary for effective performance without introducing excessive common-mode interference, and (2) establishment of a path to divert interference energy existing on external conductors, or present in the environment, away from susceptible circuits.

### C. Electrical Bonding

Electrical bonding is a process in which components or modules of an assembly, equipment or subsystems are electrically connected by means of a low impedance conductor. Ideally, the interconnections should be made so that the mechanical and electrical properties of the current path are determined by the connected members and not by the joints. The joint must maintain its mechanical and electrical properties over an extended period of time. The purpose is to make the structures homogeneous with respect to the flow of RF currents. There are several factors that influence the EMI performances of the bonding.

### D. Filtering

Filtering is an important mitigation technique for suppressing undesired conducted electromagnetic interference (EMI). When a system incorporates shielding, undesired coupling caused by radiated EMI is reduced. Conducted EMI currents in the power supply lines and signal input/output lines are filtered out at the entrance to the shielding facility.

## IV. LISN

An LISN is a low-pass filter typically placed between an AC or DC power source and the EUT (Equipment Under Test) to create a known impedance and to provide a Radio frequency (RF) noise measurement port. It also isolates the unwanted RF signals from the power source. In addition, LISNs can be used to predict conducted emission for diagnostic and pre-compliance testing. Conducted emissions compliance testing involves the use of a LISN; also called an Artificial Network (AN). It is the standard prescribed means of powering the device for testing and it provides a port for measuring the conducted noise levels. Expensive measuring equipment such as a spectrum analyzer or even a commercial

LISN does not warrant the cost of occasional EMI testing, thus the need for developing a verified low cost solution.

The line impedance stabilization networks called AMN: artificial mains network) are used to measure disturbance voltages on the mains cord of an electrical instrument. Different types of LISNs are available as required for the application and standard requirements based on their phase.

### A. LISN Basics

LISN (line impedance stabilization network) is a device used in conducted and radiated radio-frequency emission and susceptibility tests, as specified in various Electromagnetic compatibility (EMC)/EMI test standards (e.g., by CISPR, International Electro-technical Commission, CENELEC, U.S. Federal Communications Commission, MIL-STD, etc.) An LISN is a low-pass filter typically placed between an AC or DC power source and the EUT (Equipment Under Test) to create a known impedance and to provide a Radio frequency (RF) noise measurement port. It also isolates the unwanted RF signals from the power source. In addition, LISNs can be used to predict conducted emission for diagnostic and pre-compliance testing.

The functions of LISN are

1. Stable Line Impedance
2. Isolation of the power source noise
3. Safe connection of the measuring equipment

### B. LISN Types

A Under a particular EMC test standard, a specific LISN type is required for evaluating and characterizing the operation of the EUT. Different types of LISNs are available for analyzing DC, single-phase or 3-phase AC power connections. The main parameters for selecting the proper type of LISN are impedance, insertion loss, voltage rating, current rating, number of power conductors and connector types. The upper frequency limit of the LISN also plays an important role when conducted emissions measurements are used for predicting radiated emissions problems.

### C. Schematic diagram and its function

LISN is an important tool for the conductivity EMI measurement. The development adopts the CISPR standards, which is constituted by a number of the standard capacitors, resistors, and inductors.

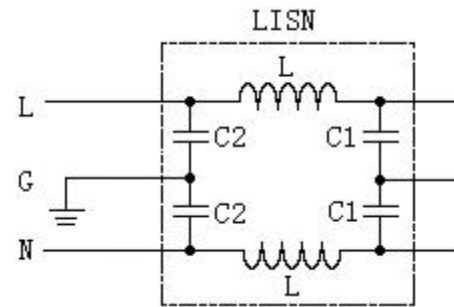

FIGURE 1.1 SCHEMATIC DIAGRAM OF LISN

LISN is an important tool for the conductivity EMI measurement. The development adopts the CISPR standards, which is constituted by a number of the standard capacitors, resistors, and inductors.

Its main function is as follows:

- 1) For the 50Hz low-frequency current: The inductance is like the short circuit, the capacitance is like the open circuit, so it can provide AC power to the equipment under test (EUT).
- 2) For the high-frequency noise of the EUT: The internal inductance of LISN is like the open circuit, the capacitance is like the short circuit. The noise current will therefore be feed to spectrum analyzer by LISN to make measurements. Thus, interference noise will not flow into the power grid. LISN provides the 50 input impedance as the test standard at the same time.
- 3) For the interference signal inflowing from supply-side: It can be isolated by the internal inductance and capacitance so that does not affect the system measurement.

### D. Filtering Technique

A filter is a device or process that removes some unwanted components or features from a signal. Filtering is a class of signal processing, the defining feature of filters being the complete or partial suppression of some aspect of the signal. Most often, this means removing some frequencies and not others in order to suppress interfering signals and reduce background noise. However, filters do not exclusively act in the frequency domain; especially in the field of image processing many other targets for filtering exist.

Four general filter functions are desirable:

- 1) Band-pass filter: select only a desired band of frequencies.
- 2) Band-stop filter: eliminate an undesired band of frequencies.
- 3) Low-pass filter: allow only frequencies below a cutoff frequency to pass.

- 4) High-pass filter: allow only frequencies above a cutoff frequency to pass.

**E. Low pass Filter Design**

Low pass filters are used in a wide number of applications. Particularly in radio frequency applications, low pass filters are made in their LC form using inductors and capacitors. Typically they may be used to filter out unwanted signals that may be present in a band above the wanted pass band. In this way, this form of filter only accepts signals below the cut-off frequency. Low pass filters using LC components, i.e. inductors and capacitors are arranged in either a pi or T network. For the pi section filter, each section has one series component and either side a component to ground. The T network low pass filter has one component to ground and either side there is a series in line component. There is a variety of different filter variants that can be used dependent upon the requirements in terms of in band ripple, rate at which final roll off is achieved, etc. The type used here is the constant-k and this produces some manageable equations:

$$L = Z_o / (\pi \times F_c) H$$

$$C = 1 / (Z_o \times \pi \times F_c) F$$

$$F_c = 1 / (\pi \times \text{square root} (L \times C)) Hz$$

Where,  
 Zo = characteristic impedance in ohms .  
 C = Capacitance in Farads  
 L = Inductance in Henries.  
 Fc = Cutoff frequency in Hertz.

**F. Band pass Filter Design**

A band-pass filter is a device that passes frequencies within a certain range and rejects (attenuates) frequencies outside that range. There are two types of design method used commonly.

**FORMULA:**

$$C = g/R_o\omega_c$$

$$L = R_o g/\omega_c$$

**DESIGN FLOW**

- 1) Select Response
- 2) Find Order N
- 3) LP prototype design
- 4) Impedance Conversion
- 5) Transformations

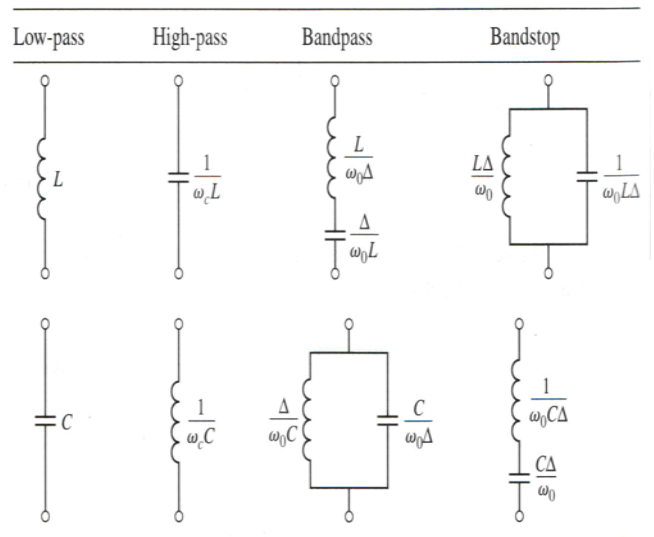

FIGURE 1.2 TRANSFORMATIONS

**V. RESULTS**

The impact of the environment upon the test results must be considered before measure. It only need to disconnect EUT on the signal test path, read and save the environment test data in software, add the measured electromagnetic environment data to the test curve when measure. The automatic test software user interface, and it shows the test curve of the environmental interference signal in the common laboratory environment. The software has successfully completed the collection, processing and display of the environmental interference signal.

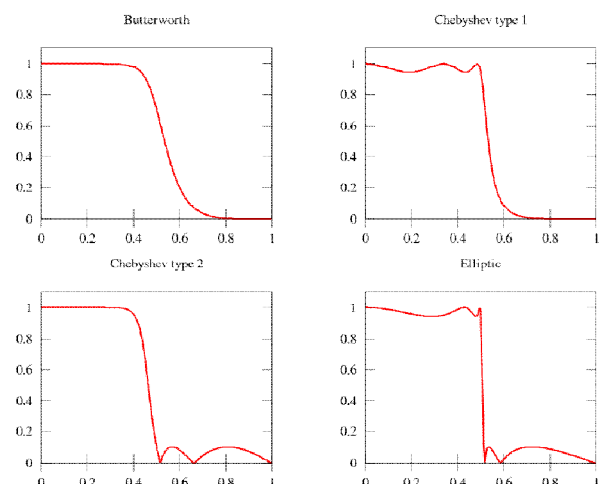

FIGURE 1.3 RESPONSE GRAPH

This paper designed an asymmetry conduct interference pre-testing system of power supply line of the equipment. The pre-testing system has gotten the expected results through the experiment. As long as the electromagnetic

environment has been reasonably chose, (for example, layout the test equipments as possible as you can in accordance with the requirements of the standards, keep away from the high-power and high-frequency electric and electronic equipment), the interference value of test frequency point can qualitatively respond to the interference of the power supply end of the EUT, so as to provide a reference for the design of EUT and improve the one-time pass rate of the product certification testing. As long as carry out the appropriate expansion for part of automatic test software function modules, with the radiation interference test equipment, we also could make the corresponding test processing and display for the radiation interference value. But if you want to get the accurate interference value, it was required to use the professional equipments to test in the shield room in accordance with the requirements of EMC standards.



FIGURE 1.4 REAL TIME IMPLEMENTATION

## VI. CONCLUSION

In this research work from all of the experimental results, it can be concluded that the proposed LISN can be provided the defined impedance 50 ohm. EMI radiation causes severe health effects to human beings. To avoid the degradation of equipment performance LISN device is used. It also helps to get better accuracy and efficiency.

## ACKNOWLEDGMENT

It is a matter of great pleasure by getting the opportunity of highlighting a fraction of knowledge, I acquired during our technical education through this paper. I would express my profuse thanks to our head of the department and all staff members of ECE department who have helped for the successful completion of this paper.

## REFERENCES

- [1] Chetan Kathalay,(2015) “A practical approach to EMC “ by EMC Publications,pune,Edition 1.
- [2] Clayton R Paul,(2006) “Introduction to EMC”, Second Edition,John Wiley and sons,Inc. Publication,.
- [3] Costa(2014) EMC in Power Electronics,USA WILEY.
- [4] Francois Ziade, (February 2016) “Improvement of LISN Measurement Accuracy Based on Calculable Adapters” in IEEE Transactions on Instrumentation and Measurement, Vol. 65, No. 2.
- [5] Grobler, “Low cost power lead extended pre-compliance conducted EMI measurement setup and diagnostics with compact LISN” in 10.1109/ECCE-Asia.2013.6579252.
- [6] Grobler, “Low cost power lead extended pre-compliance conducted EMI measurement setup and diagnostics with compact LISN” in 10.1109/ECCE-Asia.2013.6579252.
- [7] Henry W.Ott, (2009) “Electromagnetic Compatibility Engineering”, Wiley Publication,.
- [8] Kang-Rong Li, (2016) “Impact Analysis of Conducted Emission Measurement without LISN” in IEEE Transactions on Electromagnetic Compatibility, Vol. 58, No. 3, June.
- [9] Shreenivas Jog, (2015) “Electromagnetic Compatibility of Energy Efficient SMPS with CISPR EMI Standards” in International Conference on Energy Systems and Applications ICESA.
- [10] Takashi Shinozuka, “Calibration Methods for AC-Coaxial Adapter Used in AMN Impedance Measurements” in IEEE Transactions on Electromagnetic Compatibility.
- [11] V.Tarateeraseth, K. Y. See, Canavero, and K.C.A Chang, (2010) “Systematic electromagnetic interference filter design based on information from in-circuit impedance measurements,” IEEE Trans. Electromagnetic Compatibility, vol. 52, no. 3, pp. 588–598.
- [12] Yi Sun, (2009) “Development of a New Line Impedance Stabilization Network” in Microwave, Antenna, Propagation and EMC Technologies for Wireless Communications, 3rd IEEE International Symposium 10.1109/MAPE.2009.5355743.
- [13] Yi Sun, (2009) “Development of a New Line Impedance Stabilization Network” in Microwave, Antenna, Propagation and EMC Technologies for Wireless Communications, 3rd IEEE International Symposium 10.1109/MAPE.2009.5355743.
- [14] Y. Yorozu, M. Hirano, K. Oka, and Y. Tagawa, “Electron spectroscopy studies on magneto-optical media and

plastic substrate interface,” IEEE Transl. J. Magn. Japan, vol. 2, pp. 740-741, August 1987 [Digests 9th Annual Conf. Magnetism Japan, p. 301, 1982].

[15] M. Young, *The Technical Writer’s Handbook*. Mill Valley, CA: University Science, 1989.