

# Low Cost Surveillance Using Raspberry Pi through Email

Mr. Nikhil Gajjam<sup>1</sup>, Mr. P. S. R. Patnaik<sup>2</sup>, Mr. D. P. Gandhmal<sup>3</sup>, Mr. V. A. Bingi<sup>4</sup>

<sup>1, 2, 3, 4</sup> Department of Computer Science & Engineering  
<sup>1, 2, 3, 4</sup> Walchand Institute of Technology, Solapur

**Abstract-** Recently raspberry pi replaced computer in most of the needy applications by taking advantage of size, cost. This application captures image using raspberry pi and camera whenever needed, instead of storing continuous streaming video on the hard disk. The communication between user and raspberry pi is done using one of the mailing servers.

This surveillance system captures the image on user's request which is made via his email to the raspberry pi. Raspberry pi authenticates the email and captures the image the moment email is received. The image is attached to the email and is sent to user as a response.

**Keywords-** Raspberry pi, surveillance, python, email.

## I. INTRODUCTION

Surveillance system is becoming more and more important for the purpose of observing important areas. Involving email in this project is to observe those areas from remote places through mobile or desktop easily. Most of the applications like small factories, classrooms in school or colleges, medical shops etc. continuous video streaming is not important. In those cases single image will be enough. In such applications this project will be prove to be handy.

### Raspberry pi:

It is small size computer with Raspbian operating system default installed in it. Due to the unique advantages of the Raspberry Pi, it provides many solutions within the developing world. Raspberry Pi 1 Model B, Raspberry Pi 1 Model B+, Raspberry Pi 2, Raspberry Pi 3 Model B is the different variants of raspberry pi. Raspberry pi 3 model B is the latest model and is bundled with on-board WiFi and Bluetooth.

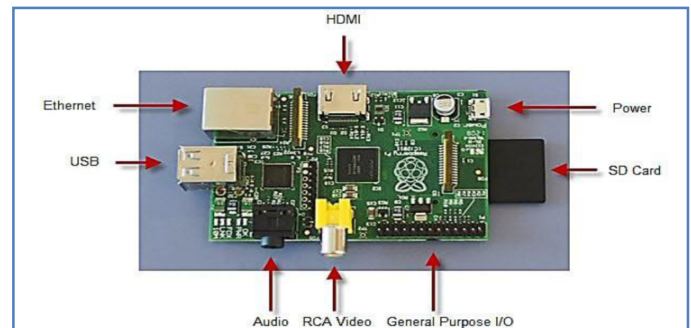

Figure 1: Raspberry pi model B

### Raspberry pi camera:

Raspberry Pi camera is used in this system, to capture the image. High-definition video and images can be captured using this camera. It's a five megapixel fixed-focus camera. A 15cm ribbon cable is used to connect the camera with the Raspberry Pi board [1].

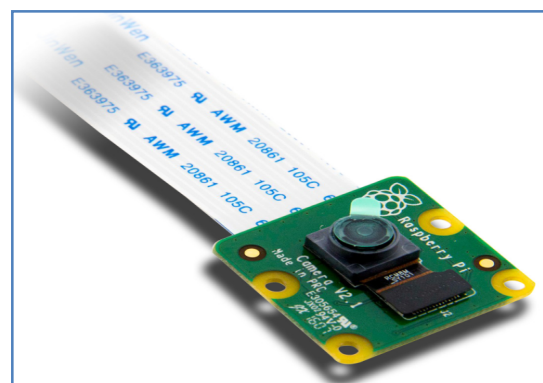

Figure 2: Raspberry pi camera

Python is a powerful, easy-to learn programming language based on traditional languages but better suited to current operating systems, networks, and hardware [10].

Python was chosen as the main programming language, as it is generally accepted to be both easy to learn and a fully fledged, programming language suitable for real world applications. With the addition of NumPy, SciPy, Matplotlib, IPython, and PyLab, Python can be used for computational mathematics as well as for the analysis of experimental data or control systems.

Advantage of using python language is native python compiler included in the Raspbian Wheezy.

**1.1 Related work**

In the paper “Design and Implementation of Security Systems for Smart Home based on GSM technology” [13] by Jayashri Bangali and Arvind Shaligram proposed the idea of security alert in terms of sound and mail on interrupt, alert will be given to the user as mail

“Smart Surveillance Monitoring System Using Raspberry Pi and PIR Sensor” proposed the idea of monitoring the particular place in remote area using smart phone. This system uses raspberry pi board and a camera to capture the information and sends it via a 3G dongle to the smart phone with the help of PIR sensor [5].

The paper titled “Android Based Home Automation Using Raspberry Pi” [2] by Shaiju Paul, Ashlin Antony, Aswathy B stated concept of controlling the appliances using android phones with the advantages of flexibility, scalability and security. The instructions are sent by the user from the remote area using the WiFi. The appliances are controlled using relay circuit and raspberry pi.

Sarthak Jain, Anant Vaibhav, Lovely Goyal presented paper on Raspberry Pi based Interactive Home Automation System through E-mail. In this paper they designed a basic home automation application on Raspberry Pi through reading the subject of E-mail and the algorithm for the same has been developed in python environment. In their work LEDs were used for indicating switching action [11].

**1.2 EXISTING SYSTEM**



Camera with 1280 x 1024 resolutions and with 1TB hard disk can store the 26 days of live video streaming. With large number security applications along with dozens of cameras and 24x7 video streams can require hundreds of

gigabytes of memory. So this work aims to replace this hard disk memory storage with single image whenever required.

**II. IMPLEMENTATION**

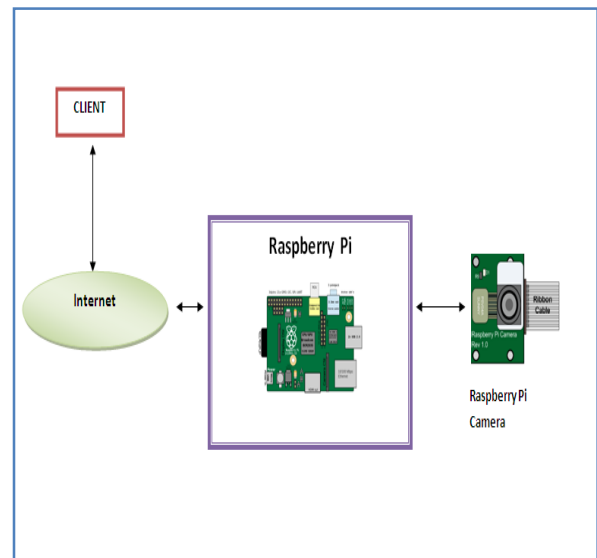

Figure 3: System architecture

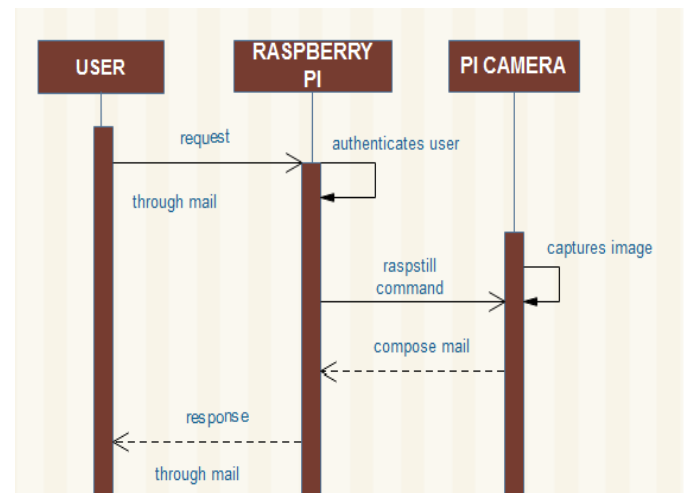

Figure 3: Sequence diagram of the project

Python programming language is used for reading the mail and sending email back to user as a response.

User makes the request to raspberry pi by sending mail. Raspberry pi continuously checks the server’s mail for the incoming request.

We have used 2 default mail ids as nikhilgajjam@gmail.com and solapurwalchand@gmail.com.

nikhilgajjam@gmail.com is the user mail id and solapurwalchand@gmail.com is server’s mail id where requests are to be sent.

User mail id	Server mail id
<a href="mailto:nikhilgajjam@gmail.com">nikhilgajjam@gmail.com</a>	<a href="mailto:walchandsolapur@gmail.com">walchandsolapur@gmail.com</a>

Raspberry pi continuously checks the server’s mail. Before capturing image, it authenticates every incoming mail. Authentication is done by checking the user’s mail\_id as well as subject of the mail. Image is captured only when the user’s mail id is nikhilgajjam@gmail.com and subject of the email is “Capture image”.

**Capturing image:**

Following command is used for capturing image in raspberry pi.

```
os.system("raspistill -v -o abcd.jpg");
```

-v option outputs the verbose information during execution.  
 -o used to specify the output filename of captured image.  
 abcd.jpg is the filename of the image and every time it is replaced with previous image.  
 “raspistill” is the command line tool for capturing still photographs with the camera module

Once the image is captured, mail is sent back to user with the captured image attached to it.

**III.RESULTS**

Fig. 4 is the composing mail request to servers mail address with “Capture image” as a subject.

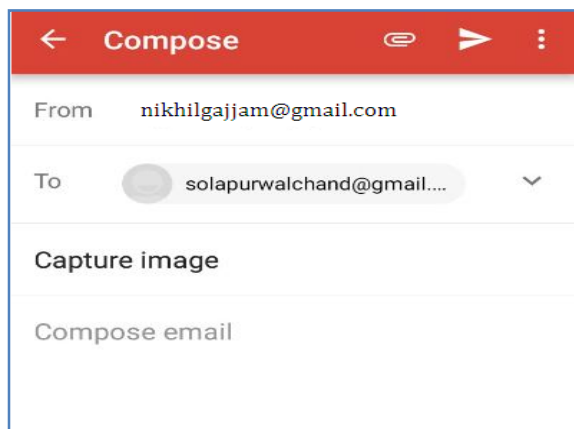

Figure 4: Result-user sending request mail

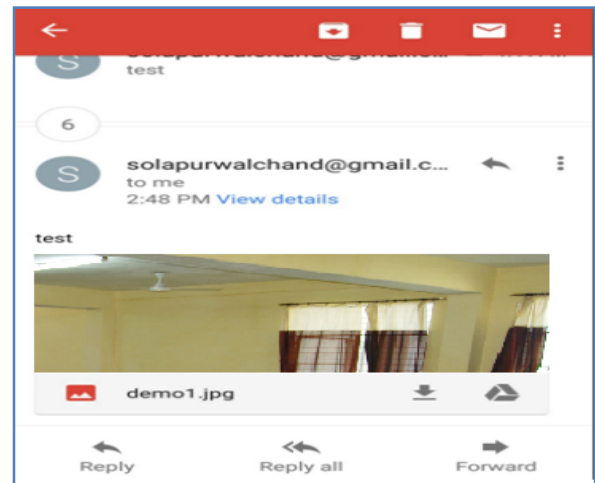

Figure 5: Result-user getting reply from raspberry pi

Fig. 5 is the response from server to user with captured image from raspberry pi camera.

**VI. SUMMARY**

Basic advantage of this work is to use surveillance system on user’s request only. There are many areas where continuous streaming of the video is not required. . In those cases single image is sufficient. In such applications this project will be prove to be handy. We have taken advantage of gmail server for communication between user and raspberry pi.

**REFERENCES**

- [1] Sarthak Jain, Anant Vaibhav and Lovely Goyal “Raspberry pi based interactive home automation system through e-mail”, 2014 International Conference on Reliability, Optimization and Information Technology - ICROIT 2014, India, Feb 6-8 2014
- [2] Shaiju Paul, Ashlin Antony and Aswathy.B “Android Based Home Automation Using Raspberry Pi”, International Journal of Computing and Technology, vol. 1, no. 1, February 2014.
- [3] E. Upton & G. Halfacree. Raspberry Pi. User Guide, John Wiley, 2012
- [4] Md. Nasimuzzaman Chowdhury, Md. Shiblee Nooman, Srijon Sarker, “Access Control of Door and Home Security by Raspberry Pi through Internet”, International Journal of Scientific & Engineering Research, Volume4, Issue11, november2013,ISSN:2229-5518.

- [5] Bruhathireddy, Dr. G. N. Kodandaramaiah, M. Lakshmiopathy “Design and Implementation of Home Automation system using Raspberry Pi”, International Journal of Science, Technology & Management, www.ijstm.com, Volume No. 03, Issue No. 12, December 2014, ISSN:2394-1537.
- [6] Sundas Zafar, Aparicio Carranza, " Motion Detecting Camera Security System with Email Notifications and Live Streaming Using Raspberry Pi"
- [7] Aamir Nizam Ansari, Mohamed Sedkyl, Neelam Sharma, Anurag Tyagil, An Internet of Things Approach for Motion Detection using Raspberry Pi, 2015 International Conference on Intelligent Computing and Internet of Things (ICIT),2015
- [8] A. Bradbury and B. Everard, “Learning Python with Raspberry Pi”, Wiley, 2014.
- [9] K. Lambert, “Fundamentals of Python: Data Structures”, Cengage Learning, 2013.
- [10] G. Lindstrom, “Programming with Python”, IEEE Computer Society, Oct. 2005, pp. 10–16.
- [11] Jain S, Vaibhav A, Goyal L. Raspberry based interactive home automation system through E-mail. ICROIT; Faridabad; 2014 Feb 6-8. p. 227–80
- [12] Sanjana Prasad, P.Mahalakshmi, A.Jhon Clement Sunder, R.Swathi, “Smart Surveillance Monitoring System using Raspberry Pi and PIR Sensor”, International Journal of Computer Science and Information Technologies, vol.5 (6), ISSN: 0975-9646, 2014
- [13] Jayashri Bangali and Arvind Shaligram” Design and Implementation of Security Systems for Smart Home based on GSM technology”, International Journal of Smart Home Vol.7, No.6 (2013), pp.201-208