

A Microstrip Patch Antenna Designed with Electronic Band Gap for Wireless Communication Devices

S.S.S.R. Rao¹, Raghu Kalyana²

^{1,2} Department of ECE

^{1,2} Kakinada Institute of Technology & Science, Divili, A.P, India

Abstract- To design a compact microstrip patch antenna for use in wireless/cellular devices. A typical cellular phone measures about 14.5 cm by 4.5 cm. Hence the antenna designed must be able to fit in such a cellular phone. I have to design a compact microstrip patch antenna having a center frequency of 2.5 GHz accordingly to reach the design and results. The ground plane dimensions for the patch antenna has been designed to be 28 mm by 28 mm and the patch dimensions are 28 mm by 28 mm. Hence the antenna is compact enough to be placed in a typical cellular phone.

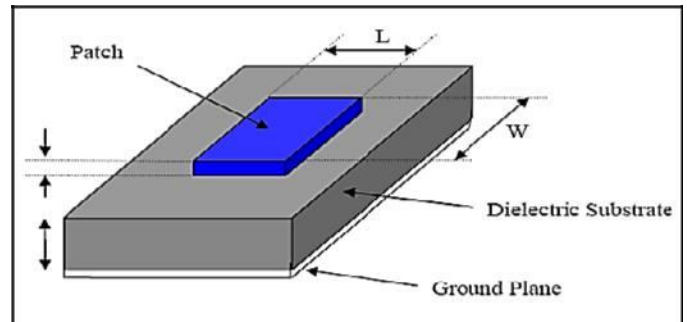

Fig.1 Structure of a microstrip Patch Antenna

I. INTRODUCTION

Micro strip patch antennas have some Limitations such as restricted band-width of operation, low gain and a potential decrease in radiation efficiency due to surface wave losses. The ability of an Electronic band gap Structure or Photonic band gap Substrate to minimize the surface wave effects is analyzed for a thick and high ϵ_r substrate. The thickness of the dielectric substrate being used, increases, surface waves and spurious feed radiation also increases, which hampers the bandwidth of the antenna. The return-loss going to be minimized with the increasing of the Electronic band gap structure

II. MICROSTRIP PATCH ANTENNA

In its most basic form, a Microstrip patch antenna consists of a radiating patch on one side of a dielectric substrate which has a ground plane on the other side as shown in Figure 1. The patch is generally made of conducting material such as copper or gold and can take any possible shape. The radiating patch and the feed lines are usually photo etched on the dielectric substrate.

In order to simplify analysis and performance prediction, the patch is generally square, rectangular, circular, triangular, and elliptical or some other common shape as shown in Figure 2.

For a rectangular patch, the length L of the patch is usually $0.3333\lambda_0 < L < 0.5\lambda_0$, where λ_0 is the free-space wavelength. The patch is selected to be very thin such that $t \ll \lambda_0$ (where t is the patch thickness). The height h of the dielectric substrate is usually $0.003 \lambda_0 \leq h \leq 0.5 \lambda_0$. The dielectric constant of the substrate (ϵ_r) is typically in the range $2.2 \leq \epsilon_r \leq 12$. The basic shapes that the patch can take are

Microstrip patch antennas radiate primarily because of the fringing fields between the patch edge and the ground plane. For good antenna performance, a thick dielectric substrate having a low dielectric constant is desirable since this provides better efficiency, larger bandwidth and better radiation[5]

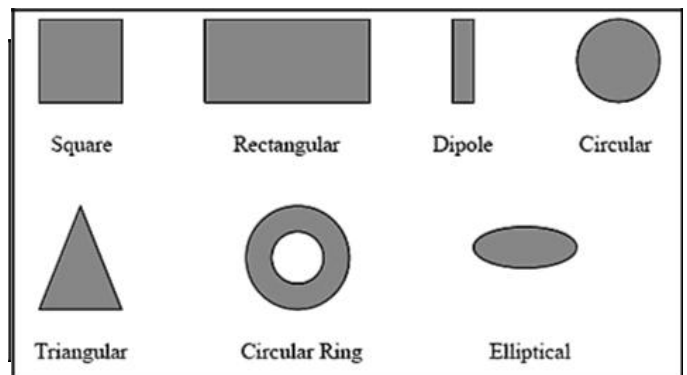

Fig. 2 Common shape of a microstrip Patch elements

However, such a configuration leads to a larger antenna size. In order to design a compact Microstrip patch antenna, higher dielectric constants must be used which are less efficient and result in narrower bandwidth. Hence a

compromise must be reached between antenna dimensions and antenna performance.

III. METHOD OF ANALYSIS

The most popular models for the analysis of Microstrip patch antennas are the transmission line model, cavity model, and full wave model [5] (which include primarily integral equations/Moment Method). The transmission line model is the simplest of all and it gives good physical insight but it is less accurate. The cavity model is more accurate and gives good physical insight but is complex in nature. The full wave models are extremely accurate, versatile and can treat single elements, finite and infinite arrays, stacked elements, arbitrary shaped elements and coupling. These give less insight as compared to the two models mentioned above and are far more complex in nature.

3.1 Transmission Line Model

This model represents the microstrip antenna by two slots of width W and height h , separated by a transmission line of length L . The microstrip is essentially a non-homogeneous line of two dielectrics, typically the substrate and air.

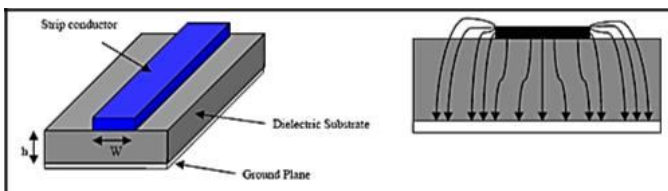

Fig. 3 Microstrip line & Electric Field Line

Hence, as seen from Figure 6, most of the electric field lines reside in the substrate and parts of some lines in air.

As a result, this transmission line cannot support pure transverse-electric-magnetic (TEM) mode of transmission, since the phase velocities would be different in the air and the substrate. Instead, the dominant mode of propagation would be the quasi-TEM e mode. Hence, an effective dielectric constant (ϵ_{eff}) must be obtained in order to account for the fringing and the wave propagation in the line. The value of is slightly less then because the fringing fields around the periphery of the patch are not confined in the dielectric substrate but are also spread in the air as shown in Figure 3 above. The expression for ϵ_{eff} is given by Balanis [12] as:

$$\epsilon_{reff} = \frac{\epsilon_r + 1}{2} + \frac{\epsilon_r - 1}{2} \left[1 + 12 \frac{h}{W} \right]^{-1/2} \tag{3.1}$$

Where ϵ_{ref} = Effective dielectric constant
 ϵ_r = Dielectric constant of substrate
 H = Height of dielectric substrate
 W = Width of the patch

Consider Figure 4 below, which shows a rectangular microstrip patch antenna of length L , width W resting on a substrate of height h . The co-ordinate axis is selected such that the length is along the x direction, width is along the y direction and the height is along the z direction.

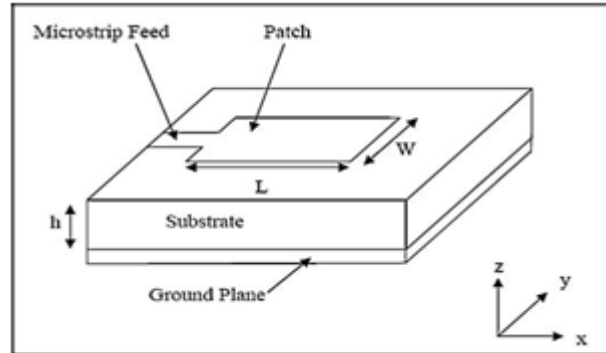

Fig.4 Microstrip patch Antenna

In order to operate in the fundamental TM_{10} modes, the length of the patch must be slightly less than $\lambda / 2$ where λ is the wavelength in the dielectric medium and is equal to $\lambda_o / \sqrt{\epsilon_{eff}}$ where λ_o is the free space wavelength. The TM_{10} mode implies that the field varies one $\lambda / 2$ cycle along the length, and there is no variation along the width of the patch. In the Figure 8 shown below, the microstrip patch antenna is represented by two slots, separated by transmission line of length L and open circuited at both the ends. Along the width of the patch, the voltage is maximum and current is minimum due to the open ends. The fields at the edges can be resolved into normal and tangential components with respect to the ground plane.

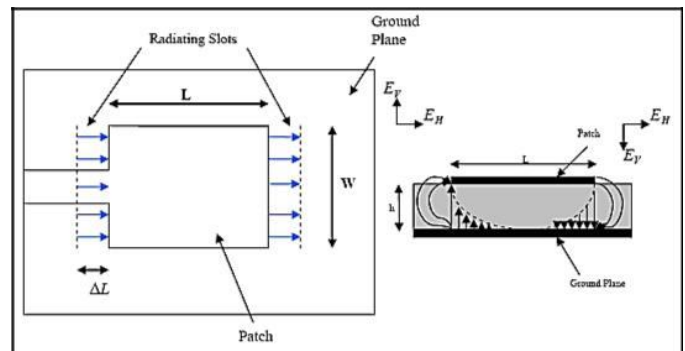

Fig. 5.Top & Side View of antenna

It is seen from Figure 5 that the normal components of the electric field at the two edges along the width are in

opposite directions and thus out of phase since the patch is $\lambda / 2$ long and hence they cancel each other in the broadside direction. The tangential components (seen in Figure 5), which are in phase, means that the resulting fields combine to give maximum radiated field normal to the surface of the structure. Hence the edges along the width can be represented as two radiating slots, which are $\lambda / 2$ apart and excited in phase and radiating in the half space above the ground plane. The fringing fields along the width can be modeled as radiating slots and electrically the patch of the microstrip antenna looks greater than its physical dimensions. The dimensions of the patch along its length have now been extended on each end by a distance ΔL , which is given empirically by Hammers tad [13] as:

$$\Delta L = 0.412h \frac{(\epsilon_{r,eff} + 0.3) \left(\frac{W}{h} + 0.264 \right)}{(\epsilon_{r,eff} - 0.258) \left(\frac{W}{h} + 0.8 \right)} \quad (3.2)$$

The effective length of the patch L_{eff} now becomes:

$$L_{eff} = L + 2\Delta L \quad (3.3)$$

For a given resonance frequency f_o , the effective length is given by [9] as:

$$L_{eff} = \frac{c}{2f_o \sqrt{\epsilon_{r,eff}}} \quad (3.4)$$

For a rectangular Microstrip patch antenna, the resonance frequency for any TM_{mn} mode is given by James and Hall [14] as:

$$f_o = \frac{c}{2\sqrt{\epsilon_{r,eff}}} \left[\left(\frac{m}{L} \right)^2 + \left(\frac{n}{W} \right)^2 \right]^{\frac{1}{2}} \quad (3.5)$$

Where m and n are modes along L and W respectively. For efficient radiation, the width W is given by Bahl and Bhartia [15] as:

$$W = \frac{c}{2f_o \sqrt{\frac{(\epsilon_r + 1)}{2}}} \quad (3.6)$$

3.2 Cavity Model

Although the transmission line model discussed in the previous section is easy to use, it has some inherent

disadvantages. Specifically, it is useful for patches of rectangular design and it ignores field variations along the radiating edges. These disadvantages can be overcome by using the cavity model. A brief overview of this model is given below. In this model, the interior region of the dielectric substrate is modeled as a cavity bounded by electric walls on the top and bottom. The basis for this assumption is the following observations for thin substrates ($h \ll \lambda$) [10].

- Since the substrate is thin, the fields in the interior region do not vary much in the z direction, i.e. normal to the patch.
- The electric field is z directed only, and the magnetic field has only the transverse components H_x and H_y in the region bounded by the patch metallization and the ground plane. This observation provides for the electric walls at the top and the bottom.

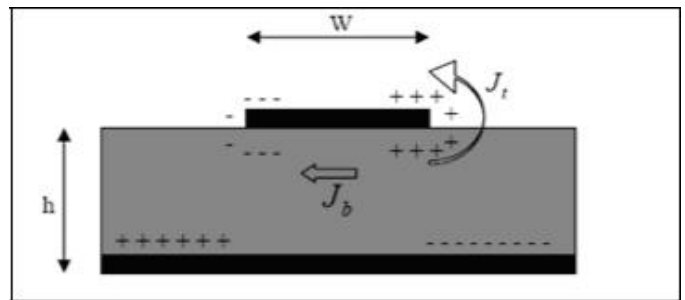

Fig.6 Charge distribution and current density creation on the microstrip patch

Consider Figure 6 shown above. When the microstrip patch is provided power, a charge distribution is seen on the upper and lower surfaces of the patch and at the bottom of the ground plane. This charge distribution is controlled by two mechanisms—an attractive mechanism and a repulsive mechanism as discussed by Richards [6]. The attractive mechanism is between the opposite charges on the bottom side of the patch and the ground plane, which helps in keeping the charge concentration intact at the bottom of the patch. The repulsive mechanism is between the like charges on the bottom surface of the patch, which causes pushing of some charges from the bottom, to the top of the patch. As a result of this charge movement, currents flow at the top and bottom surface of the patch. The cavity model assumes that the height to width ratio (i.e. height of substrate and width of the patch) is very small and as a result of this the attractive mechanism dominates and causes most of the charge concentration and the current to be below the patch surface. Much less current would flow on the top surface of the patch and as the height to width ratio further decreases, the current on the top surface of the patch would be almost equal to zero, which would not allow

the creation of any tangential magnetic field components to the patch edges. Hence, the four sidewalls could be modeled as perfectly magnetic conducting surfaces. This implies that the magnetic fields and the electric field distribution beneath the patch would not be disturbed. However, in practice, a finite width to height ratio would be there and this would not make the tangential magnetic fields to be completely zero, but they being very small, the side walls could be approximated to be perfectly magnetic conducting [5].

Since the walls of the cavity, as well as the material within it are lossless, the cavity would not radiate and its input impedance would be purely reactive. Hence, in order to account for radiation and a loss mechanism, one must introduce a radiation resistance R_r and a loss resistance R_l . A lossy cavity would now represent an antenna and the loss is taken into account by the effective loss tangent δ_{eff} which is given as:

$$\delta_{eff} = 1/Q_T \tag{3.7}$$

Q_T is the total antenna quality factor and has been expressed by [4] in the form:

$$\frac{1}{Q_T} = \frac{1}{Q_d} + \frac{1}{Q_c} + \frac{1}{Q_r} \tag{3.8}$$

- Q_d represents the quality factor of the dielectric and is given as:

$$Q_d = \frac{\omega_r W_T}{P_d} = \frac{1}{\tan \delta} \tag{3.9}$$

Where, ω_r is the angular resonant frequency. W_T is the total energy stored in the patch at resonance. P_d is the dielectric loss.

$\tan \delta$ is the loss tangent of the dielectric.

- Q_c represents the quality factor of the conductor and is given as:

$$Q_c = \frac{\omega_r W_T}{P_c} = \frac{h}{\Delta} \tag{3.10}$$

Where, P_c is the conductor loss. Δ is the skin depth of the conductor. h is the height of the substrate.

- Q_r represents the quality factor for radiation and is given as:

$$Q_r = \frac{\omega_r W_T}{P_r} \tag{3.11}$$

Where P_r is the power radiated from the patch. Substituting equations (3.8), (3.9), (3.10) and (3.11) in equation (3.7), we get

$$\delta_{eff} = \tan \delta + \frac{\Delta}{h} + \frac{P_r}{\omega_r W_T} \tag{3.12}$$

Thus, (3.12) describes the total effective loss tangent for the microstrip patch antenna.

IV. PATCH ANTENNA AND SIMULATION RESULTS

4.1 design specifications

Dielectric constant of substrate (ϵ_r) = 4.6

Height of substrate (h) = 1.6mm

Frequency of Operation (f_0) = 2.5 GHz

c = velocity of light = 3×10^8 m/s or = 3×10^{11} mm/s

So, for a Square patch Antenna the Length and Width is taken as 28mm.

Width (W) = Length (L) = 28mm

Depth of the slot for inset feed is given by $Y_0 = 10$ mm

4.2 Design procedure

4.2.1 Design specifications

The three essential parameters for the design of a Microstrip Patch Antenna are:

Frequency of operation (f_0): The resonant frequency of the antenna must be selected appropriately. The resonant frequency selected for my design is 2.5 GHz.

Dielectric constant of the substrate (ϵ_r): The dielectric material selected for my design is glass (FR4) which has a dielectric constant of 4.6. A substrate of a high dielectric constant when selected reduces the dimensions of the antenna.

Height of dielectric substrate (h): For the microstrip patch antenna to be used in cellular phones, it is essential that the antenna is not bulky. Hence, the height of the dielectric substrate is selected as 1.6 mm.

4.2.2 Design steps

Step 1: Calculation of the Width (W):

The width of the Microstrip patch antenna is given by the equation

$$W = \frac{C}{2f_0 \sqrt{\frac{\epsilon_r + 1}{2}}}$$

Step 2: Calculation of Effective dielectric constant (ϵ_{eff})

The effective dielectric constant is given by the equation

$$\epsilon_{eff} = \frac{\epsilon_r + 1}{2} + \frac{\epsilon_r - 1}{2} \left[\frac{1}{1 + 12 \frac{h}{W}} \right]^2$$

Step 3: Calculation of the Effective length (L_{eff})

The effective length is calculated by the equation

$$L = L_{eff} - 2\Delta L \quad L_{eff} = \frac{C}{2f_0 \sqrt{\epsilon_{eff}}}$$

Step 4: Calculation of the length extension (ΔL):

$$\Delta L = 0.412h \frac{(\epsilon_{eff} + 0.3) \left(\frac{W}{h} + 0.264 \right)}{(\epsilon_{eff} - 0.258) \left(\frac{W}{h} + 0.8 \right)}$$

Step 5: Calculation of actual length of patch (L):

The actual length is obtained by the equation

$$L = L_{eff} - 2\Delta L$$

Step 6: Calculation of the ground plane dimensions (L_g and W_g):

The transmission line model is applicable to infinite ground planes only. However, for practical considerations, it is essential to have a finite ground plane. It has been shown that similar results for finite and infinite ground plane can be

obtained if the size of the ground plane is greater than the patch dimensions by approximately six times the substrate thickness all around the periphery. Hence, for this design, the ground plane dimensions would be given as:

$$L_g = 6h + L$$

$$W_g = 6h + W$$

Specification

Frequency	: 2.5GHz
Return Loss	: >20dB
Gain	: >6 dB
VSWR	: 1:1.3
ϵ_r	: 4.6
Thickness	: 1.6mm

V. SIMULATION RESULTS

Microstrip Patch Antenna without EBG Structure For 2.5 Ghz

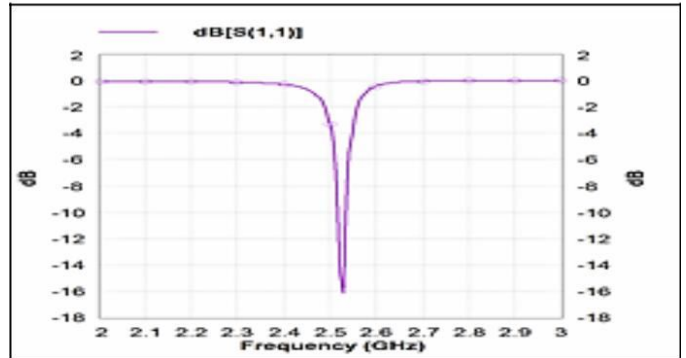
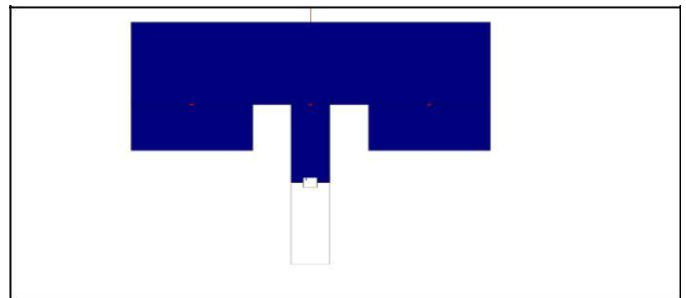

Microstrip Patch Antenna with a Single EBG Structure for 2.5 Ghz

An electronic bandgap has been made at the following specified location:

X = 0 mm; Y = 7 mm:
Radius = 1mm.

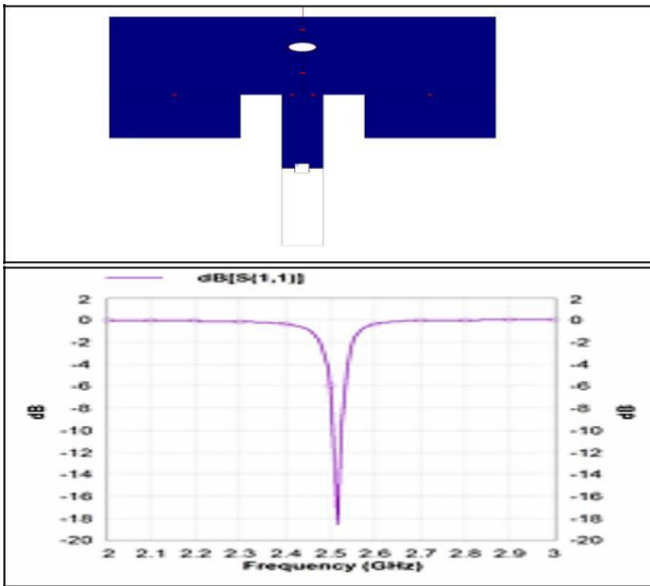

Microstrip Patch Antenna with a Three Different EBG Structure for 2.5 GHz

An electronic bandgap has been made at the following specified location:

X = -7.5 mm; X = 0 mm; X = 7.5 mm Y = 5 mm; Y = 7 mm; Y = 5 mm;

Radius=1.5mm Radius=1mm. Radius= 1.2mm.

X = -7.5 mm; X = 0 mm; X = 7.5
 Y = 5 mm; Y = 7 mm; Y = 5 mm;
 Radius = 1mm Radius = 1mm. Radius = 1mm.

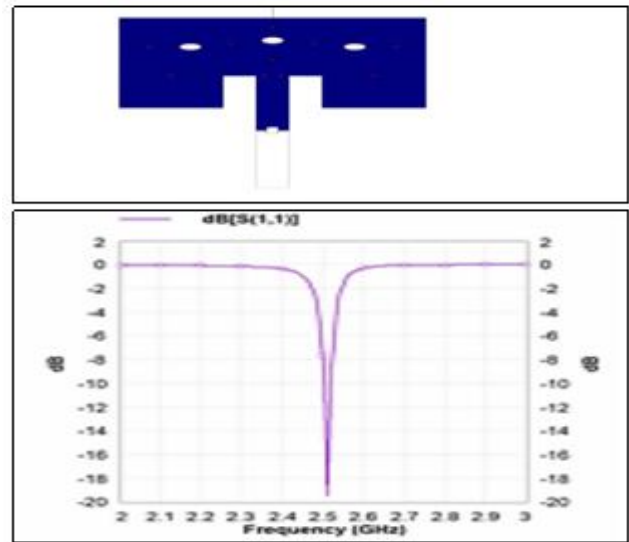

Microstrip Patch Antenna with a Five Similar EBG Structure for 2.5 GHz

An electronic bandgap has been made at the following specified location:

X = -7.5 mm; X = -8.5 mm; X = 0 mm; X = 8.5 mm; X = 7.5 mm;

Y = 5 mm; Y = 9 mm; Y = 7 mm; Y = 9 mm; Y = 5 mm; Radius = 1mm, Radius = 1mm., Radius = 1mm., Radius = 1mm, Radius = 1mm

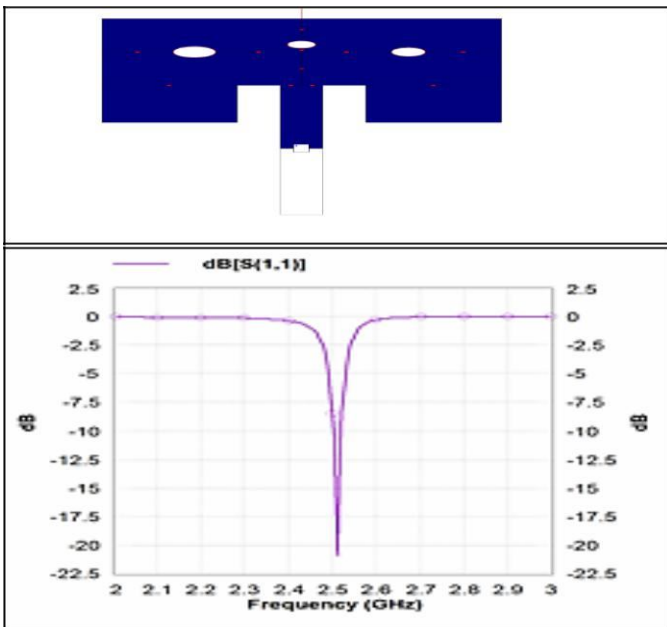

Microstrip Patch Antenna with a Three Different EBG Structure for 2.5 GHz

An electronic bandgap has been made at the following specified location:

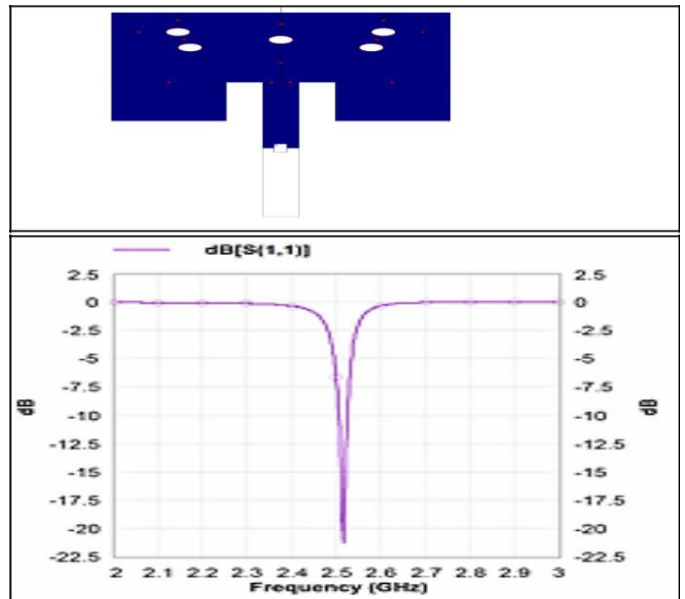

Microstrip Patch Antenna with a Single EBG Structure for 2.5 Ghz

An electronic bandgap has been made at the following specified location:

$$X = 0 \text{ mm}; Y = 7 \text{ mm}; \text{Radius} = 2\text{mm}.$$

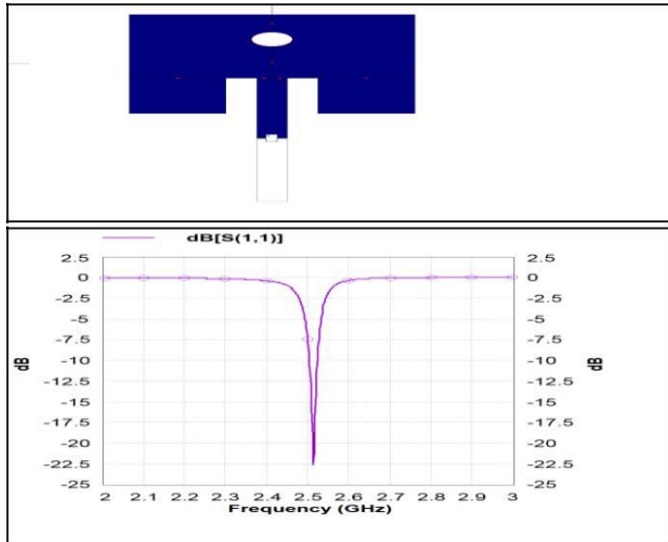

Radiation pattern and antenna parameters for 2.5 ghz

Parameter	No EBG	single EBG	three different EBG	five similar EBG
Return loss (dB)	-16.14	-18.59	-20.91	-21.23
VSWR	1.369	1.267	1.198	1.19
Radiation Efficiency (%)	87.5532	87.4144	86.9969	86.88
Antenna Efficiency (%)	47.1761	65.372	74.7341	78.07
3 dB Beamwidth (deg)	(84.123, 6,159.216)	(83.9628, 9.254)	(83.870, 4,159.328)	(83.895, 6,159.266)
Gain (dBi)	3.04752	4.46892	5.05077	5.6071
Directivity (dBi)	6.3103	6.315	6.31558	6.31673

CONCLUSION

A typical cellular phone measures about 14.5 cm by 4.5 cm. Hence the antenna designed must be able to fit in such a cellular phone. As demonstrated by the design and the results obtained in chapter 4, a compact microstrip patch antenna has been successfully designed having a center frequency of 2.5 GHz. The ground plane dimensions for the patch antenna have been designed to be 28 mm by 28 mm and

the patch dimensions are 28 mm by 28 mm. Hence the designed antenna is compact enough to be placed in a typical cellular phone. Radiation pattern plots have been obtained for the desired antenna orientation. Reduced back lobe radiation was obtained which is an added advantage for the application of the antenna in cellular handsets since this minimizes the amount of electromagnetic energy radiated towards the users head. A gain of 5.6071 dBi and directivity of 6.31673 dBi were obtained.

Another area for future work is to extend this concept to a multiband design. It is envisioned in the future, that a single handset would serve a number of applications. When the user would be at home, the handset would operate in the same frequency range as used by cordless phones and thus would be connected to the local telephone exchange. When the user would be outside his house, the handset would connect to the cellular network. On a business trip away from home, the handset would then connect through the satellite network to provide service to the user. These different networks would require that the antenna in the handset is able to operate at separate frequencies. The antenna designed in this work is a uniband antenna centered at 2.5 GHz. Work must be done to design a dichroic or trichroic microstrip patch antenna which can operate at two or three frequencies to serve multiple applications.

REFERENCES

- [1] R.B. Waterhouse (2002), Microstrip patch antennas, in Handbook of Antennas in Wireless Communications, L.C. Godara, Ed. Boca Raton: CRC Press.
- [2] W. Stutzman, G. Thiele (1998), Antenna Theory and Design, New York, John Wiley & Sons, Inc.
- [3] R. Garg, P. Bhartia, I. Bahl (2002), A. Ittipiboon, Microstrip Antenna Design Handbook, Massachusetts, Artech House, Inc.
- [4] I. Bahl, P. Bhartia, Microstrip (1980), Antennas, Massachusetts, Artech House, Inc.
- [5] Pekka Salonen, Fan Yang, Yahya Rahmat-sii, Markku Kivikoski (2002), WEBGA – Wearable Electromagnetic Band-Gap Antenna, IEEE Antennas and Wireless Propagation, pp.451-454.
- [6] He, W., Jin, R., Geng, J (2008), E-Shape patch with wideband and circular polarization for millimeter-wave communication, IEEE Transactions on Antennas and Propagation 56(3),893–895.

- [7] Lau, K.L., Luk, K.M., Lee (2006), Design of a circularly-polarized vertical patch antenna, IEEE Transactions on Antennas and Propagation, 54(4), 1332–1335.
- [8] Zhang, Y.P., Wang, J.J (2006), Theory and analysis of differentially-driven microstrip antennas, IEEE Transactions on Antennas and Propagation, 54(4), 1092–1099.
- [9] Shobhit Patel, Jaymin Bhalani, Yogesh Kosta and Sanket Patel (2011), Design of Microstrip Meandered Patch Antenna for Mobile Communication, pp. 184–189, Springer-Verlag Berlin Heidelberg.