

# Fault Current Mitigation And Elimination In High Voltage Transmission Line With PSB, OST And FCL Unit

Dipak Raman Joshi<sup>1</sup>, Saurabh H. Thakare<sup>2</sup>, Yogesh P. Sushir<sup>3</sup>

<sup>1, 2, 3</sup>Dept of Electrical Engineering

<sup>1, 2, 3</sup>Padm. Dr. VBKCOE

**Abstract-** Contingency analysis of any grid involves finding out the behavior of the ability System once applying to disturbance or any abnormalcy. This project involves the study of ways to find Power Swing on a line and verification of ways to find Power Swing supported rate of amendment in electrical resistance. Here, package is needed for such analysis as a result of in sensible cases networks area unit terribly difficult and for an equivalent system, modeling the complete element in line with real system facilitates easier approach to check an equivalent network while not imposing it to sensible condition. therefore to keep up system stability such contingency analysis plays very important role. a 3 space grid model is meant in SIMULINK package and simulated information is employed for analysis during this paper. electrical resistance seen by Distance Relay enters zone that is about usually ninetieth of line electrical resistance inside one-cycle and it'll be virtually stable at electrical resistance adequate fault electrical resistance seen by relay. Whereas just in case of Power Swing electrical resistance changes slowly and takes old to enter zone settings. So, exploitation this technique, we are able to find Fault inside one -cycle. If electrical resistance is ever-changing slowly, we are able to block relay from operation.

**Keywords-** Contingency, Relay, Power Swing, Faults, Distance Relay.

## I. INTRODUCTION

Steady state power systems generally operate near their rated frequency. A balance between active and reactive power generated and consumed exists under stationary operating conditions, and the transmit and receive voltage differences are typically less than 5%. System frequency on a large power system typically varies within +/- 0.02Hz on a 50Hz power system. Power system failures, line switching, generator disconnection and failure. Loss or the application of large blocks of load cause sudden changes in electrical power, while the mechanical power input to the generators remains relatively constant. These system disturbances cause

oscillations in the corners of the machine rotor and can cause large oscillations in the power flow. Depending on the severity of the disturbance and the actions of the electrical system controls, the system may remain stable and return to a new state of equilibrium by experiencing what is called a stable power swing. Severe system disturbances, on the other hand, could cause large separation of generator rotor angles, large fluctuations in power flow, large fluctuations in voltages and currents, and loss of synchronism between generator groups or between neighboring utility systems. Large, stable, or unstable power fluctuations can cause unwanted relay operations on networks at different locations, which can further exacerbate power system disturbances and eventually lead to cascading blackouts and blackouts. In this project we will use the FCL unit with PSB and OST so that we can limit the fault current.

## II. CONCLUSION OF PREVIOUS WORK

Above simulation results validate that the methods i.e. Change of positive sequence impedance is useful for detection of power swing. But it has to have protective equipments which can response faster in order to response quickly to detect it. This analysis is useful to enable the power system blocking (PSB) setting of relays. Power swings both stable and unstable can precipitate wide spread outages to power systems with the result that cascade tripping of the power system elements occur. Protection of power systems against the effects of power swings both stable and unstable has been described in this thesis. The thesis has given an overview of power swings, their causes and detection. Methods of detecting and protecting the power system against power swings have been discussed and elaborated. Detailed system studies both steady state and transient are required to determine the application of power swing protection. Extensive stability studies under different operating conditions must be performed to determine the rate of change of power swings. Protective relays use a number of methods to detect the presence of a power swing, the most common being the change of the positive sequence impedance. Other power System quantities have also been used for power-swing

detection such as power and its rate of change, the phase angle difference across a transmission line or path and its rate of change.

### III. OBJECTIVE OF THE WORK

1. Primary objective of proposed system to protect the transmission line from three phase fault.
2. To design OST circuit for separation of circuit after fault.
3. To design FCL unit limit the fault current to lower value
4. Simulate and compare overall circuit with FCL and Without FCL.

### IV. POWER SWING DETECTION METHOD

#### A. Continuous Impedance Calculation Method

This technique determines an influence swing condition supported a continual electric resistance calculation as shown in fig 3.1. Continuous here means, for example, that for every five ms step associate degree impedance calculation is performed and compared with the impedance calculation of the previous 5 ms. As before long as there's a deviation, an out-of-step scenario is assumed however not verified yet. subsequent impedance that In ternational Journal of research in Science, Engineering and Technology (ijsrset.com) 108 ought to be calculated 5 ms later is foretold based on the impedance difference of the previous measured impedances.

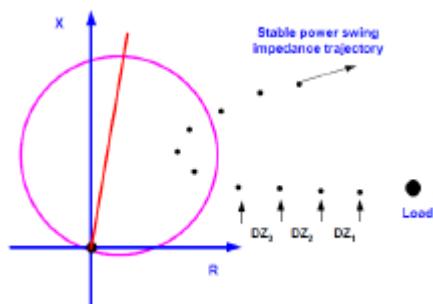

Figure 1. Power swing detection with continuous impedance calculation

#### B. Rate of Change of Impedance PSB and OST Methods

Conventional Power Swing Blocking schemes are depends on measuring the positive-sequence impedance at a relay. Under normal operating conditions, the measured impedance is the load impedance, and its locus is away from the distance relay protection characteristics. When a fault take place, the measured impedance moves rightaway from the loa d impedance location to the location that show the fault on the impedance plane. Under a system fault, the rate of impedance change seen by the relay is defined by the amount of signal

filtering in the Relay. Under a system swing, the measured impedance moves slowly on the impedance plane, and the rate of impedance change is defined by the slip frequency of an equivalent two-source system. Conventional Power Swing Blocking schemes use the difference between impedance rate of change during a fault and during a power swing to differentiate between a fault and a swing. To differentiate, one typically places two concentric impedance characteristics, separated by impedance  $\Delta Z$ , on the impedance plane and uses a time to time the duration of the impedance locus as it travels between them. If the measured impedance cross the concentric characteristics before the timer expires, the relay declares the event a system fault. Otherwise, if the timer expires before the impedance crosses both impedance characteristics; the relay classifies the event as a power swing.

### V. NEED OF FCL UNIT

Power systems are very complex in nature due to the integration of several power electronic devices. Protection of this power systems and reliability as well as stability are depend on limiting the fault currents. Some fault current limiters (FCLs) have been applied in power systems as they provide rapid and efficient fault current limitation

### VI. SIMULATION RESULT

The above is modeling of considered test system with two networks on sending end side and receiving end side with same rating sources.your paper.

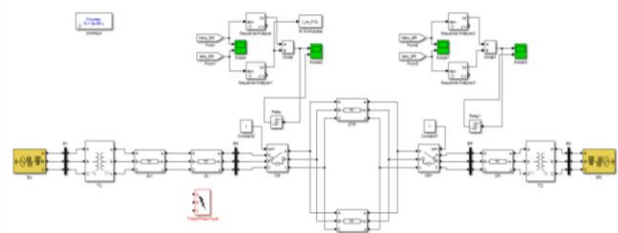

Figure2. Test system modeling with two networks

The simulation is run for 1sec with not fault or OST connected to the networks and the results are shown below.

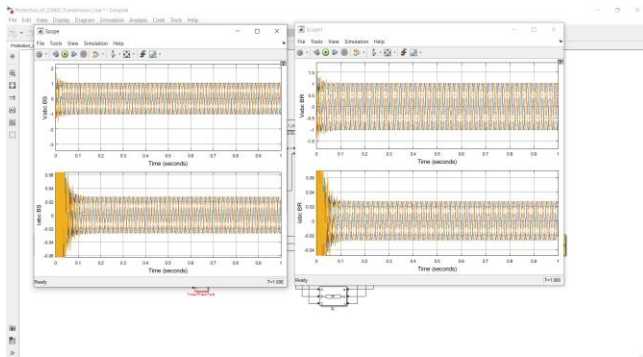

Figure 3. Three phase voltages and currents of two networks on sending end and receiving end

The above are the three phase voltages and currents of the two networks during no fault and no OST conditions. The below are the impedances of the two networks during no fault condition.

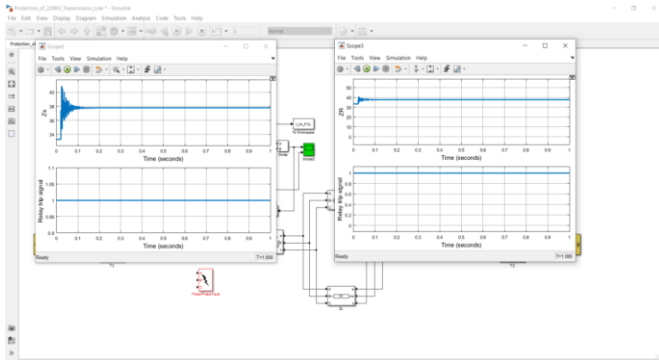

Figure 4. Impedance measurement of the two networks

The same network is connected with three phase to ground fault on the sending end side. The system is not connected with OST and the simulation results are shown below. The below are the three phase voltages and currents of the two networks during three phase to ground fault from 0.5-0.6sec with no OST module.

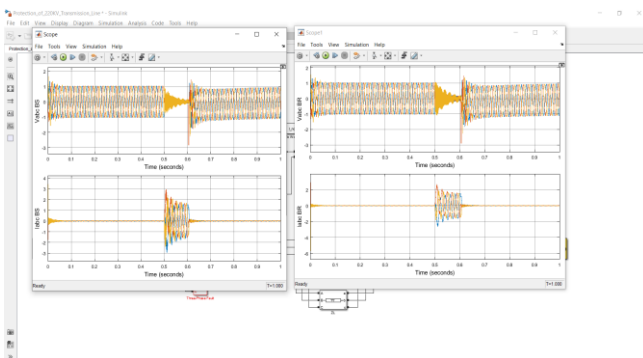

Figure 5. Three phase voltages and current during three phase to ground fault without OST

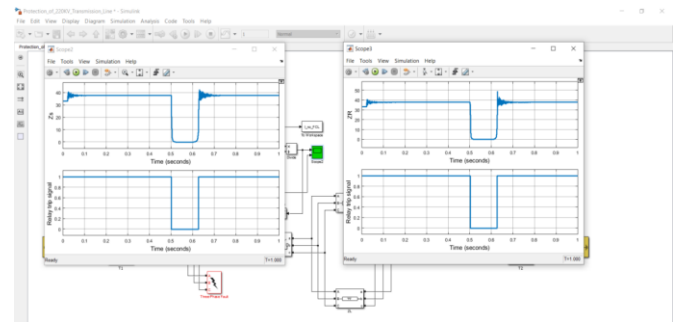

Figure 6. Impedance and relay tripping signal of two networks without OST

The same simulation model is updated with OST where the circuit breakers are operated with impedance relay on the sending end side and receiving end side. The three phase voltages and currents during three phase to ground fault are shown for the same with OST on both sides of the network.

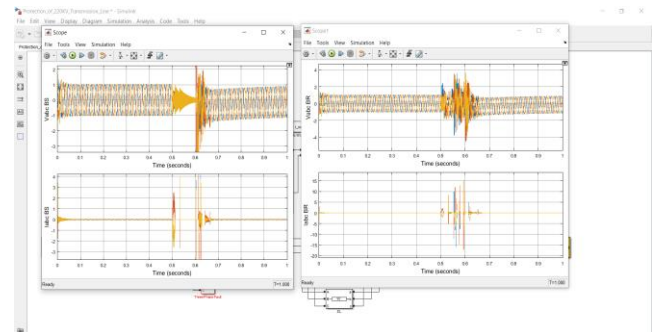

Figure 7. Three phase voltages and current during three phase to ground fault with OST

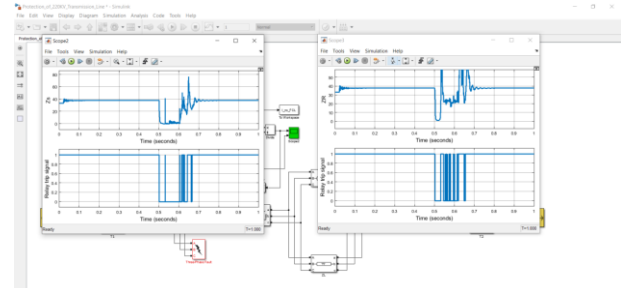

Figure 8. Impedance and relay tripping signal of two networks with OST

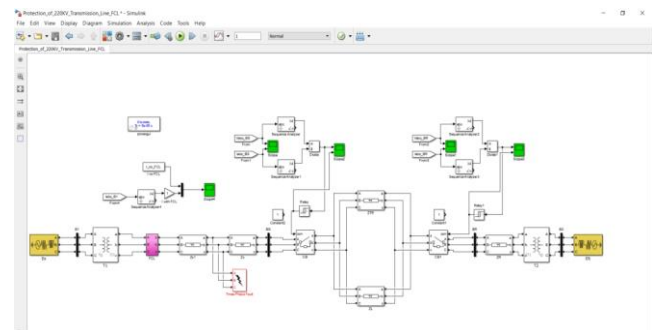

Figure 9. Test system with FCL connected on the fault side network

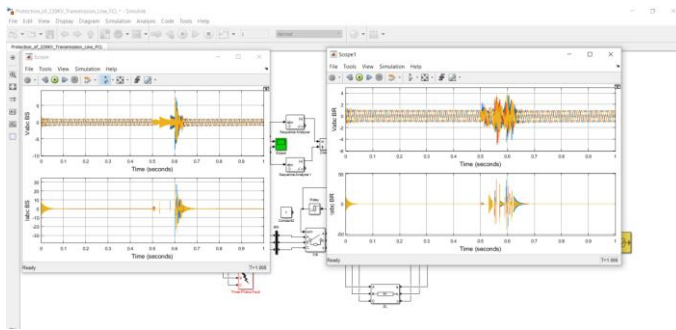

Figure 10. Three phase voltages and current during three phase to ground fault with OST and FCL

The above are the three phase voltages and currents when the test system is run with FCL unit on the sending end side. And below are the impedances of the two networks with FCL unit during three phase to ground fault condition.

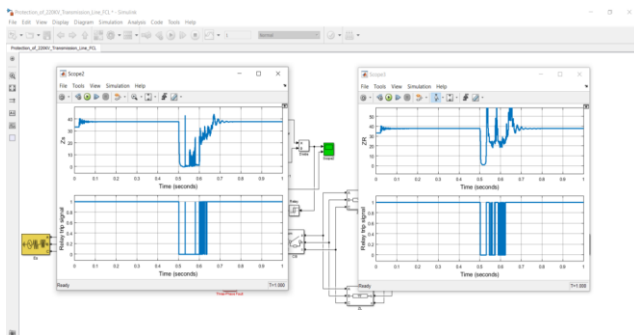

Figure 11. Impedance and relay tripping signal of two networks with OST and FCL

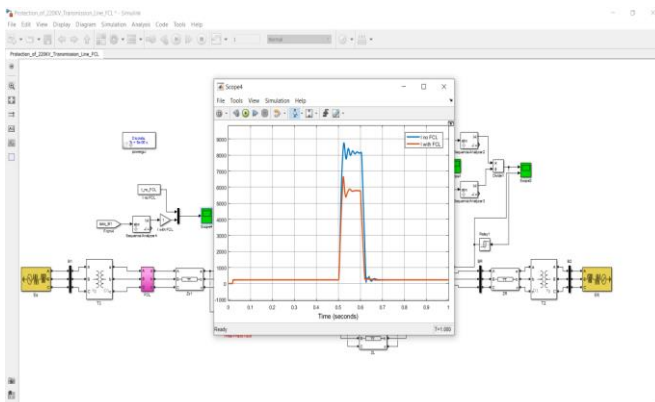

Figure 12. Comparison of fault current during fault with and without FCL on the sending end network

The above is the fault current comparison on sending side network with and without FCL unit connected in series to the network. As compared the current with FCL unit is less as compared to no FCL unit.

## VII. CONCLUSION

Protection of transmission line done using OST and FCL unit overall system done with total four part

1. Simulate and observed the system with PSB and no fault condition.
2. Simulate and observed the system with PSB and fault condition.
3. Simulate and observed the system with PSB, OST and fault condition.
4. Simulate and observed the system with PSB, OST, FCL and fault condition
  - It is observed that using OST phenomenon the protection of transmission line on occurrence of fault can be done also
  - Also comparative of with and without FCL done using FCL fault current limit to lower value observed.

## REFERENCES

- [1] Majid Sanaye-Pasand and Ali NaderianJahromi , "Study, Comparison and Simulation of Power System Swing Detection and Prediction Methods", 0-7803-7989-6/03/\$17.00 02003 IEEE
- [2] Xiangning Lin, Yan Gao, and Pei Liu, "A Novel Scheme to Identify Symmetrical Faults Occurring During Power Swings". IEEE Trans. On Power Delivery, vol. 23, no. 1, January 2007.
- [3] Edith Clarke, "Impedance Seen by Relay during Power Swing With and Without Faults", AIEE Trans., pp.372-384.
- [4] A. R. Van C. Warrington, "Graphical Method for Estimating the Performance of Distance Relays during Faults and Power Swings," AIEE Trans.vol. 68 (1949), pp. 660-672.
- [5] Liancheng Wang and Adly A. Girgis, "A New Method for Power System Transient Instability Detection", IEEE Transactions on Power Delivery, Vol. 12, No. 3, pp.1082-1089 , July 1997.
- [6] J. Blumschein, Y. Yelgin, and M. Kereit, "Proper detection and treatment of power swing To reduce the risk of Blackouts", DRPT2008 6-9 April 2008 Nanjing Chin,pp.2440-2446.
- [7] Dali Wu, XianggenYin ,Zhe Zhang, and Kanjun Zhang, "Research on Improved Fault Classification Scheme during Power Swing", UPEC 2007,pp. 296-299.
- [8] Hiroyuki Amano, Teruhisa Kumano, and Toshio Inoue, "Nonlinear Stability Indexes of Power Swing Oscillation Using Normal Form Analysis", IEEE Trans. On Power Systems, Vol. 21, No.2, pp. 825-833, May 2006 .

- [9] Rudra Pratap, "MATLAB -7",Oxford University, 0195179374 RG
- [10]GEK-113248 D90Plus Instruction Manual, revision1.8x  
Copyright © 2010 GE Multilin 215 Anderson Avenue,  
Markham, Ontario Canada L6E 1B3
- [11]SEL-421-4-5 Relay Instruction Manual Date Code  
20101221. © 2010 by Schweitzer Engineering  
Laboratories, Inc.
- [12]1MRK506312-  
UEN\_A\_en\_Technical\_reference\_manual\_\_REL670\_1.2  
© Copyright 2011 ABB
- [13]E. W. Kimbark, Power System Stability, vol. 2, John  
Wiley and Sons, Inc., New York, 1950
- [14]C37.233-2009 IEEE Guide for Power System Protection  
Testing