

Active Shunt Power filter using PI Controller for Power Quality Improvement

Dodiya Siraj Ahemad G.¹, Nadar Thangamalar N.², Patel Jignesh V.³, Patel Darshan R.⁴

^{1,3} SCET. Saij, Kalol

² Faculty of Engg. SCET, Rajpur

⁴ ACET. khatraj, Gandhinagar

Abstract- In This paper we use PI controller for improve the power quality using shunt active power filter. And PWM pattern generation is based on carrier less hysteresis based current control to obtain the switching signals to the voltage sourced PWM converter. Make a simulation of shunt active power filter in MATLAB.

I. INTRODUCTION

The application of power electronics devices such as arc furnaces, adjustable speed drives, Computer power supplies etc. are some typical non-linear characteristic loads used in most of the industrial applications and are increasing rapidly due to technical improvements of semiconductor devices, digital controller and flexibility in controlling the power usage. The use of the above power electronic devices in power distribution system gives rise to harmonics and reactive power disturbances.

The harmonics and reactive power cause a number of undesirable effects like heating, equipment damage and Electromagnetic Interference effects in the power system. The conventional method to mitigate the harmonics and reactive power compensation is by using passive LC filters but this method has drawbacks like large size, resonance problem and fixed compensation behavior.

The solution of these problem is the active power filter (APF) comes in to the picture, which gives promising solution to compensate for the above adverse effects of harmonics and reactive power simultaneously by using suitable control algorithms.

This report contains issues related with electrical system about power quality and available solutions to mitigate those issues.

II. POWER QUALITY ISSUE

The PQ issue is defined as “any occurrence manifested in voltage, current, or frequency deviations that results in damage, upset, failure, or misperation of end-use

equipment.” Almost all PQ issues are closely related with PE in almost every aspect of commercial, domestic, and industrial application. Equipment using power electronic device are residential appliances like TVs, PCs etc. business and office equipment like copiers, printers etc. industrial equipment like programmable logic controllers (PLCs), adjustable speed drives (ASDs), rectifiers, inverters, CNC tools and so on [5]. The Power Quality (PQ) problem can be detected from one of the following several symptoms depending on the type of issue involved.

- Lamp flicker
- Frequent blackouts
- Sensitive-equipment frequent dropouts
- Voltage to ground in unexpected
- Locations
- Communications interference
- Overheated elements and equipment

III. SOLUTION OF POWER QUALITY PROBLEM

There are two approaches to the mitigation of power quality problems. The first approach is called load conditioning, which ensures that the equipment is made less sensitive to power disturbances, allowing the operation even under significant voltage distortion. The other solution is to install line-conditioning systems that suppress or counteract the power system disturbances. Passive filters have been most commonly used to limit the flow of harmonic currents in distribution systems. They are usually custom designed for the application. However, their performance is limited to a few harmonics, and they can introduce resonance in the power system. Among the different new technical options available to improve power quality, active power filters have proved to be an important and flexible alternative to compensate for current and voltage disturbances in power distribution systems. The idea of active filters is relatively old, but their practical development was made possible with the new improvements in power electronics and microcomputer control strategies as well as with cost reduction in electronic components. Active power filters are becoming a viable alternative to passive filters and are gaining market share speedily as their cost becomes competitive with the passive

variety. Through power electronics, the active filter introduces current or voltage components, which cancel the harmonic components of the nonlinear loads or supply lines, respectively. Different active power filters topologies have been introduced and many of them are already available in the market.

IV. POWER FILTER TOPOLOGIES

Depending on the particular application or electrical problem to be solved, active power filters can be implemented as shunt type, series type, or a combination of shunt and series active filters (shunt-series type). These filters can also be combined with passive filters to create hybrid power filters [3].

The shunt-connected active power filter, with a self-controlled dc bus, has a topology similar to that of a static compensator (STATCOM) used for reactive power compensation in power transmission systems. Shunt active power filters compensate load current harmonics by injecting equal-but opposite harmonic compensating current. In this case the shunt active power filter operates as a current source injecting the harmonic components generated by the load but phase-shifted by 180° [2].

Series active power filters were introduced by the end of the 1980s and operate mainly as a voltage regulator and as a harmonic isolator between the nonlinear load and the utility system. The series-connected filter protects the consumer from an inadequate supply-voltage quality. This type of approach is especially recommended for compensation of voltage unbalances and voltage sags from the ac supply and for low-power applications and represents an economically attractive alternative to UPS, since no energy storage (battery) is necessary and the overall rating of the components is smaller. The series active filter injects a voltage component in series with the supply voltage and therefore can be regarded as a controlled voltage source, compensating voltage sags and swells on the load side. In many cases, series active filters work as hybrid topologies with passive LC filters. If passive LC filters are connected in parallel to the load, the series active power filter operates as a harmonic isolator, forcing the load current harmonics to circulate mainly through the passive filter rather than the power distribution system. The main advantage of this scheme is that the rated power of the series active filter is a small fraction of the load kVA rating, typically 5%. However, the apparent power rating of the series active power filter may increase in case of voltage compensation [1].

V. BASIC COMPENSATION PRINCIPLE OF SHUNT ACTIVE POWER FILTER

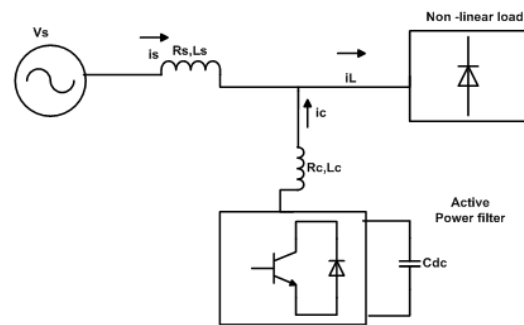

Fig 1. Shunt active power filters Basic compensation principle

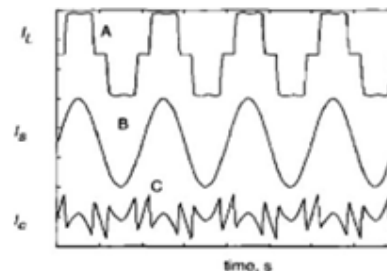

Figure 2 Shunt active power filter-Shapes of load, source and desired filter current wave forms

Figure 1 shows the basic compensation principle of a shunt active power filter. It is controlled to draw / supply a compensating current i_c from / to the utility, so that it cancels current harmonics on the AC side, and makes the source current in phase with the source voltage. Figure.2. shows the different waveforms. Curve A is the load current waveform and curve B is the desired mains current. Curve C shows the compensating current injected by the active filter containing all the harmonics, to make mains current sinusoidal [6].

VI. PI CONTROL SCHEME

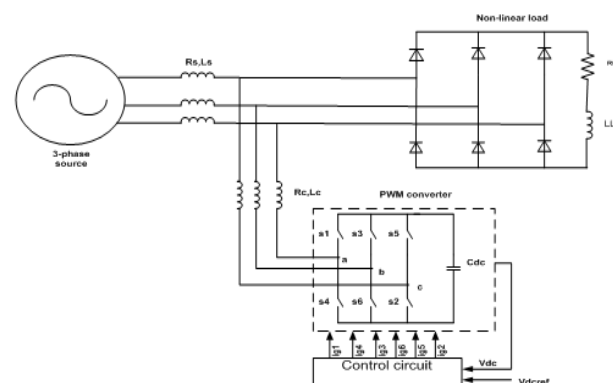

Figure 3. Schematic diagram of shunt active filter.

The complete schematic diagram of the shunt active power filter is shown in figure 3 gives the control scheme realization. The actual capacitor voltage is compared with a set reference value.

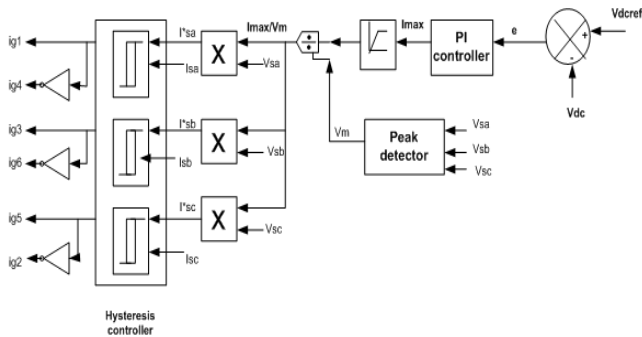

Figure 4. APF Control Scheme with PI Controller

The error signal is fed to PI controller. The output of PI controller has been considered as peak value of the reference current. It is further multiplied by the unit sine vectors (u_{sa} , u_{sb} , and u_{sc}) in phase with the source voltages to obtain the reference currents (i_{sa}^* , i_{sb}^* , and i_{sc}^*). These reference currents and actual currents are given to a hysteresis based, carrier less PWM current controller to generate switching signals of the PWM converter [2]. The difference of reference current template and actual current decides the operation of switches. To increase current of particular phase, the lower switch of the PWM converter of that particular phase is switched on, while to decrease the current the upper switch of the particular phase is switched on. These switching signals after proper isolation and amplification are given to the switching devices. Due to these switching actions current flows through the filter inductor L_c , to compensate the Harmonic current and reactive power of the load, so that only active power drawn from the source.

VII. SIMULATION SYSTEM PARAMETERS

Table 1 Simulation Parameter

System Parameters	Values
Source voltage(V_s)	415(peak)
System frequency(f)	50Hz
Source impedance(L_s)	0.15mH
Filter impedance(R_c, L_c)	0.4 Ω ,3mH
Load impedance(R_l, L_l)	6.7 Ω ,20mH
DC link capacitance	2000 μ F
Reference DC link voltage(V_{dcref})	600V

VIII. RESULT

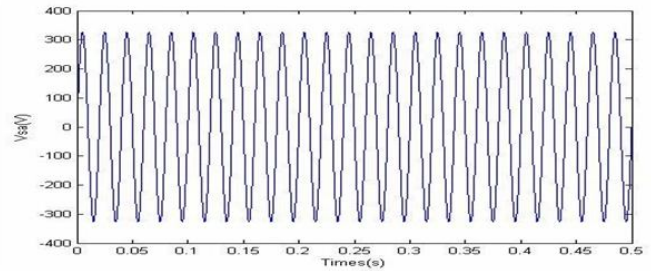

Figure 5 source voltage

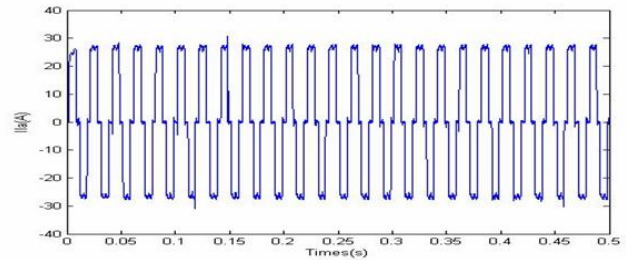

Figure 6 line current

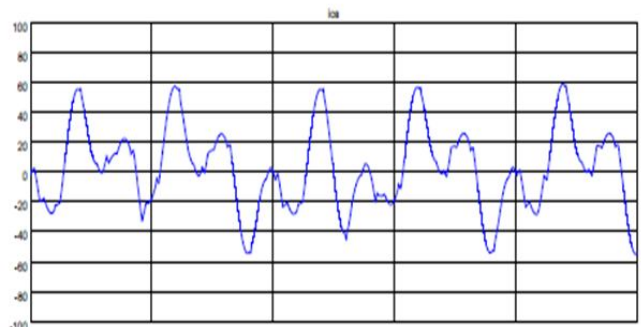

Figure 7 compensating current using pi controller

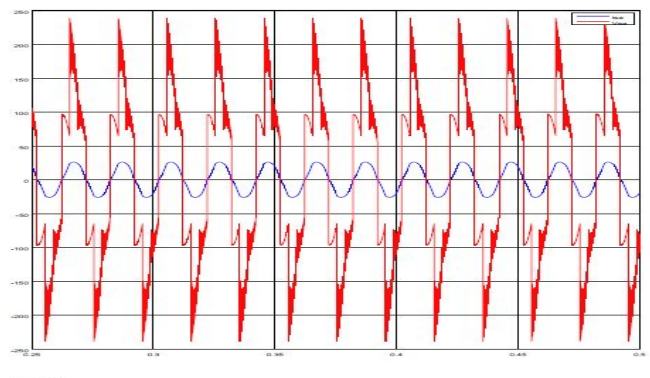

Figure 8 voltage and current in phase with pi controller after compensation

IX. CONCLUSION

This paper has presented a simulation study of PI based hysteresis current controlled active shunt power filter for harmonic and reactive power compensation of the non –

linear load. Using PI controller the source current THD is reduce 28% to 2.2%.PI controller based shunt active power filter in MATLAB. It is found from simulation results that shunt active power filter improves power quality of the power system by eliminating harmonics and reactive current of the load current, which makes the load current sinusoidal and in phase with the source voltage.

REFERENCES

- [1] W. M. Grady, M. J. Samotyj, and A. H. Noyola, "Survey of active power line conditioning methodologies," *IEEE Transactions on Power Delivery*, vol. 5, no. 3, Jul. 1990, pp. 1536–1542.
- [2] S. Jain, P. Agarwal, and H. O. Gupta, "Design simulation and experimental investigations on a shunt active power filter for harmonics and reactive power compensation," *Electrical Power Components and Systems*, vol. 32, no. 7, Jul. 2003, pp. 671 –692.
- [3] F. Z. Peng, H. Akagi, and A. Nabae, "Study of active power filters using quad series voltage source PWM converters for harmonic compensation," *IEEE Transactions on Power Electronics*, vol. 5, no. 1, Jan. 1990, pp. 9 –15.
- [4] H.Akagi, "Trends in active power line conditioners," *IEEE Transactions on power Electronics*, vol 9, no 3, 1994, pp 263-268.
- [5] S. K. Jain, P. Agrawal, and H. O. Gupta, "Fuzzy logic controlled shunt active power filter for power quality improvement," *Proceedings of Institute of Electrical Engineers, Electrical Power Applications*, vol. 149, no. 5, 2002.
- [6] L.A.Morgan, J.W.Dixon & R.R.Wallace, "A three phase active power filter operating with fixed switching frequency for reactive power and current harmonics compensation," *IEEE Transactions on Industrial Electronics*, vol.42, no.4, August 1995, pp 402-408.
- [7] B. Singh, A. Chandra, and K. Al-Haddad, "Computer-aided modeling and simulation of active power filters," *Electrical Machines and Power Systems*, vol. 27, 1999, pp. 1227–1241.
- [8] B. Singh, A. Chandra, and K. Al-Haddad, "A review of active filters for power quality improvement," *IEEE Transactions on Industrial Electronics*, vol.46, no 5, Oct 1999, pp1-12.
- [9] R. M. Duke and S. D. Round, "The steady state performance of a controlled current active filter," *IEEE Transactions on Power Electronics*, vol. 8, Apr. 1993, pp. 140–146.
- [10] J.W.Dixon, J.J.Garcia & L.Morgan, "Control system for three phase active power filter which simultaneously compensates power factor and unbalanced loads," *IEEE Transactions on Industrial Electronics*, vol.42, no.6, 1995, pp636-641.
- [11] K. Chatterjee, B. G. Fernandes, and G. K. Dubey, "An instantaneous reactive volt-ampere compensator and harmonic suppressor system," *IEEE Transactions on Power Electronics*, vol. 14, no. 2, Mar. 1999, pp. 381–392.
- [12] D.A.Torey& A.M..Al-Zamel, "A single phase active filter for multiple nonlinear load," *IEEE Transactions on Power Electronics*, vol.10, May 1995, pp.263-272.
- [13] V.Soaes, P.Verdelho & G.D. Marques, "An instantaneous active and reactive current component method of active filter,"*IEEE Transactions on Power Electronics*, vol.15, no.4, July 2000, pp.660-669.
- [14] LEE C.C., "Fuzzy logic in control systems: fuzzy logic controller part I and II," *IEEE Trans. Syst. Man Cybern*, 1990, vol.20, pp.404-435.